

# powermaster

## D-SWI

**Industrial Swing Gate Operator with DC motor for high traffic applications. Ideal for Commercial Properties.**

### STANDARD FEATURES

- BATTERY BACKUP
- 588 WATTS (1/2 HP EQUIVALENT), 24 VDC MOTOR
- NITRO BOARD WITH 4-LINE LCD DISPLAY
- AC POWER OUTLETS
- SOFT START/SOFT STOP
- TIMER TO CLOSE
- DUAL GATE OPERATION
- EASY SET LIMITS
- LEFT/RIGHT CHANGEVER IN FIELD



*Complete selection of control stations  
& accessories are available.*

All gate operators must have contact and non-contact sensing system installed for operator to work properly and safely.

 @PowerMaster

 /PowerMasterOperators

**www.PowerMasterNY.com**  
**SERVICING THE INDUSTRY SINCE 1969**

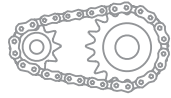

## SPECIFICATIONS & FEATURES

**MOTOR:** 588 WATTS (1/2 HP EQUIVALENT), 24 VDC

**POWER INPUT:** 115V, 1PH

**TRAVEL SPEED:** 18 SECONDS TO FULL OPEN OR FULL CLOSE

**GATE CAPACITY:** 2000 LBS, 30 FEET COMMERCIAL CAPACITY, UP TO 60 CYCLES PER HOUR

HARD SHELL, BAKED-ON, WEATHER RESISTANT POWDER COATING

HEAVY DUTY #7 GA. STEEL FRAME

NEMA 1 THREE-BUTTON CONTROL STATION INCLUDED

POWER FAIL OPERATION CAN BE SET TO OPEN GATE OR CYCLE GATE

V-BELT PRIMARY REDUCTION FOR SMOOTH, QUIET AND POSITIVE OPERATION

DRIVE ARM EASILY DISCONNECTED FOR MANUAL OPERATION IN CASE OF POWER FAILURE

PAD-MOUNTABLE FOR A STRONG, SOLID INSTALLATION

CLASS II LOW VOLTAGE CONTROL CIRCUIT

UL 325 LISTED FOR USE IN CLASS I THROUGH IV APPLICATION

**SHIPPING WEIGHT:** APPROX. 350 LBS

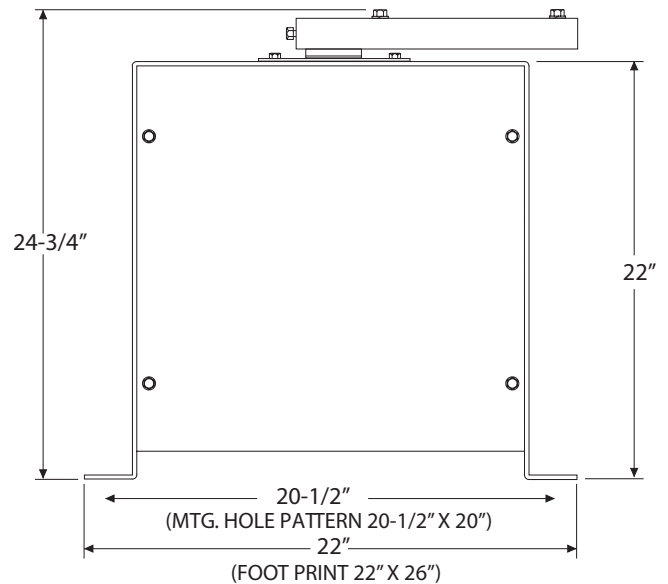

## OPTIONAL EQUIPMENT

- ADDITIONAL SAFETY EDGE (CONTACT SAFETY SENSOR)
- ADDITIONAL PHOTO CELL (NON-CONTACT SAFETY SENSOR)
- LOOP DETECTORS
- CARD KEY READER
- THERMOSTATICALLY CONTROLLED COOLING FAN FOR HOT CLIMATES
- MAGNETIC GATE LOCK
- 18" RISER



## CAUTION

A moving gate can cause serious injury or death! Carefully read and follow all safety instructions, precautions, and guidelines when installing and using this product. Motorized gates are for vehicles only. Pedestrians must use a separate entrance. **NO ONE SHOULD CROSS THE PATH OF A MOVING GATE!** Proper reversing devices must be installed on gates to avoid all hazards, pinch points and entrapment. Eliminate all hazards, pinch points and entrapment areas. Warning signs must be permanently installed and visible to traffic and pedestrians. Do not mount operating devices accessible through gates or between a gate and wall. Never allow children to lay in the path of a gate. Never allow children to operate or play with the gate controls. Follow UL 325 and ASTM F220-02 standards. Do not install this product unless all hazards, pinch points and entrapment points are protected.

