

# LiftMaster®

Gate Access Systems

## LA400 & LA400-S

### MEDIUM DUTY SWING GATE OPERATOR

#### OWNER'S MANUAL

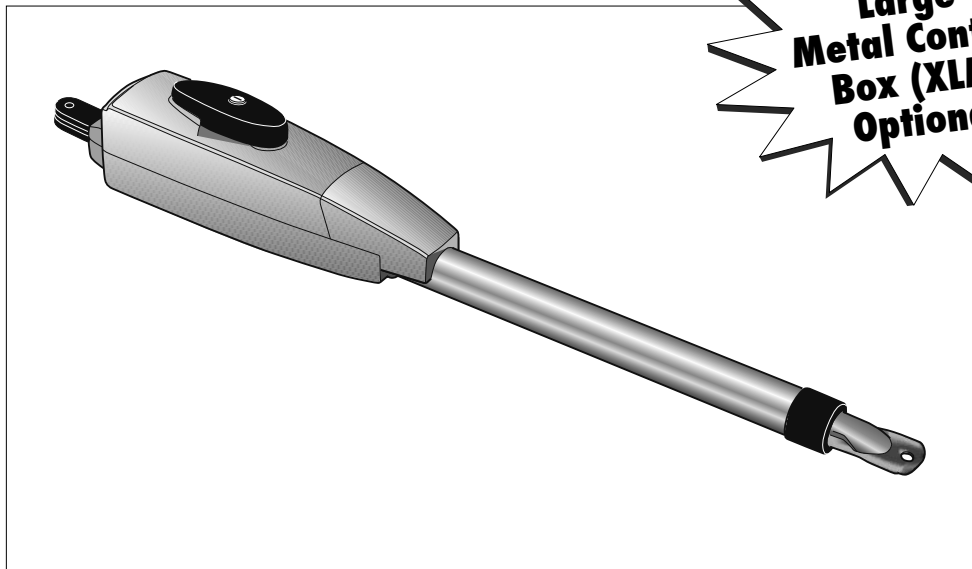

**Large  
Metal Control  
Box (XLM)  
Optional**

Serial # Primary Arm \_\_\_\_\_  
Serial # Secondary Arm \_\_\_\_\_  
Serial # Control Box \_\_\_\_\_  
Installation Date \_\_\_\_\_

The LA400 is intended for use with vehicular swing gates.

The operator can be used in Class I, Class II and Class III applications.

#### 2 YEAR WARRANTY

Radio Receiver  
Built on Board

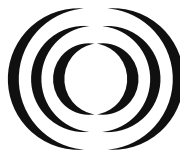

315 MHz



# TABLE OF CONTENTS

## SAFETY

Safety Symbol and Signal Word Review	
UL325 Model Classifications	
Safety Installation Information	
Gate Construction Information	
Important Safety Information	

## INTRODUCTION

Operator Specifications	
Carton Inventory	
Additional Items Needed for Installation	
Tools Needed	

## INSTALLATION

Overview of Typical Installation	
Check Your Gate	
Mounting Options	
Manual Release	
Determine Position of the Pull-to-Open Bracket	
Determine Position of the "Optional" Push-to-Open Bracket	
Assemble Gate Post Bracket (Pull-to-Open)	
Attach Brackets to Gate Operator	
Determine Mounting Location	
Measuring and Marking for the Gate Bracket	
Position Gate Operator on Gate	
Test Gate Travel	
Secure Post Bracket to Gate Post	
Secure Gate Bracket to Gate	
Warning Sign Placement	
Standard Control Box	
Large Metal Control Box (XLM)	

## WIRING

Connect the Gate Operator (Gate 1) to the Control Box	
Set the Bipart Delay (Model LA400-S Only)	
Connect the Gate Operator (Gate 2) to the Control Box (Model LA400-S Only)	
Junction Box (Model LA400-S Only)	
Connect Transformer to Control Board	
Earth Ground Rod Installation (Optional)	
Connect Batteries	

1-6	ADJUSTMENT	29-33
1	Set DIP Switch	29
2	Limits	30-32
3	Force Adjustment	33
4	Timer-to-Close	33
5-6	PROGRAMMING	34
7-8	Remote Controls	34
7	Keyless Entry	34
7	Erase All Codes	34
8	Test	34
8		
	ADDITIONAL FEATURES	35-38
9-21	DIP Switch Settings	35
9-10	Control Inputs	36
11	Loop Inputs	37
11	Photo/Edge Inputs (P6-7-8 and 9)	37
12	Safety Accessories for Secondary Entrapment Protection	38
12		
12	OPERATION AND MAINTENANCE	39-40
13	Reset Button	39
13	Remote Control	39
14	Manual Release	39
14	Maintenance	40
15	TROUBLESHOOTING	41-43
16	Basic Control Board Layout	41
16	Wiring Diagram	42
17	Diagnostic Codes	42
17	Troubleshooting Chart	43
18-19		
20-21	REPAIR PARTS	44-45
	Control Box	44
	Gate Operator Arm	44
	How to Order Repair Parts	45
22-28	WARRANTY POLICY	45
22		
23		
24		
25-26	ACCESSORIES	46
27		
28	TEMPLATE	BACK COVER
28		

## SAFETY » SAFETY SYMBOL AND SIGNAL WORD REVIEW

When you see these Safety Symbols and Signal Words on the following pages, they will alert you to the possibility of **Serious Injury or Death** if you do not comply with the warnings that accompany them. The hazard may come from something mechanical or from electric shock. Read the warnings carefully.

When you see this Signal Word on the following pages, it will alert you to the possibility of damage to your gate and/or the gate operator if you do not comply with the cautionary statements that accompany it. Read them carefully.

### IMPORTANT NOTE

- *BEFORE attempting to install, operate or maintain the operator, you must read and fully understand this manual and follow all safety instructions.*
- *DO NOT attempt repair or service of your gate operator unless you are an Authorized Service Technician.*

 **WARNING**

MECHANICAL

 **WARNING**

ELECTRICAL

**CAUTION**

# SAFETY » UL325 MODEL CLASSIFICATIONS

## CLASS I - RESIDENTIAL VEHICULAR GATE OPERATOR

A vehicular gate operator (or system) intended for use in a home of one to four single family dwellings, or a garage or parking area associated therewith.

## CLASS II - COMMERCIAL/GENERAL ACCESS VEHICULAR GATE OPERATOR

A vehicular gate operator (or system) intended for use in a commercial location or building such as a multi-family housing unit (five or more single family units) hotel, garage, retail store or other building servicing the general public.

## CLASS III - COMMERCIAL/GENERAL ACCESS VEHICULAR GATE OPERATOR

A vehicular gate operator (or system) intended for use in a industrial location or building such as a factory or loading dock area or other locations not intended to service the general public.

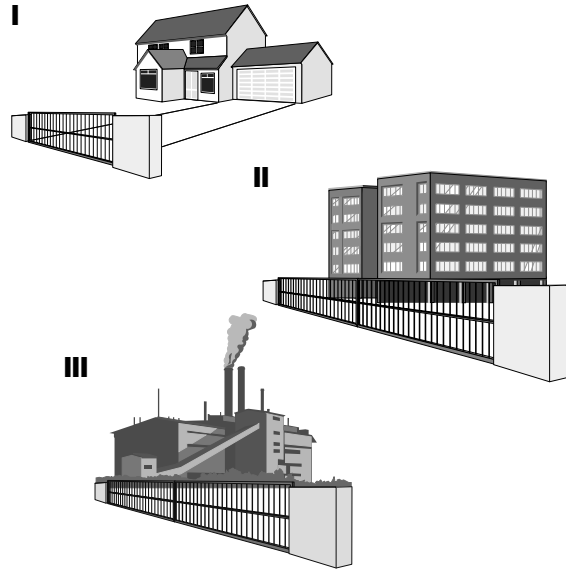

## SAFETY ACCESSORY SELECTION

All UL325 compliant LiftMaster gate operators will accept external entrapment protection devices to protect people from motorized gate systems. UL325 requires that the type of entrapment protection correctly matches each gate application. Below are the four types of entrapment protection systems recognized by UL325 for use on this operator.

### ENTRAPMENT PROTECTION TYPES

- Type A: Inherent obstruction sensing system, self-contained within the operator. This system must sense and initiate the reverse of the gate within two seconds of contact with a solid object.
- Type B1: Connections provided for a non-contact device, such as a photoelectric eye can be used as a secondary protection.
- Type B2: Connections provided for a contact sensor. A contact device such as a gate edge can be used for secondary protection.
- Type E: Built-in audio alarm. Examples include sirens, horns or buzzers.

**NOTE:** UL requires that all installations must have warning signs placed in plain view on both sides of the gate to warn pedestrians of the dangers of motorized gate systems.

## UL325 ENTRAPMENT PROTECTION REQUIREMENTS

### GATE OPERATOR ENTRAPMENT PROTECTION

UL325 Installation	Swing & Gate Barrier (Arm) Operator	
	Primary Type	Secondary Type
CLASS I CLASS II	A	A, B1 or B2
CLASS III	A, B1 or B2	A, B1, B2 or E

The chart above illustrates the entrapment protection requirements for each of the three UL325 classes.

In order to complete a proper installation you must satisfy the entrapment protection chart shown above. That means that the installation must have one primary means of entrapment protection and one independent secondary means of entrapment protection. Both primary and secondary entrapment protection methods must be designed, arranged or configured to protect against entrapments in both the open and close directions of gate travel.

**For Example:** For a slide gate system that is installed on a single-family residence (UL325 Class I) you must provide the following: As your primary type of entrapment protection you must provide Type A inherent (built into the operator) entrapment sensing and at least one of the following as your secondary entrapment protection: Type B1- Non-contact sensors such as photoelectric eyes, Type B2- Contact sensors such as gate edges.

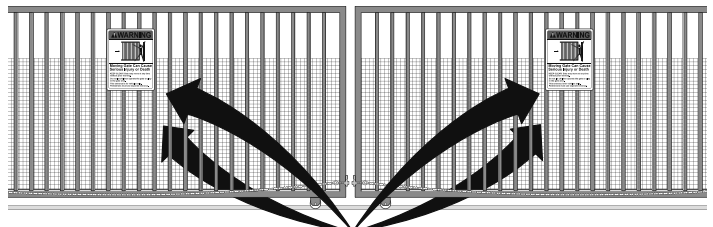

# SAFETY » SAFETY INSTALLATION INFORMATION

1. Vehicular gate systems provide convenience and security. Gate systems are comprised of many component parts. The gate operator is only one component. Each gate system is specifically designed for an individual application.
2. Gate operating system designers, installers and users must take into account the possible hazards associated with each individual application. Improperly designed, installed or maintained systems can create risks for the user as well as the bystander. Gate systems design and installation must reduce public exposure to potential hazards.
3. A gate operator can create high levels of force in its function as a component part of a gate system. Therefore, safety features must be incorporated into every design. Specific safety features include:
  - Gate Edges
  - Guards for Exposed Rollers
  - Photoelectric Sensors
  - Screen Mesh
  - Vertical Posts
  - Instructional and Precautionary Signage
4. Install the gate operator only when:
  - a. The operator is appropriate for the construction and the usage class of the gate.
  - b. All openings of a horizontal slide gate are guarded or screened from the bottom of the gate to a minimum of 4 feet (1.2 m) above the ground to prevent a 2-1/4 inch (6 cm) diameter sphere from passing through the openings anywhere in the gate, and in that portion of the adjacent fence that the gate covers in the open position.
  - c. All exposed pinch points are eliminated or guarded, and guarding is supplied for exposed rollers.
5. The operator is intended for installation only on gates used for vehicles. Pedestrians must be supplied with a separate access opening. The pedestrian access opening shall be designed to promote pedestrian usage. Locate the gate such that persons will not come in contact with the vehicular gate during the entire path of travel of the vehicular gate.

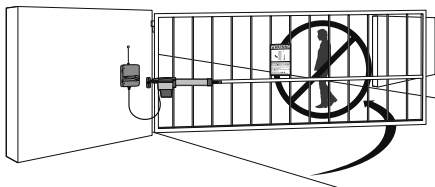

6. The gate must be installed in a location so that enough clearance is supplied between the gate and adjacent structures when opening and closing to reduce the risk of entrapment. Swinging gates shall not open into public access areas.
7. The gate must be properly installed and work freely in both directions prior to the installation of the gate operator.
8. Controls intended for user activation must be located at least 6 feet (1.83 m) away from any moving part of the gate and where the user is prevented from reaching over, under, around or through the gate to operate the controls. Outdoor or easily accessible controls shall have a security feature to prevent unauthorized use.



9. The Stop and/or Reset (if provided separately) must be located in the line-of-sight of the gate. Activation of the reset control shall not cause the operator to start.
10. A minimum of two (2) WARNING SIGNS shall be installed, one on each side of the gate where easily visible.

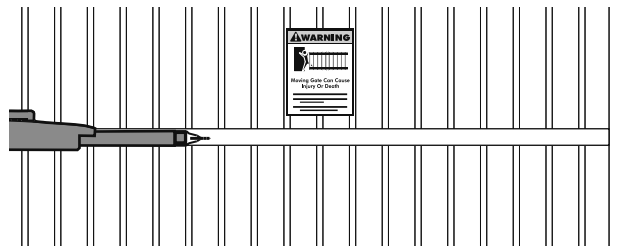

11. For a gate operator utilizing a non-contact sensor:
  - a. Reference owner's manual regarding placement of non-contact sensor for each type of application.
  - b. Care shall be exercised to reduce the risk of nuisance tripping, such as when a vehicle trips the sensor while the gate is still moving.
  - c. One or more non-contact sensors shall be located where the risk of entrapment or obstruction exists, such as the perimeter reachable by a moving gate or barrier.
12. For a gate operator utilizing a contact sensor such as an edge sensor:
  - a. One or more contact sensors shall be located where the risk of entrapment or obstruction exists, such as at the leading edge, trailing edge and post mounted both inside and outside of a vehicular horizontal slide gate.
  - b. One or more contact sensors shall be located at the bottom edge of a vehicular vertical lift gate.
  - c. A hard wired contact sensor shall be located and its wiring arranged so the communication between the sensor and the gate operator is not subject to mechanical damage.
  - d. A wireless contact sensor such as the one that transmits radio frequency (RF) signals to the gate operator for entrapment protection functions shall be located where the transmission of the signals are not obstructed or impeded by building structures, natural landscaping or similar obstruction. A wireless contact sensor shall function under the intended end-use conditions.
  - e. One or more contact sensors shall be located on the inside and outside leading edge of a swing gate. Additionally, if the bottom edge of a swing gate is greater than 6 inches (152 mm) above the ground at any point in its arc of travel, one or more contact sensors shall be located on the bottom edge.
  - f. One or more contact sensors shall be located at the bottom edge of a vertical barrier (arm).

# SAFETY » GATE CONSTRUCTION INFORMATION

Vehicular gates should be installed in accordance with ASTM F2200: Standard Specification for Automated Vehicular Gate Construction. For a copy, contact ASTM directly at 610-832-9585 or [www.astm.org](http://www.astm.org).

## 1. GENERAL REQUIREMENTS

- 1.1 Gates shall be constructed in accordance with the provisions given for the appropriate gate type listed, refer to ASTM F2200 for additional gate types.
- 1.2 Gates shall be designed, constructed and installed to not fall over more than 45 degrees from the vertical plane, when a gate is detached from the supporting hardware.
- 1.3 Gates shall have smooth bottom edges, with vertical bottom edged protrusions not exceeding 0.50 inches (12.7 mm) when other than the exceptions listed in ASTM F2200.
- 1.4 The minimum height for barbed tape shall not be less than 8 feet (2.44 m) above grade and for barbed wire shall not be less than 6 feet (1.83 m) above grade.
- 1.5 An existing gate latch shall be disabled when a manually operated gate is retrofitted with a powered gate operator.
- 1.6 A gate latch shall not be installed on an automatically operated gate.
- 1.7 Protrusions shall not be permitted on any gate, refer to ASTM F2200 for Exceptions.
- 1.8 Gates shall be designed, constructed and installed such that their movement shall not be initiated by gravity when an automatic operator is disconnected.
- 1.9 A pedestrian gate shall not be incorporated into a vehicular gate panel or that portion of the adjacent fence that the gate covers in the open position.

## 2. SPECIFIC APPLICATIONS

- 2.1 Any non-automated gate that is to be automated shall be upgraded to conform to the provisions of this specification.
- 2.2 This specification shall not apply to gates generally used for pedestrian access and to vehicular gates not to be automated.
- 2.3 Any existing automated gate, when the operator requires replacement, shall be upgraded to conform to the provisions of this specification in effect at that time.

## 3. VEHICULAR HORIZONTAL SLIDE GATES

- 3.1 The following provisions shall apply to Class I, Class II and Class III vehicular horizontal slide gates:
  - 3.1.1 All weight bearing exposed rollers 8 feet (2.44 m), or less, above grade shall be guarded or covered.
  - 3.1.2 All openings located between 48 inches (1.22 m) and 72 inches (1.83 m) above grade shall be designed, guarded or screened to prevent a 4 inch (102 mm) diameter sphere from passing through the openings anywhere in the gate, and in that portion of the adjacent fence that covers in the open position.

- 3.1.3 A gap, measured in the horizontal plane parallel to the roadway, between a fixed stationary object nearest the roadway, (such as a gate support post) and the gate frame when the gate is in either the fully open position or the fully closed position, shall not exceed 2-1/4 inches (57 mm), refer to ASTM F2200 for Exception.
- 3.1.4 Positive stops shall be required to limit travel to the designed fully open and fully closed positions. These stops shall be installed at either the top of the gate, or at the bottom of the gate where such stops shall horizontally or vertically project no more than is required to perform their intended function.
- 3.1.5 All gates shall be designed with sufficient lateral stability to assure that the gate will enter a receiver guide, refer to ASTM F2200 for panel types.
- 3.2 The following provisions shall apply to Class IV vehicular horizontal slide gates:
  - 3.2.1 All weight bearing exposed rollers 8 feet (2.44 m), or less, above grade shall be guarded or covered.
  - 3.2.2 Positive stops shall be required to limit travel to the designed fully open and fully closed positions. These stops shall be installed at either the top of the gate, or at the bottom of the gate where such stops shall horizontally or vertically project no more than is required to perform their intended function.

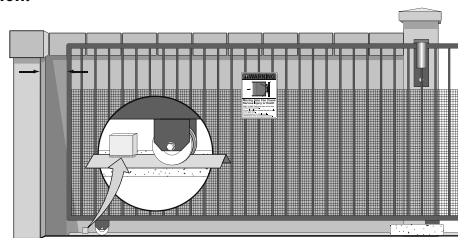

## 4. VEHICULAR HORIZONTAL SWING GATES

- 4.1 The following provisions shall apply to Class I, Class II and Class III vehicular horizontal swing gates:
  - 4.1.1 Gates shall be designed, constructed and installed so as not to create an entrapment area between the gate and the supporting structure or other fixed object when the gate moves toward the fully open position, subject to the provisions in the 4.1.1.1 and 4.1.1.2.
    - 4.1.1.1 The width of an object (such as a wall, pillar or column) covered by a swing gate when in the open position shall not exceed 4 inches (102 mm), measured from the centerline of the pivot point of the gate, refer to ASTM F2200 for exception.
    - 4.1.1.2 Except for the zone specified in Section 4.1.1.1, the distance between a fixed object such as a wall, pillar or column, and a swing gate when in the open position shall not be less than 16 inches (406 mm), refer to ASTM F2200 for exception.
  - 4.2 Class IV vehicular horizontal swing gates shall be designed, constructed and installed in accordance with security related parameters specific to the application in question.

# SAFETY » IMPORTANT SAFETY INFORMATION

## INSTALLATION

### WARNING

To prevent **SERIOUS INJURY** or **DEATH**; one or more non-contact sensors shall be located where the risk of entrapment or obstruction exists.

To prevent **SERIOUS INJURY** or **DEATH** from a moving gate:

- Entrapment protection devices **MUST** be installed to protect anyone who may come near a moving gate.
- Locate entrapment protection devices to protect in **BOTH** the open and close gate cycles.
- Locate entrapment protection devices to protect between moving gate and **RIGID** objects, such as posts.
- A swinging gate shall **NOT** open into public access ways.

To prevent **SERIOUS INJURY** or **DEATH** from a moving gate:

- Install warning signs on the front and back of the gate in **PLAIN VIEW**.
- Permanently secure each warning sign in a suitable manner using fastening holes.

**ALWAYS** wear protective gloves and eye protection when changing the battery or working around the battery compartment.

- **DO NOT** use flooded lead acid battery.
- Flooded lead acid batteries will produce gases when discharging and recharging which can explode.
- **DO NOT** dispose of battery in fire. Battery may explode. Check with local codes for disposal instructions.

## WIRING

### WARNING

To reduce the risk of **SEVERE INJURY** or **DEATH**:

- **ANY** maintenance to the operator or in the area near the operator **MUST NOT** be performed until disconnecting the electrical power and locking-out the power via the operator power switch. Upon completion of maintenance the area **MUST** be cleared and secured, at that time the unit may be returned to service.
- Disconnect power at the fuse box **BEFORE** proceeding. Operator **MUST** be properly grounded and connected in accordance with local electrical codes.  
**NOTE:** The operator should be on a separate fused line of adequate capacity.
- **ALL** electrical connections **MUST** be made by a qualified individual.

- **DO NOT** install **ANY** wiring or attempt to run the operator without consulting the wiring diagram. We recommend that you install an optional reversing edge **BEFORE** proceeding with the control station installation.
- **ALL** power wiring should be on a dedicated circuit and well protected. The location of the power disconnect should be visible and clearly labeled.
- **ALL** power and control wiring **MUST** be run in separate conduit.
- **BEFORE** installing power wiring or control stations be sure to follow **ALL** specifications and warnings described below. Failure to do so may result in **SEVERE INJURY** to persons and/or damage to operator.

### CAUTION

To **AVOID** damaging plug-in transformer, it **MUST** be enclosed in a suitable weatherproof enclosure and provided with proper weatherproof fixtures.

To **AVOID** damaging gas, power or other underground utility lines, contact underground utility locating companies **BEFORE** digging.

To reduce the risk of **FIRE** or **INJURY** to persons use only LiftMaster part #K74-30762 for replacement batteries.

## ADJUSTMENT

### WARNING

Without a properly installed safety reversal system, persons (particularly small children) could be **SERIOUSLY INJURED** or **KILLED** by a closing gate.

- Too much force on gate will interfere with proper operation of safety reversal system.
- **NEVER** increase force beyond minimum amount required to close gate.
- **NEVER** use force adjustments to compensate for a binding or sticking gate.
- If one control (force or travel limits) is adjusted, the other control may also need adjustment.
- After **ANY** adjustments are made, the safety reversal system **MUST** be tested. Gate **MUST** reverse on contact with a rigid object.

# SAFETY » IMPORTANT SAFETY INFORMATION

## OPERATION AND MAINTENANCE

### **WARNING**

- READ AND FOLLOW ALL INSTRUCTIONS.
- NEVER let children operate or play with gate controls. Keep the remote control away from children.
- ALWAYS keep people and objects away from the gate. NO ONE SHOULD CROSS THE PATH OF THE MOVING GATE.
- Test the gate operator monthly. The gate MUST reverse on contact with a rigid object or stop when an object activates the non-contact sensors. After adjusting the force or the limit of travel, retest the gate operator. Failure to adjust and retest the gate operator properly can increase the risk of INJURY or DEATH.
- Use the emergency release ONLY when the gate is not moving.
- KEEP GATES PROPERLY MAINTAINED. Read the owner's manual. Have a qualified service person make repairs to gate hardware.
- The entrance is for vehicles ONLY. Pedestrians MUST use separate entrance.
- Disconnect ALL power before performing ANY maintenance.
- ALL maintenance MUST be performed by a LiftMaster professional.
- SAVE THESE INSTRUCTIONS.

### **CAUTION**

To reduce the risk of FIRE or INJURY to persons use only LiftMaster part #K74-30762 for replacement batteries.

To avoid SERIOUS personal INJURY or DEATH from electrocution, DISCONNECT electrical power to operator BEFORE proceeding.

## TROUBLESHOOTING

### **WARNING**

To protect against fire and electrocution:

- Disconnect power and battery BEFORE installing or servicing operator.

For continued protection against fire:

- Replace ONLY with fuse of same type and rating.

# INTRODUCTION » OPERATOR SPECIFICATIONS + CARTON INVENTORY

## OPERATOR SPECIFICATIONS

Operating Cycles:	<b>100 per day</b>
Main Supply (Motor):	<b>24 Vdc</b>
Current Consumption:	<b>2A</b>
Power Consumption:	<b>48 Watts</b>
Battery Charger Supply:	<b>26 Vac, 29VA or 36 Vdc, 40VA</b>
Maximum Gate Width:	<b>16 feet (4.9 m)</b>
Maximum Gate Weight:	<b>550 lbs. (249.5 kg)</b>
Protection Class:	<b>NEMA 3R</b>
Travel Speed:	<b>14-18 seconds for a 90° opening</b>
Rated Operating Time:	<b>4 Minutes</b>
Temperature:	<b>-20° C to + 50° C</b> <b>-4° F to + 122° F</b>
Main Supply (Control)	
Dedicated Circuit:	<b>120V~/60Hz</b>
Absorbed Power:	<b>0.75 Watts</b>
Protection Fuse Battery:	<b>ATC 20A</b>

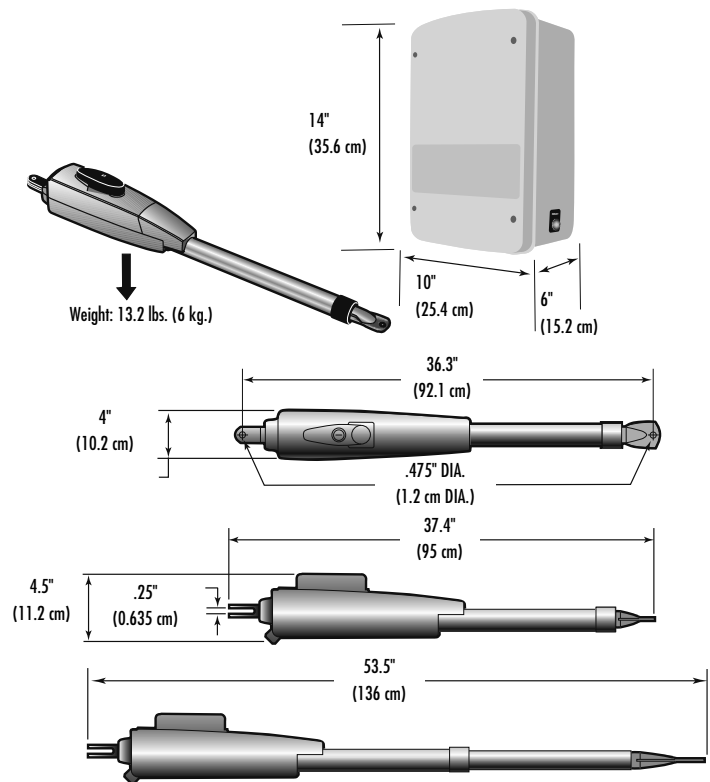

## CARTON INVENTORY

Carton inventory is based on a Single Operator. For Primary (Gate 1) and Secondary (Gate 2) installation the carton inventory is doubled except for control box.

- Standard Control Box (1)
- Hardware Bag (1)
- Gate Operator Arm
- Motor Cable - Six Conductor, 9 feet (2.7 m)
- Warning Sign (2)
- Battery (2)
- Plug-in Transformer (1)

### LA400-S (SECOND GATE OPERATOR ARM)

- Motor Cable - Six Conductor, 40 feet (12.2 m)
- Junction Box - IP56 (1)
- Phillips Head Mounting Screws (4)
- Anchors (4)
- Terminal Block - Twelve Connectors (1)

## HARDWARE INVENTORY

- Post Bracket (1)
- Pull-to-Open Bracket (1)
- Hex Bolt 5/16"-18 X 1-1/2" (5)
- Square Neck Carriage Bolt 3/8"-16 X 6" (2)
- Hex Nut 3/8"-16 (2)
- Hex Nut 5/16"-18 (5)
- Flat Washer 5/16" (5)
- Flat Washer 3/8" (5)
- Lock Washer 5/16" (5)
- Lock Washer 3/8" (5)
- Gate Mounting Bracket (1)
- Hairpin Clip (2)
- Pin (2)
- Hex Bolt 3/8"-16 X 1-1/2" (1)
- Bolt 2-3/4" (2)
- Keylock Cap (1)
- Keys (2)



# INTRODUCTION » ADDITIONAL ITEMS NEEDED FOR INSTALLATION + TOOLS NEEDED

## ADDITIONAL ITEMS NEEDED FOR INSTALLATION

PERMANENT FASTENERS FOR WARNING SIGN

EARTH GROUND ROD (OPTIONAL)

POWER WIRE:

120 VAC POWER WIRE (STRANDED COPPER WIRE)	
Wire Gauge 16	100 feet (30 m)
Wire Gauge 10	1000 feet (305 m)
<b>OR</b>	
24 VAC TRANSFORMER (STRANDED COPPER WIRE)	
Wire Gauge 14	500 feet (152 m)
Wire Gauge 12	1000 feet (305 m)

## TOOLS NEEDED

During assembly, installation and adjustment of the operator, instructions will call for tools as illustrated below.

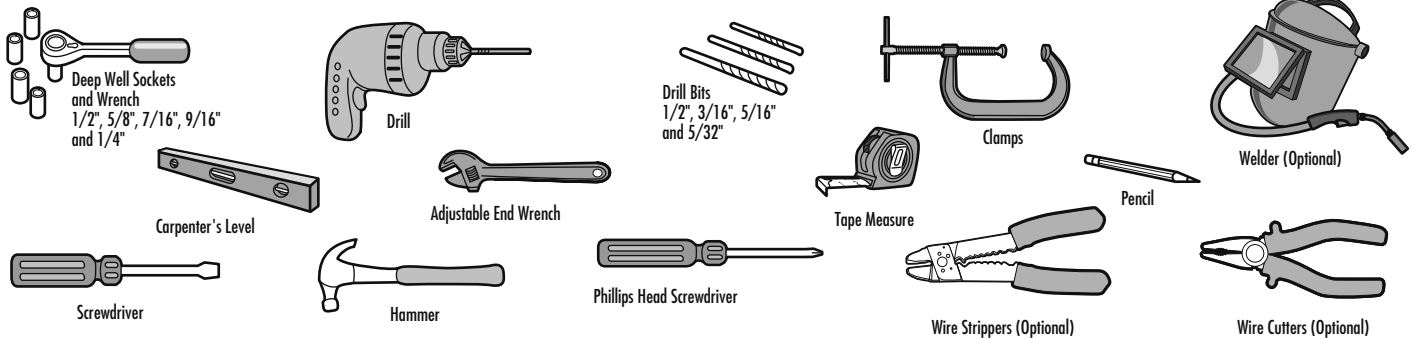

# INSTALLATION » OVERVIEW OF TYPICAL INSTALLATION

## LEFT-HAND GATE

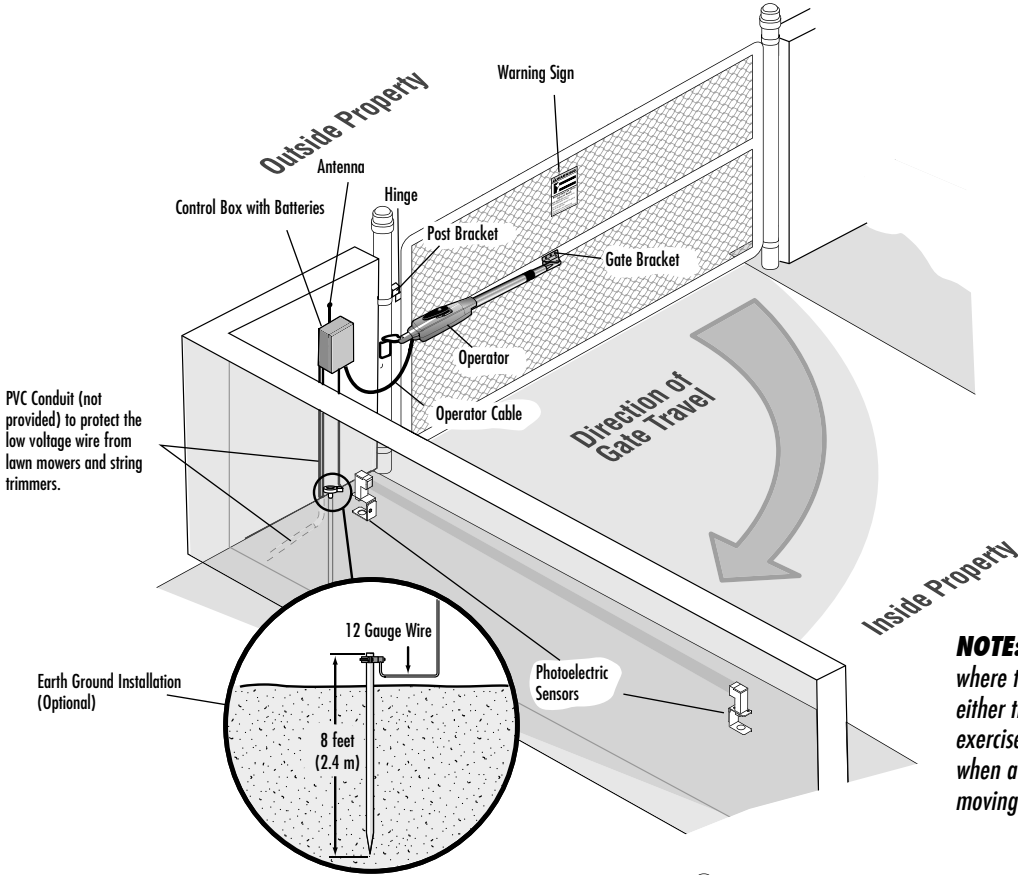

**NOTE:** One or more non-contact sensors shall be located where the risk of entrapment or obstruction exists at either the opening or closing direction. Care shall be exercised to reduce the risk of nuisance tripping, such as when a vehicle trips the sensor while the gate is still moving.

## RIGHT-HAND GATE

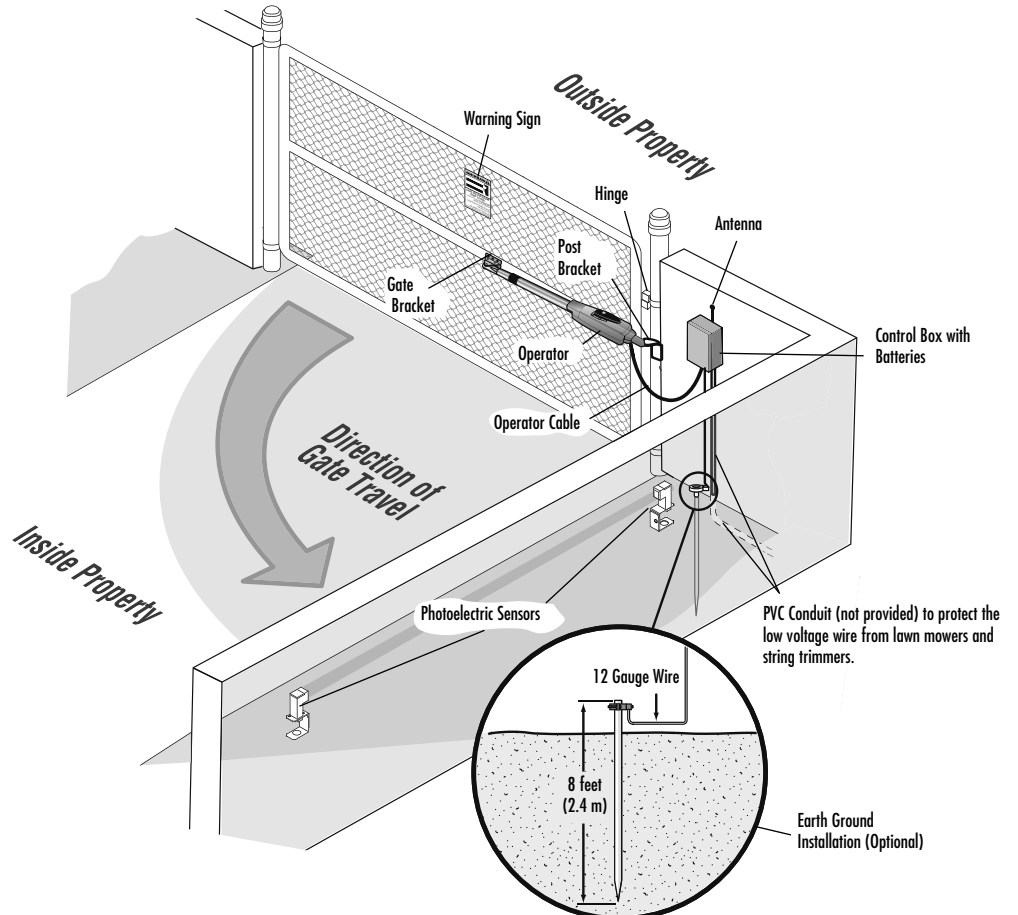

# INSTALLATION » OVERVIEW OF TYPICAL INSTALLATION

## DUAL GATE

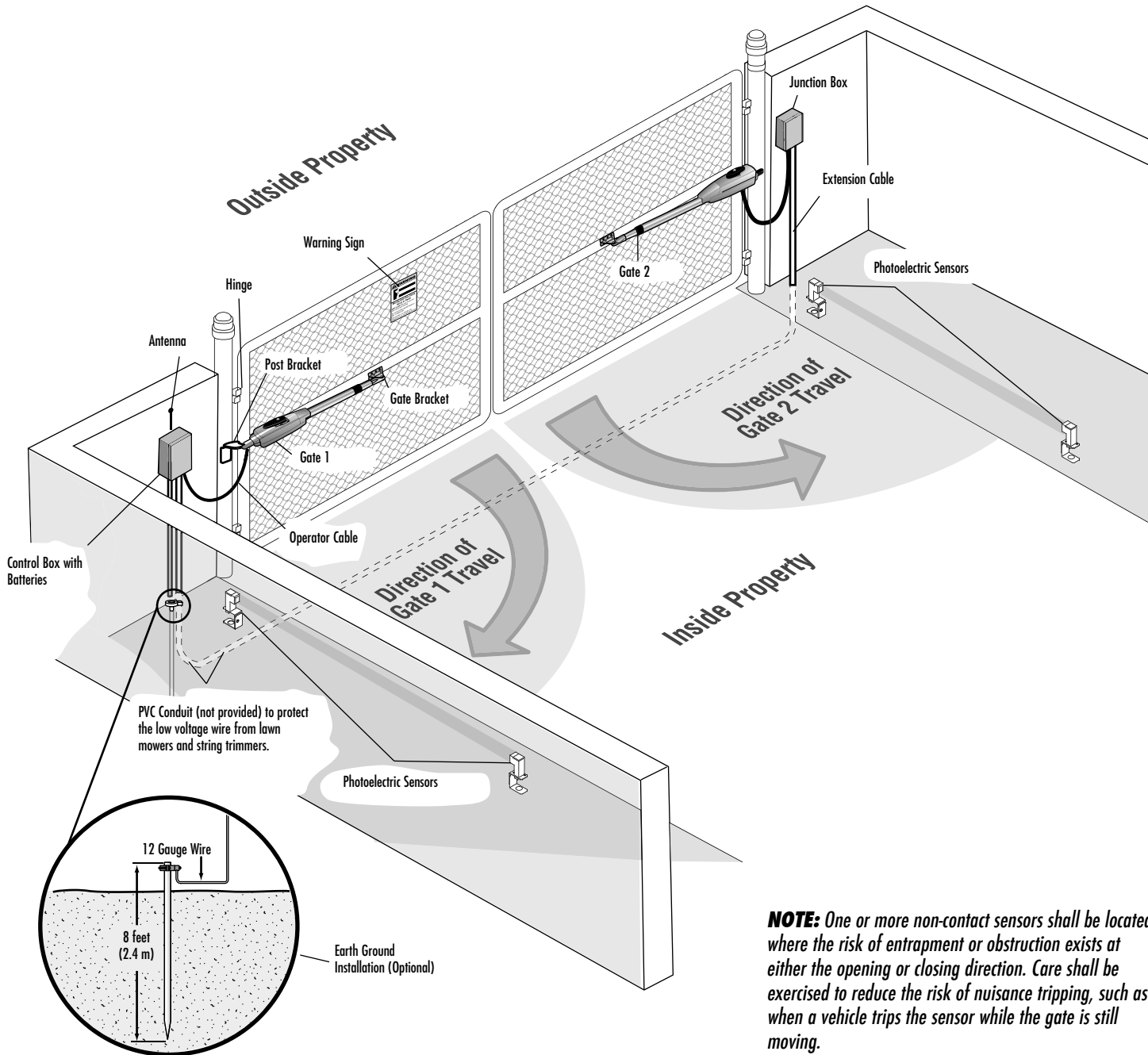

# INSTALLATION » CHECK YOUR GATE + MOUNTING OPTIONS

## CHECK YOUR GATE

- A** Gate MUST be level. Gate and gate post MUST be plumb.
- B** Remove ANY/ALL wheels from the bottom of gate.
- C** Gate MUST NOT hit or drag across ground.
- D** Gate MUST swing freely and be supported entirely by its hinges.

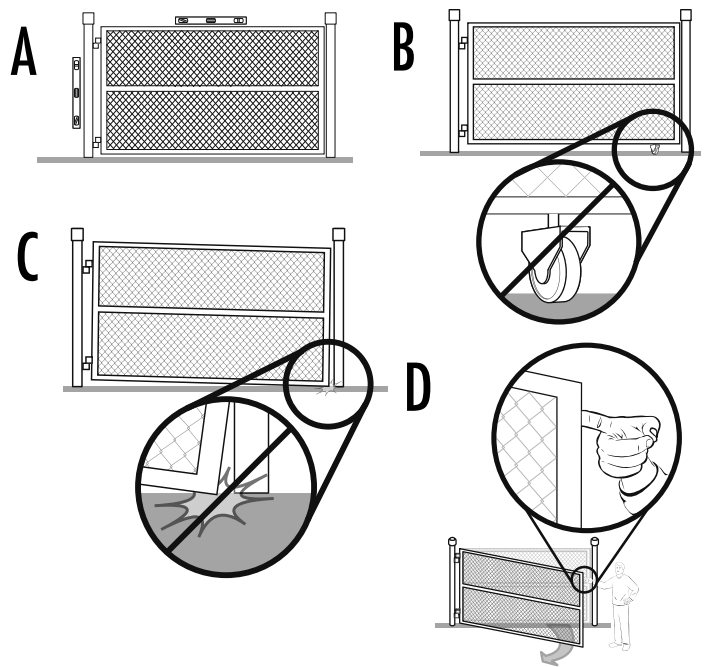

## MOUNTING OPTIONS

Mounting locations vary depending on type and style of your gate. Minimum distance from the ground should not be less than 4 inches (10.2 cm) from the bottom of the gate operator arm.

### RECOMMENDED:

- = Gate post bracket mounting locations
- = Gate bracket mount locations

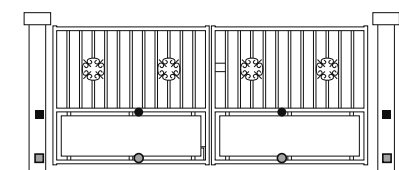
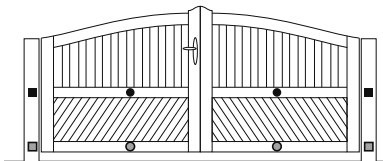
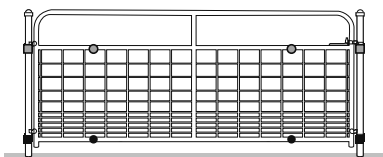
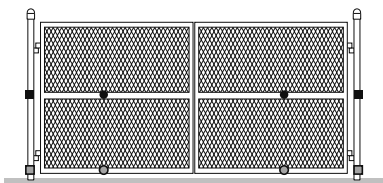

### OPTIONAL:

- = Gate post bracket mounting locations
- = Gate bracket mount locations

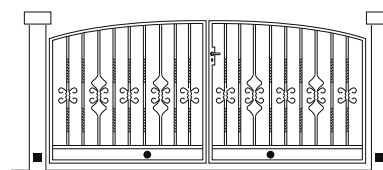
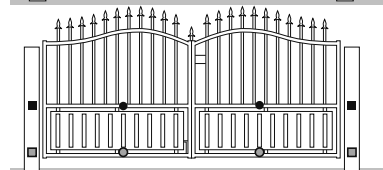
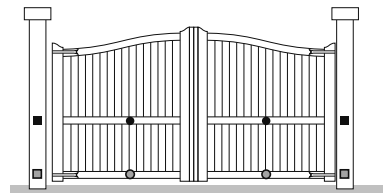
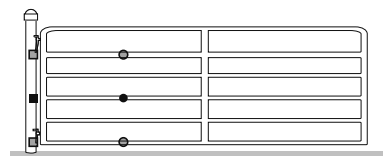

# INSTALLATION » MANUAL RELEASE + DETERMINE POSITION OF THE PULL-TO-OPEN BRACKET + DETERMINE POSITION OF THE "OPTIONAL" PUSH-TO-OPEN BRACKET

## MANUAL RELEASE

1 Insert the key into the lock and turn it 180° counterclockwise.

2 Turn the release lever 180° counterclockwise.

The operator is now in manual mode.

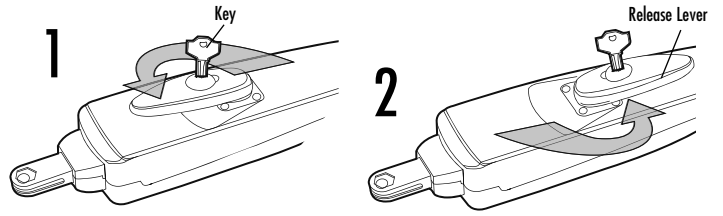

## DETERMINE POSITION OF THE PULL-TO-OPEN BRACKET

The Pull-to-Open bracket can be assembled to work on a **Left-Hand** or a **Right-Hand** gate.

1 Review the gate types and select the type of installation you will require.

**NOTE:** If the **Pull-to-Open** bracket is not assembled correctly you will damage the operator.

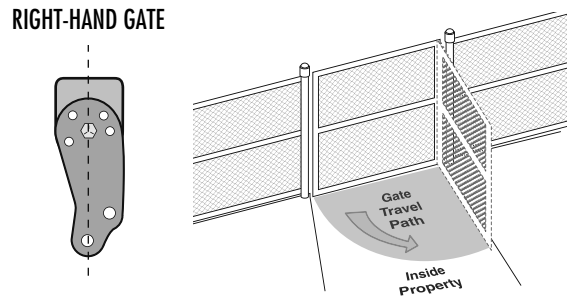
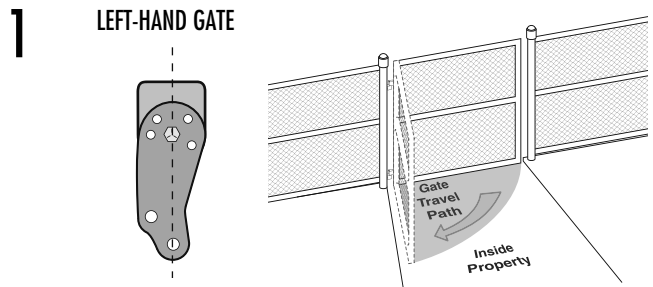

OR

## DETERMINE POSITION OF THE "OPTIONAL" PUSH-TO-OPEN BRACKET

(NOT PROVIDED. SEE ACCESSORIES)

The Push-to-Open bracket can be assembled to work on a **Left-Hand** or a **Right-Hand** gate.

1 Review the gate types and select the type of installation you will require.

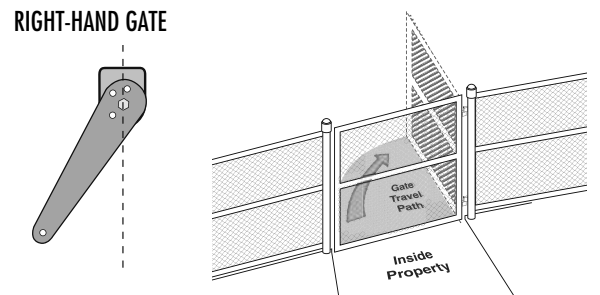
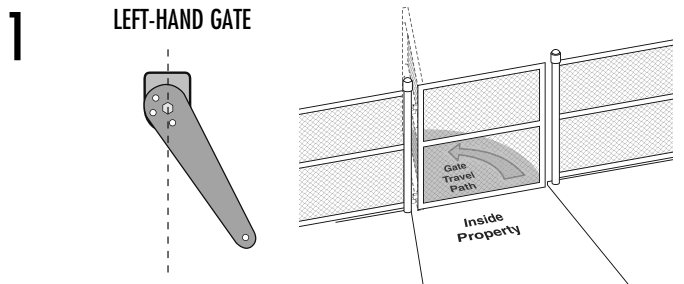

# INSTALLATION » ASSEMBLE GATE POST BRACKET (PULL-TO-OPEN) + ATTACH BRACKETS TO GATE OPERATOR

All the illustrations on the following pages display a typical Left-Hand Gate installation. For Push-to-Open installations refer to instructions with Push-to-Open kit 50-19503.

## ASSEMBLE GATE POST BRACKET (PULL-TO-OPEN)

- 1 Assemble gate post bracket by placing Pull-to-Open bracket on top of post bracket.
- 2 Insert the bolt through both brackets and secure with washer, lock washer and nut.

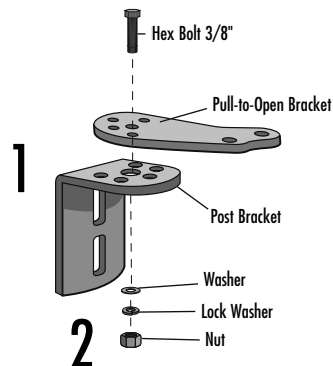

## ATTACH BRACKETS TO GATE OPERATOR

- 1 Attach post bracket assembly to operator using pins and hairpin clips.
- 2 Attach gate bracket to operator using pins and hairpin clips.

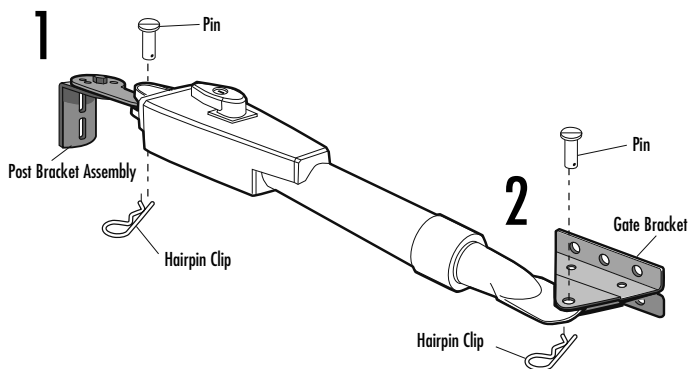

# INSTALLATION » DETERMINE MOUNTING LOCATION + MEASURING AND MARKING FOR THE GATE BRACKET

## DETERMINE MOUNTING LOCATION

The gate post bracket assembly can be mounted several places on the gate post. Refer to the illustrations on page 11 for the ideal mounting location.

Refer to the illustrations to determine the appropriate dimensions for the Pull-to-Open bracket.

**NOTE:** It may be necessary to add shims (angle iron, sheets of metal or wood) to the gate post to achieve the required dimensions.

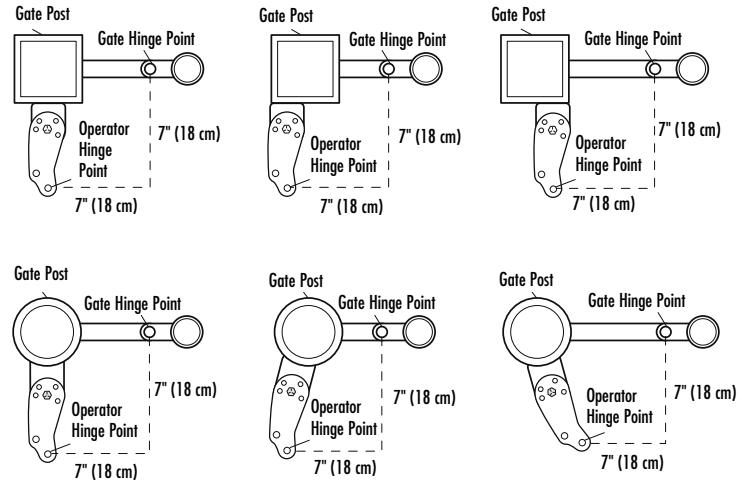

## MEASURING AND MARKING FOR THE GATE BRACKET

Before proceeding, begin with the gate in the fully closed position. There are two methods for determining the proper location of the post brackets:

- Paper template (Located on the back page of this manual. Must be cut out.)
- Tape measure.

Either method will work depending on preference.

### TEMPLATE METHOD

- 1 Close the gate.
- 2 Place the template (provided on the back page of this manual) under the center of the gate hinge point.
- 3 Use a screwdriver or dowel rod to temporarily mark the location in front of the gate post.

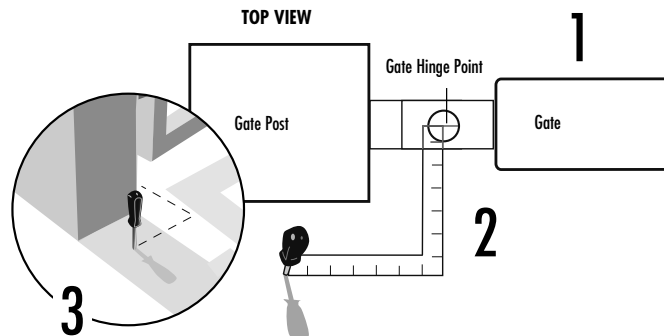

### TAPE MEASURE METHOD

- 1 Close the gate.
- 2 Place the measuring tape under the center of the gate hinge point and measure out 7 inches (18 cm).
- 3 Use a screwdriver or dowel rod to temporarily mark the location of the first measurement.
- 4 Measure 7 inches (18 cm) from the previous mark.
- 5 Use the screwdriver or dowel rod to mark the location of the second measurement.

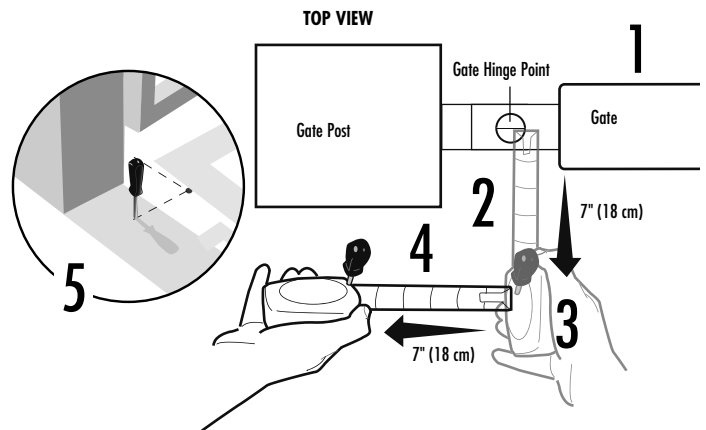

# INSTALLATION » POSITION GATE OPERATOR ON GATE

## POSITION GATE OPERATOR ON GATE

**NOTE:** The post bracket assembly can be mounted several places on the gate post. Refer to page 11 for mounting options.

- 1 Open the gate to desired open position (no greater than 100°) and hold operator against gate.
- 2 Place the operator arm against gate post at the desired position. Temporarily secure gate post bracket with clamp. **The gate operator (arm) must be level.**
- 3 Mark mounting holes on gate for reference. Temporarily secure the gate bracket using a clamp.
- 4 Align the Pull-to-Open bracket to a position as **CLOSE AS POSSIBLE** above the screwdriver or dowel rod.
- 5 Insert hex bolt through Pull-to-Open bracket and post bracket and secure with washer, lock washer and nut.

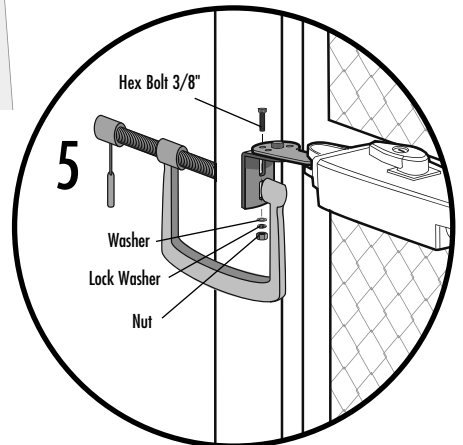
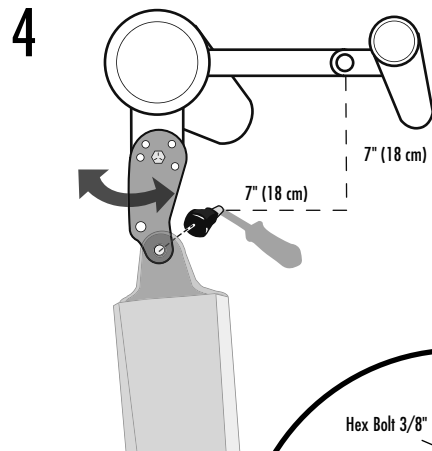
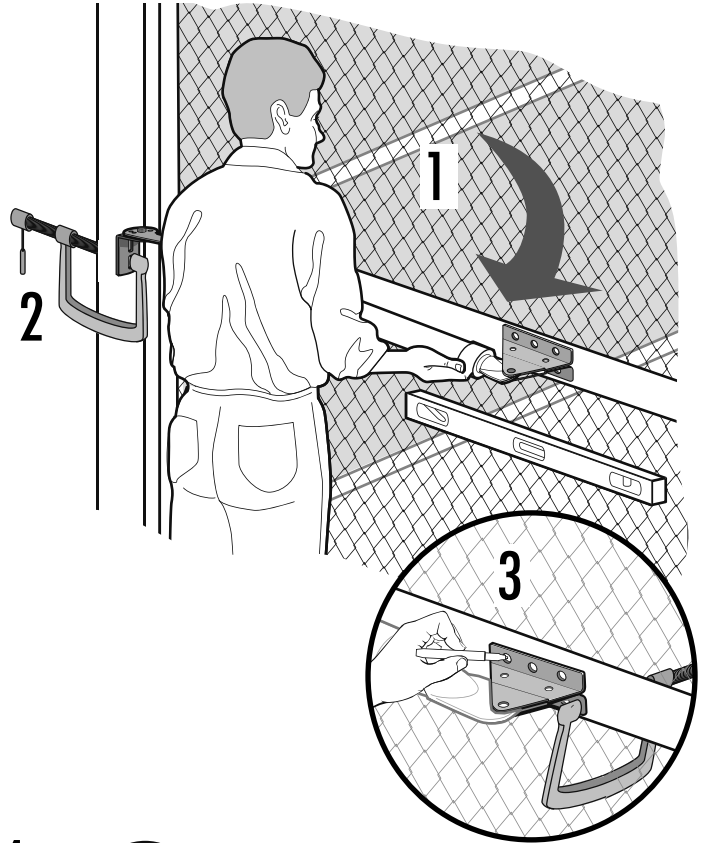



# INSTALLATION » TEST GATE TRAVEL + SECURE POST BRACKET TO GATE POST

## TEST GATE TRAVEL

**NOTE:** If gate does not open and close completely adjust the position of the gate bracket and mark new mounting holes.

- 1 Manually open and close the gate.
- 2 Ensure that the operator does not bind against the Pull-to-Open bracket.
- 3 Ensure that the piston does not bottom out.

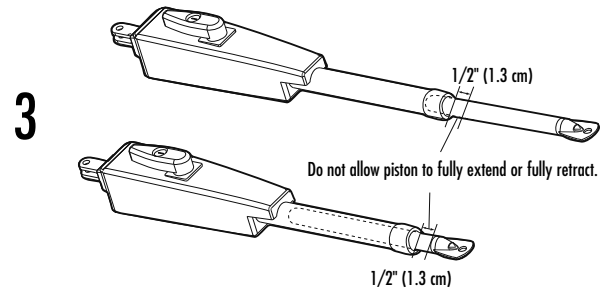
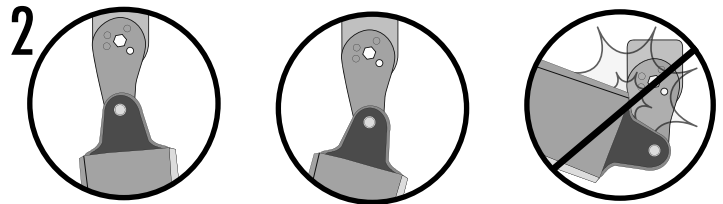
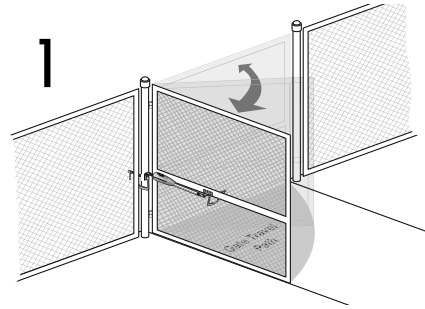

## SECURE POST BRACKET TO GATE POST

The gate operator (arm) must be level.

- 1 Mark holes for the post bracket. Remove the clamp and the operator, set aside.
- 2 Drill adequate holes in the gate post.
- 3 Secure the post bracket to the gate post using hardware.

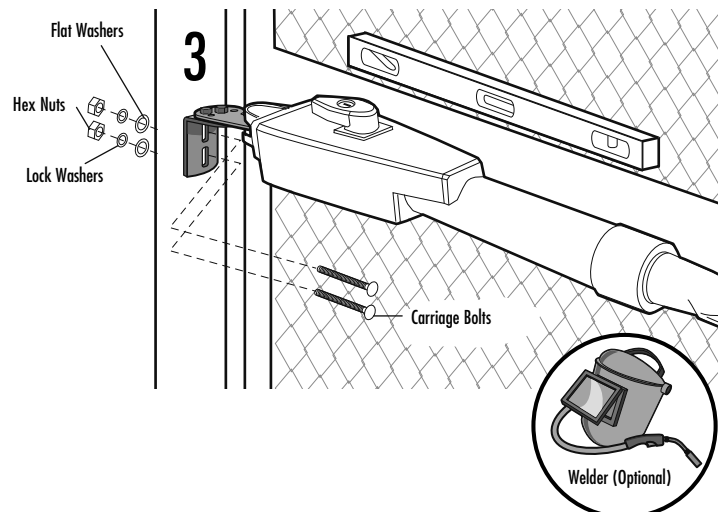
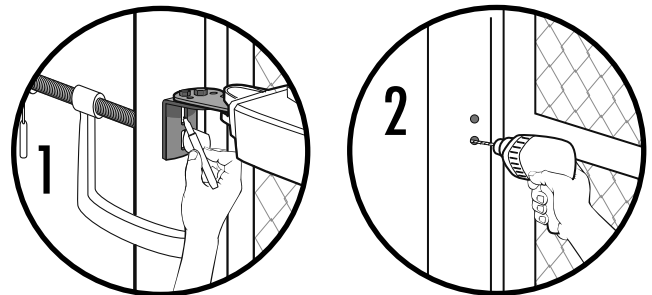

# INSTALLATION » SECURE GATE BRACKET TO GATE + WARNING SIGN PLACEMENT

## SECURE GATE BRACKET TO GATE

The gate operator (arm) must be level.

Some installations may require additional reinforcement be installed on the gate.

- 1 Drill holes in gate (or reinforcement, if necessary) that are large enough for the gate bracket mounting hardware.
- 2 Secure the gate operator to the gate using hardware (not provided).
- 3 Manually move the gate to verify that it opens and closes fully.

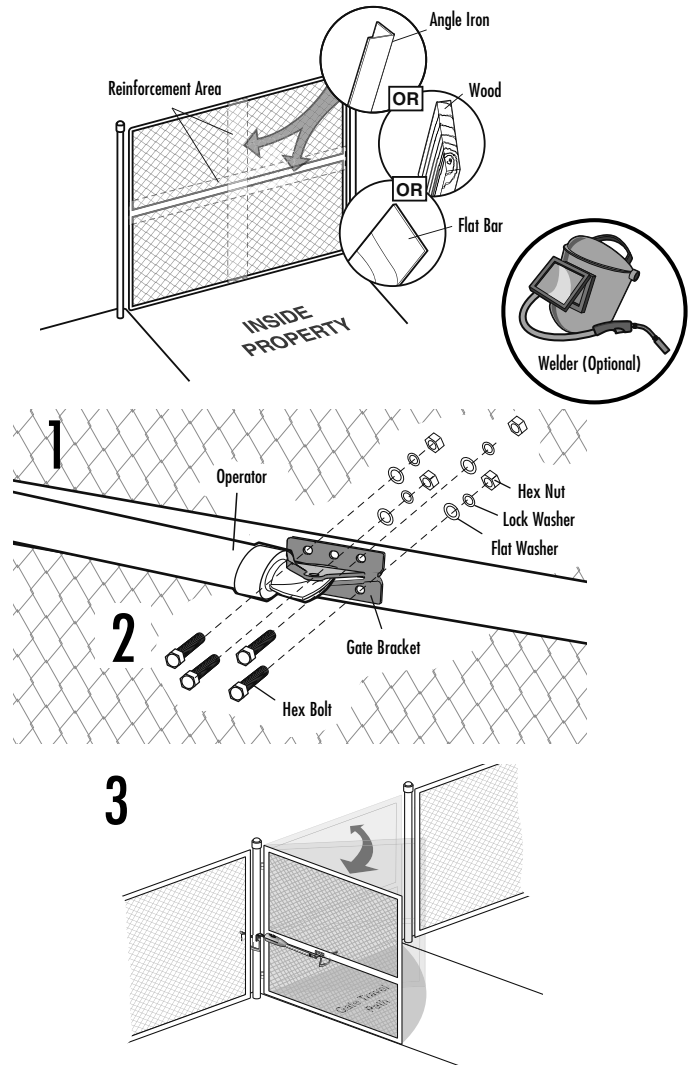

## WARNING SIGN PLACEMENT

Warning signs **MUST** be installed on both sides of the gate and in plain view.

- 1 Fasten warning signs to the gate with cable ties.

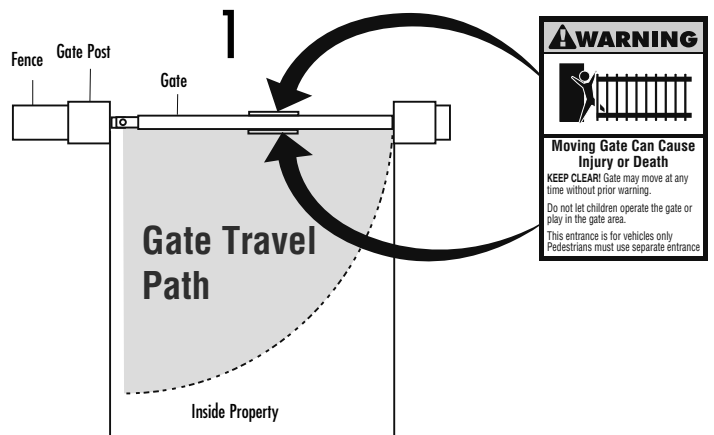

**If installing a 2nd operator, repeat the previous installation steps for the second gate before proceeding to the next page.**

# INSTALLATION » STANDARD CONTROL BOX

## MOUNT THE CONTROL BOX

The control box **MUST** be mounted within 5 feet (1.5 m) of the gate operator. Mount the control box as high as possible for best radio reception.

- 1 Remove screws and open the control box.
- 2 Disconnect the reset button, alarm, and coaxial connector.
- 3 Loosen screws to remove the control board and mounting bracket.
- 4 Remove the control board.
- 5 Remove batteries and set aside.
- 6 Select mounting holes and knock out using a screwdriver and hammer.
- 7 Secure the control box to mounting surface using the appropriate hardware (not provided).
  - A. Post
  - B. Wall
  - C. Column

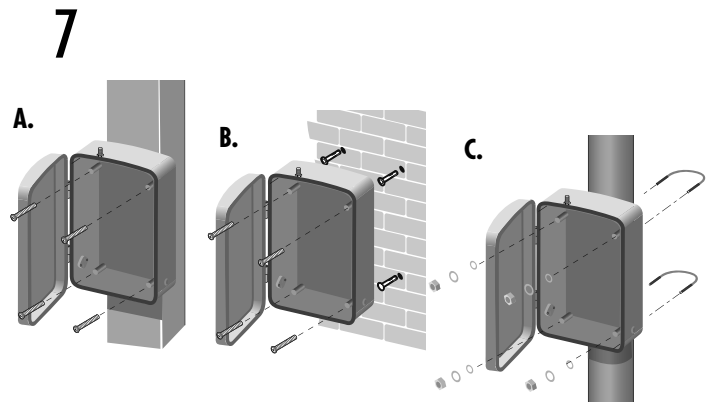
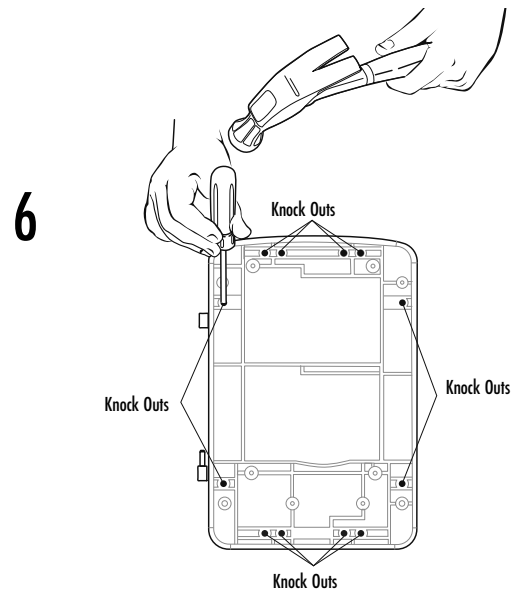
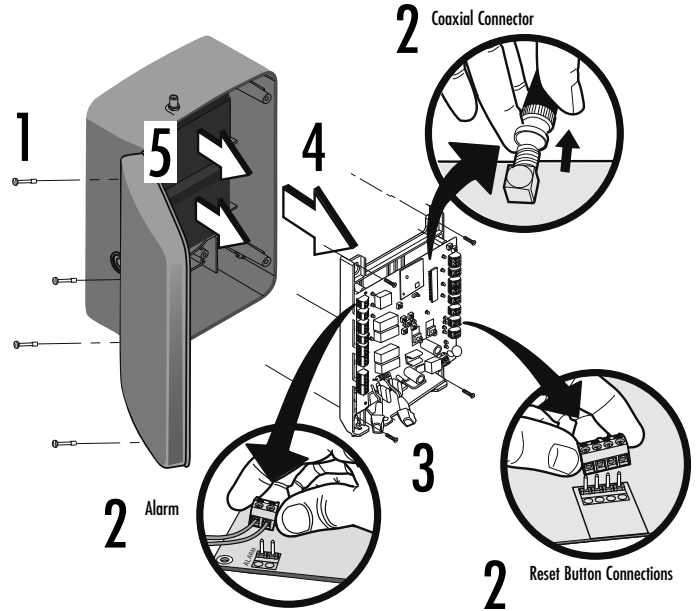

# INSTALLATION » STANDARD CONTROL BOX

## INSTALL THE CONTROL BOARD

**NOTE:** Make sure the battery leads are on the left side of the control box and not pinched.

- 1 Attach the antenna.
- 2 Reinstall the batteries, control board, alarm and reset button.

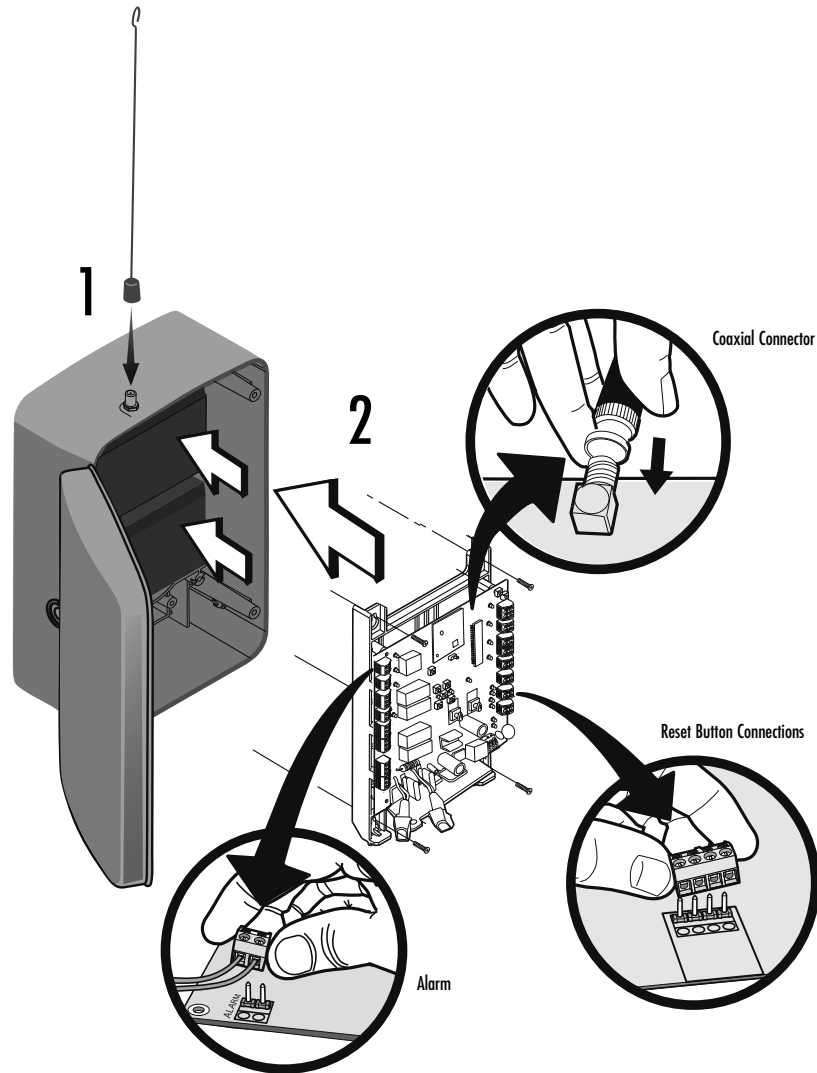

# INSTALLATION » LARGE METAL CONTROL BOX (XLM)

## MOUNT THE CONTROL BOX (XLM)

The control box **MUST** be mounted within 5 feet (1.5 m) of the gate operator. Mount the control box as high as possible for best radio reception.

**1** Open the control box. The control box door may be removed by opening the door 90°. Lift the door from the hinges and set aside until the installation is complete.

**2** The control box can be mounted to a post with 'U' bolts. See chart below. The knock out will accommodate a 3/8" diameter 'U' bolt.

Type and Size	'U' Bolt Opening
Standard 3" Round Pipe	3-1/2"
Standard 4" Square Post	4"
Standard 6" Square Post	6"

**3** Select center mounting holes (top and bottom) knock out using a screwdriver and hammer. Use knock outs located at the 4 corners of the control box for wall or column mounting.

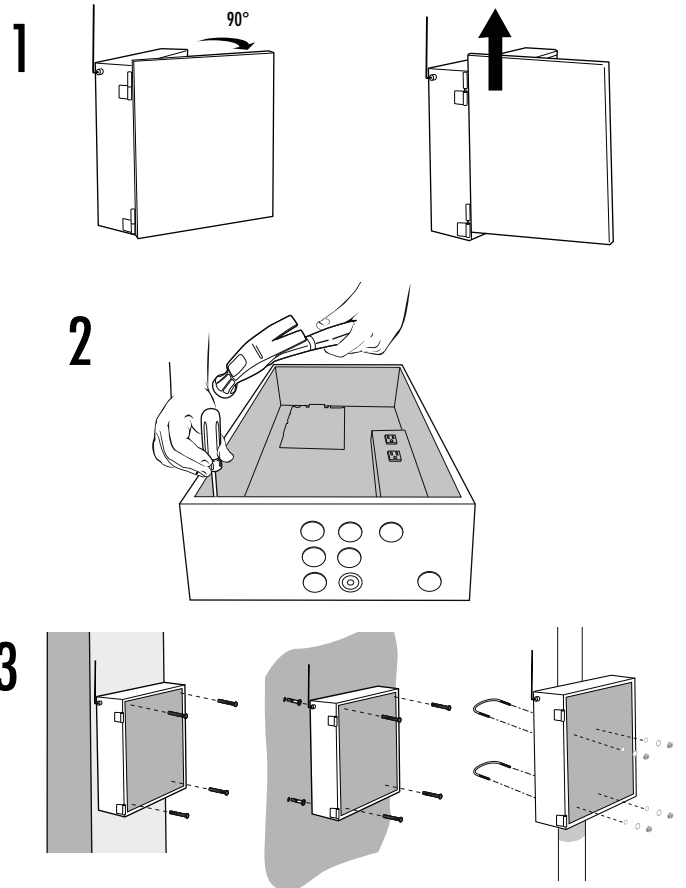

## EARTH GROUND ROD INSTALLATION (REQUIRED)

It is important to install the ground rod when using a metal control box to prevent serious injury to persons or damage to the operator.

**1** Install earth ground rod within 3 feet (0.9 m) of the operator.

**2** Connect ground rod with #12 copper wire to one of the two green ground screws inside the control box.

**NOTE:** The additional standoffs are specifically designed to mount up to 3 Chamberlain loop detectors model L07LP (not provided).

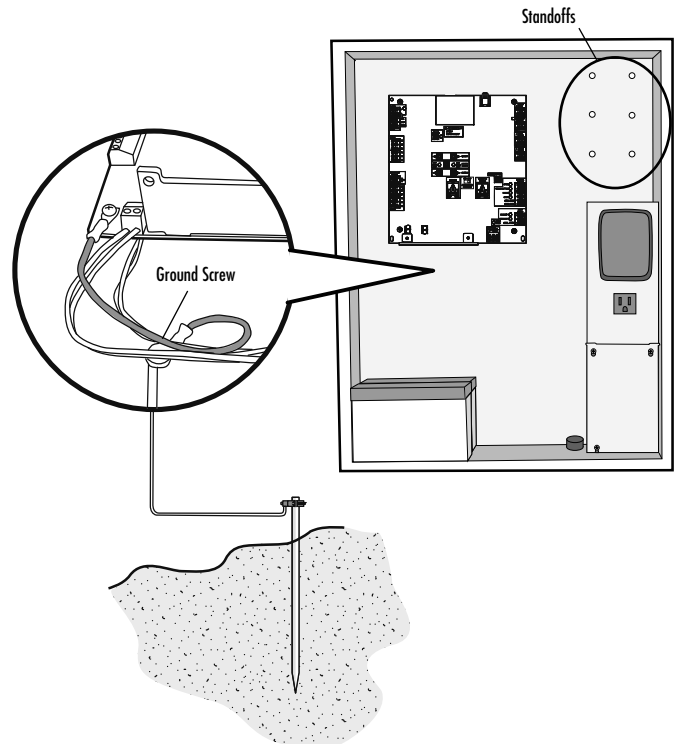

# INSTALLATION » LARGE METAL CONTROL BOX (XLM)

## WIRING

- 1 Select the knock out in the bottom of the control box based on the application requirements.
- 2 Depending on the voltage and application the 120 Vac access panel may be removed to access the wiring.
- 3 Connect two 7AH batteries, purchased separately. See Accessories page.

**IMPORTANT NOTE:** There are two receptacles located inside the control box. One of the receptacles is for the control board power supply. The second receptacle can be used to power up additional gate operator accessories.

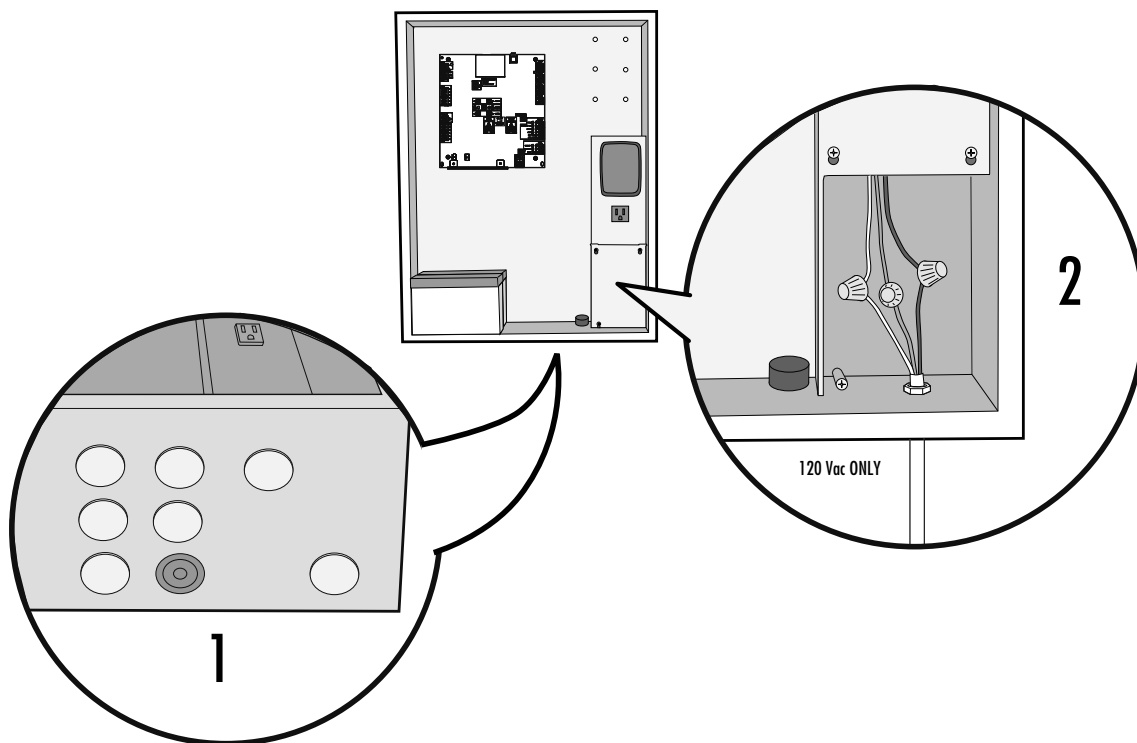

**The XLM control box wires the same as the standard control box. Follow all instructions for the standard control box. The illustrations show the standard control box, not the XLM control box.**

# WIRING » CONNECT THE GATE OPERATOR (GATE 1) TO THE CONTROL BOX

## CONNECT THE GATE OPERATOR (GATE 1) TO THE CONTROL BOX

- 1 Select hole in bottom of the control box to be used for the operator cable.
- 2 Insert the watertight connector into the bottom of the control box and tighten with nut.
- 3 Insert the operator cable through the watertight connector mounted in the bottom of the control box.
- 4 Extend the operator cable and wires to the **Gate 1** connector and connect as shown.
- 5 Tighten watertight connector nut.

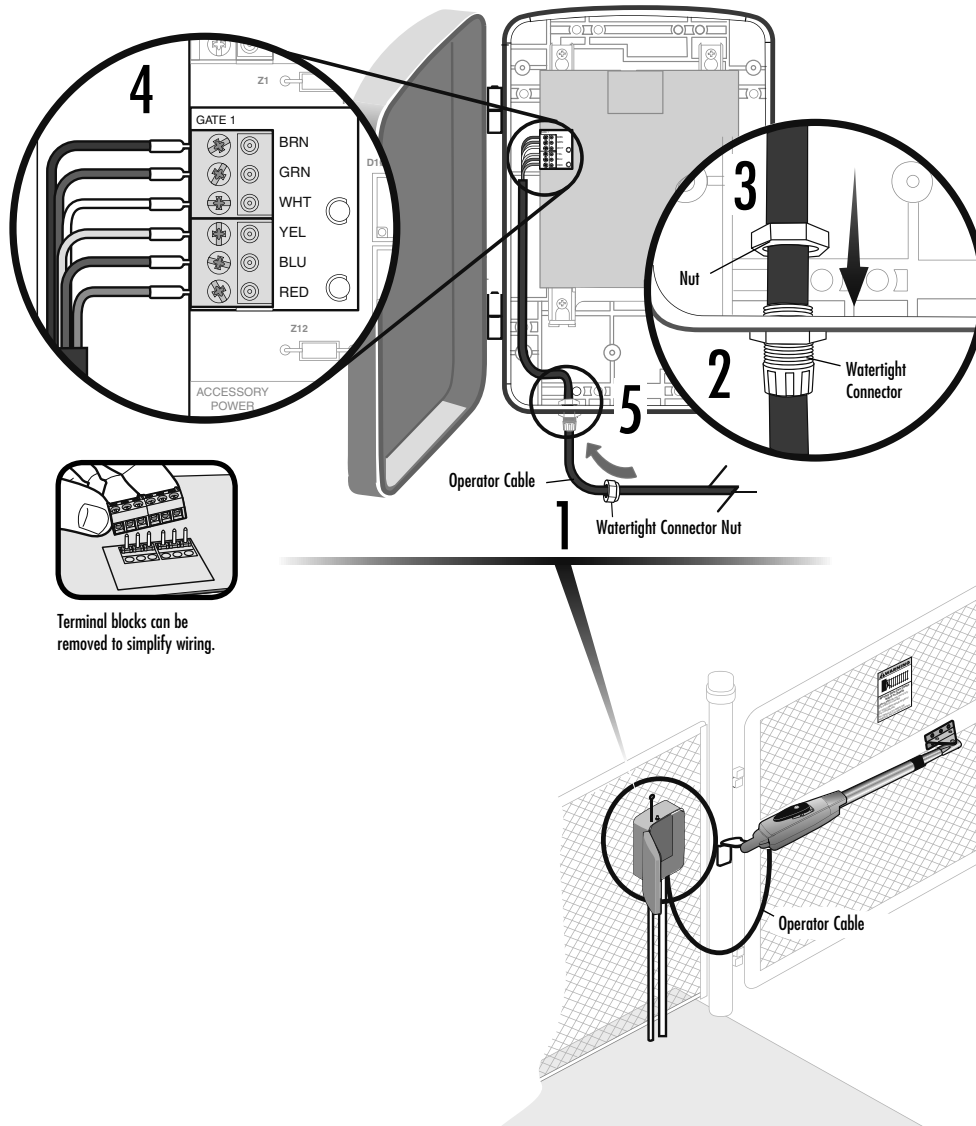

**If installing one operator, proceed to page 27.**  
**If installing two operators, continue to the next page.**

# WIRING » SET THE BIPART DELAY (MODEL LA400-S ONLY)

## SET THE BIPART DELAY (MODEL LA400-S ONLY)

In some dual gate installations, one gate will need to open first and close second. This would happen if there was an ornamental overhang on one gate or if using a solenoid lock, for example. This gate is called the Primary gate and needs to be connected to Gate 1 connections on the control board. Thus, it is preferred that the control box be installed on the same side as this gate. If there is no appropriate location on that side for the control box, then mount the control box on the opposite side, but connect the operator closest to the control box to the Gate 2 connector and the operator on the opposite side to the Gate 1 connector.

**NOTE:** The gate with the longer travel span (opening) must be set as the primary gate (GATE 1).

- 1 Set the Bipart Delay to desired setting. The range is 0 to 8 seconds, 0 seconds is OFF.

The following illustration shows a dual gate configuration with a decorative overlapping piece on the outside of the gate.

If a solenoid lock is being used on a gate, the gate with the lock attached to it is the primary gate.

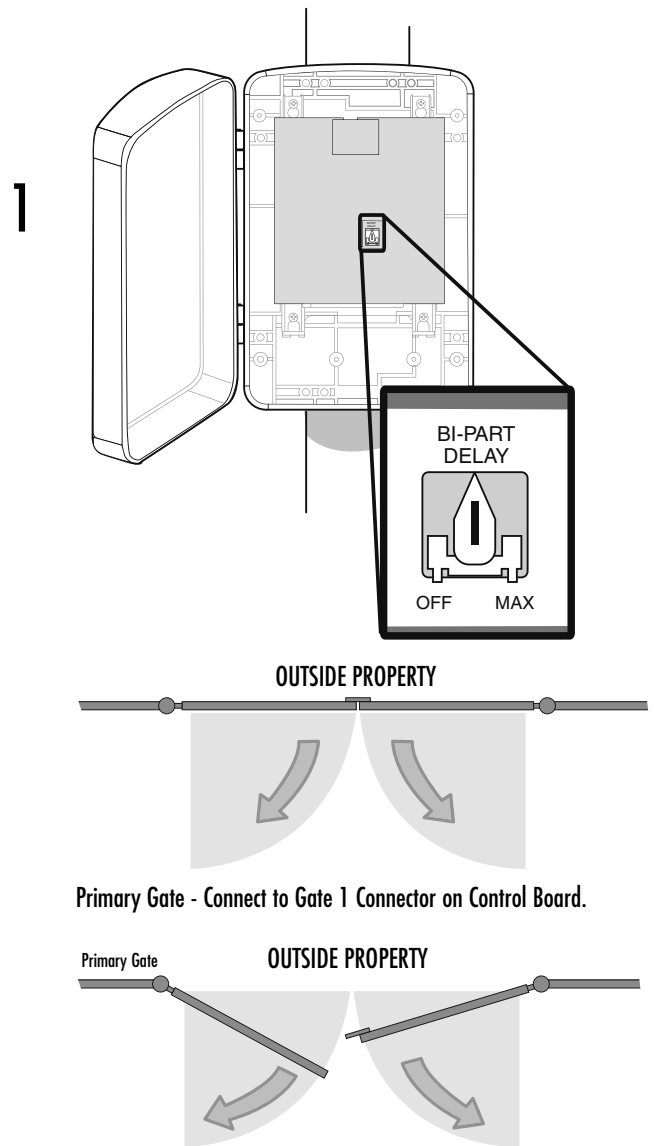



# WIRING » CONNECT THE GATE OPERATOR (GATE 2) TO THE CONTROL BOX (MODEL LA400-S ONLY)

## CONNECT THE GATE OPERATOR (GATE 2) TO THE CONTROL BOX (MODEL LA400-S ONLY)

Before digging, contact local underground utility locating companies.

- 1 Trench across driveway to bury the extension cable. Use PVC conduit to prevent damage to cables.
- 2 Select hole in bottom of the control box to be used for the extension cable. Insert extension cable through watertight connector nut and through an available watertight connector mounted in the control box.
- 3 Extend cable and wires to **Gate 2** connector and connect as shown.
- 4 Secure extension cable to control box using watertight connector nut.

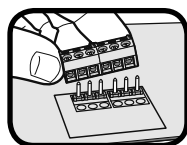
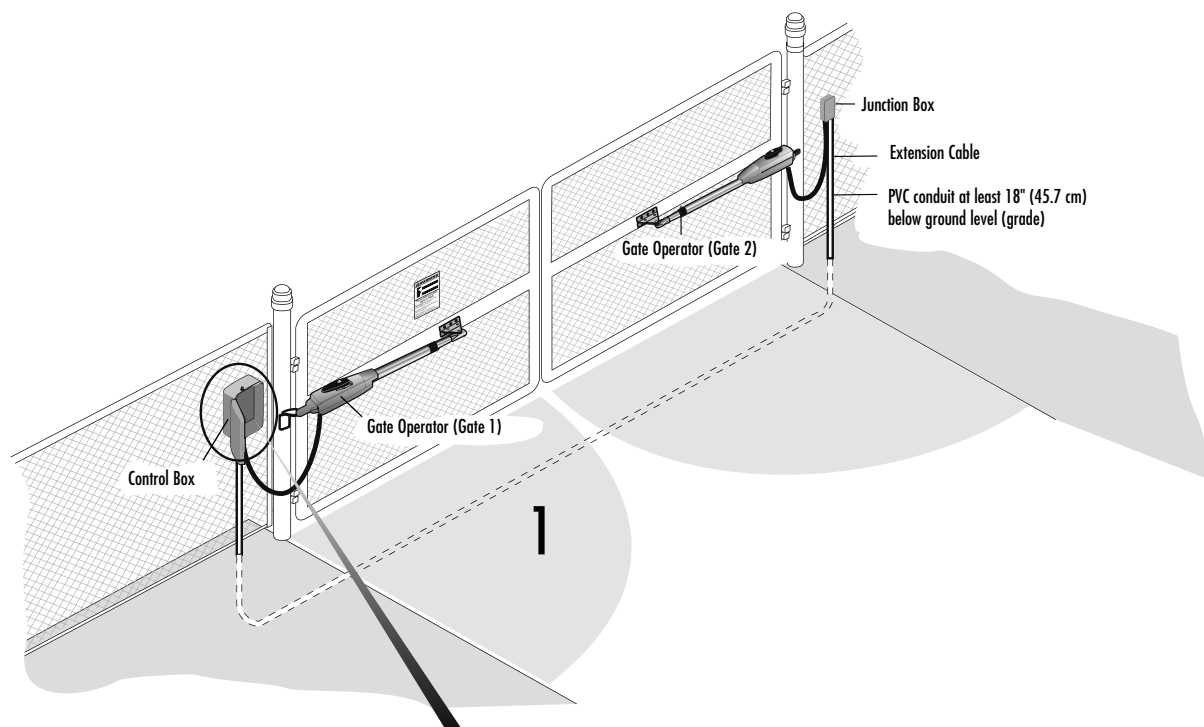

Terminal blocks can be removed to simplify wiring.

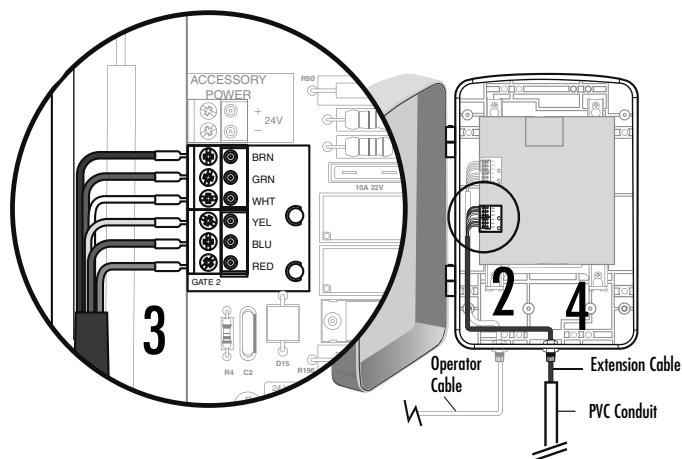

# WIRING » JUNCTION BOX (MODEL LA400-S ONLY)

## JUNCTION BOX

The following items are required to complete the junction box installation:

- 4 x 4 Junction Box with 3/4" NPT threaded port holes
- Screws
- PVC Conduit

- 1 Open the junction box by removing screws (4) and set aside.
- 2 Select holes to be used for mounting and knock out using a screwdriver and hammer. Drill two holes in the bottom of the junction box large enough for the watertight connectors.
- 3 Mount the junction box within 5 feet (1.5 m) of second operator.
- 4 Route operator cable and extension cable through watertight connector nut and watertight connector.
- 5 Insert cables and watertight connectors into the holes in the bottom of the junction box (not provided).
- 6 Secure with connector nut.

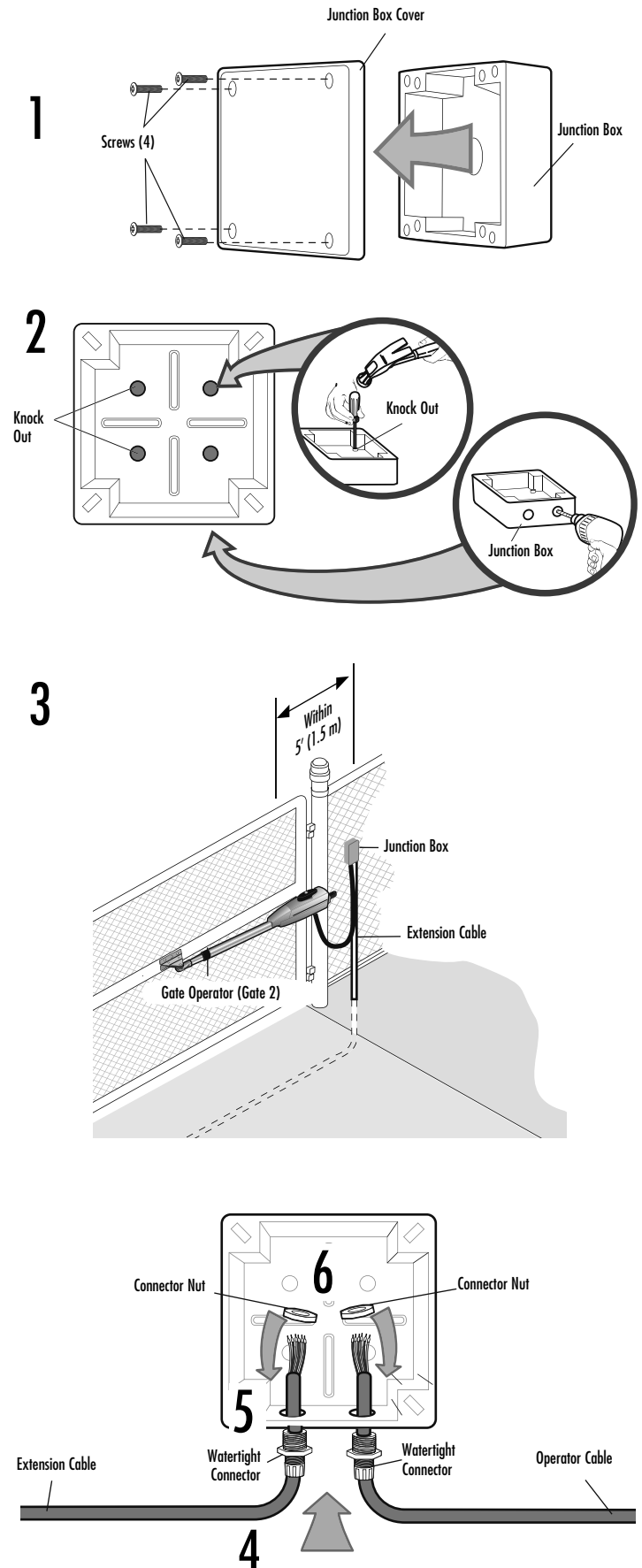

# WIRING » JUNCTION BOX (MODEL LA400-S ONLY)

- 7** Insert wires from extension cable and operator cable into terminal block connector.

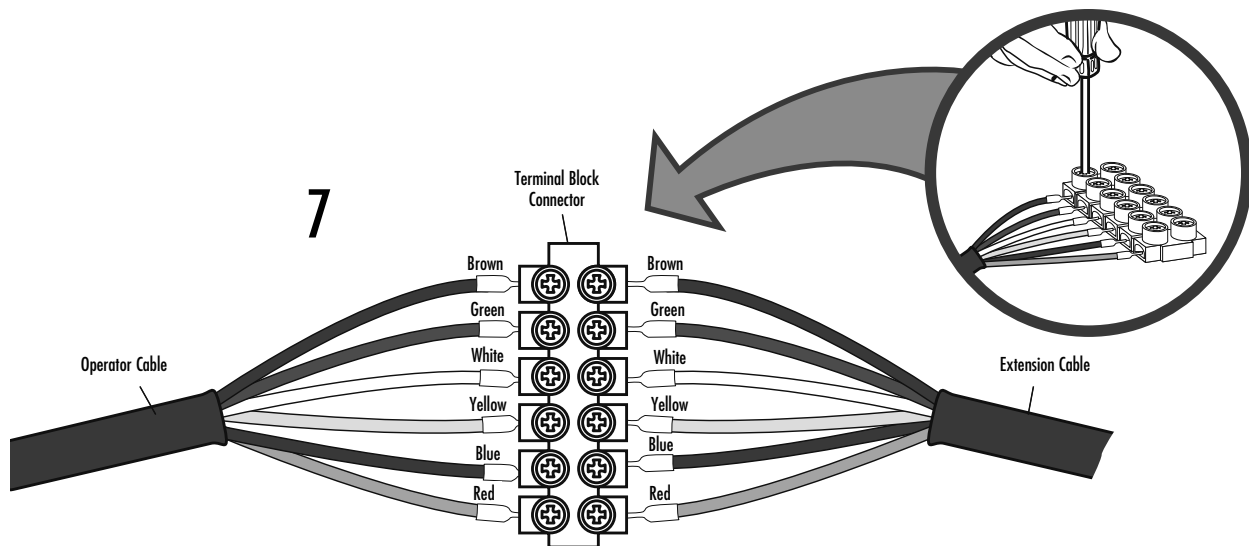

- 8** Put wires inside of junction box.

- 9** Secure operator and extension cables with watertight connector nut.

- 10** Reinstall cover.

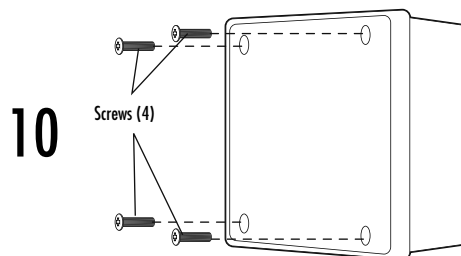
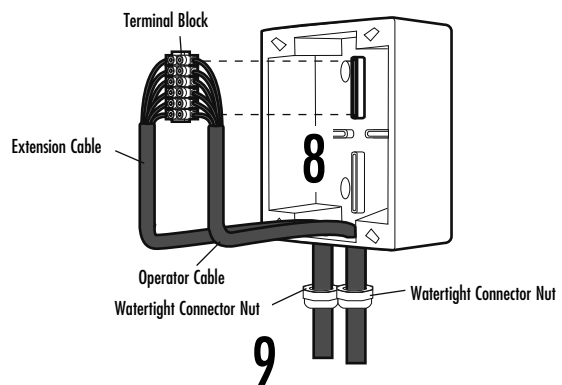

# WIRING » CONNECT TRANSFORMER TO CONTROL BOARD

## CONNECT TRANSFORMER TO CONTROL BOARD

**NOTE:** All power wiring should be on a dedicated circuit, calculated using NEC guidelines. Local codes and conditions must be reviewed for suitability of wire installation.

### EXTERNAL RECEPTACLE

**1** The transformer can be plugged into a receptacle external to the control box.

**2** Run low voltage wire between the transformer and control box.

**NOTE:** The transformer must be located in a dry location that is protected from weather conditions, such as inside the house or garage.

This will create more space in the standard control box for accessories.

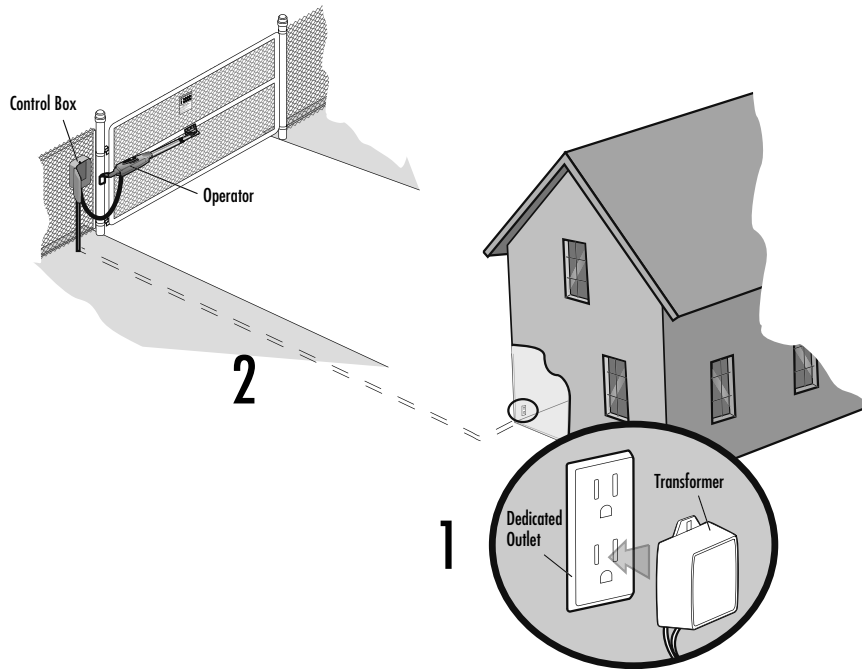

# OR

### INTERNAL RECEPTACLE

**1** Connect 120 Vac directly to the control box and plug the transformer into the receptacle inside the control box.

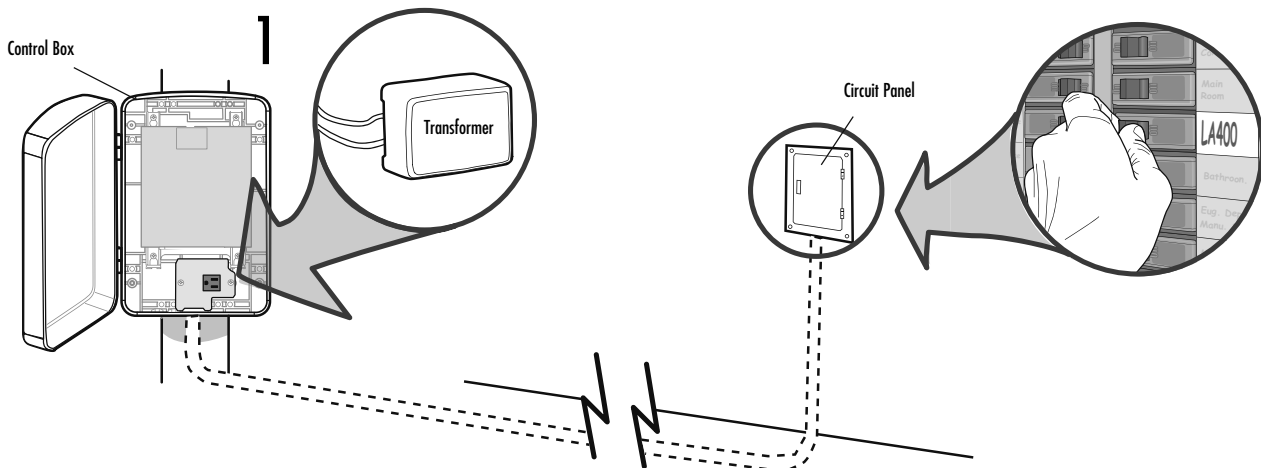

# WIRING » EARTH GROUND ROD INSTALLATION (OPTIONAL) + CONNECT BATTERIES

## EARTH GROUND ROD INSTALLATION (OPTIONAL)

**NOTE:** For proper operation, do not connect the earth ground rod to the green screw on the outlet plate.

- 1 Install earth ground rod within 3 feet (0.9 m) of the operator.
- 2 Disconnect and remove the green/yellow ground wire connected to the screw terminal of the control board.
- 3 Attach earth ground rod wire to the screw terminal of the control board marked **J4**. Ensure the power wiring ground connection remains securely connected to the green screw on the outlet plate.

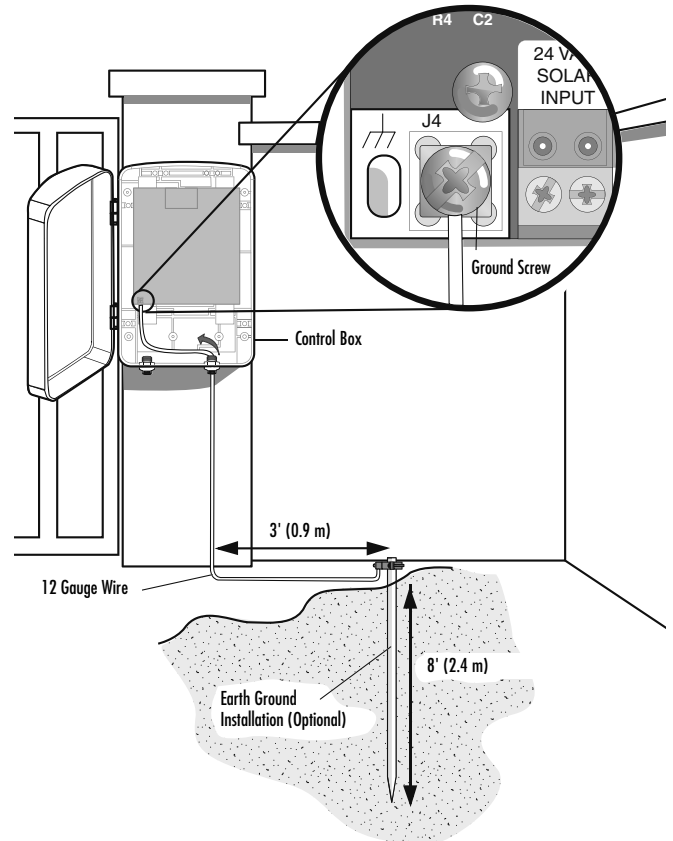

## CONNECT BATTERIES

The batteries are the main source of power for the operator. The operator is a battery run system. Both batteries are charged in circuit using the transformer (provided). The 24 Vac input can accept a charging transformer (26 Vac, 29 VA or 36 Vdc, 40 VA).

- 1 Connect the plugs from the batteries to the connectors on the control board.

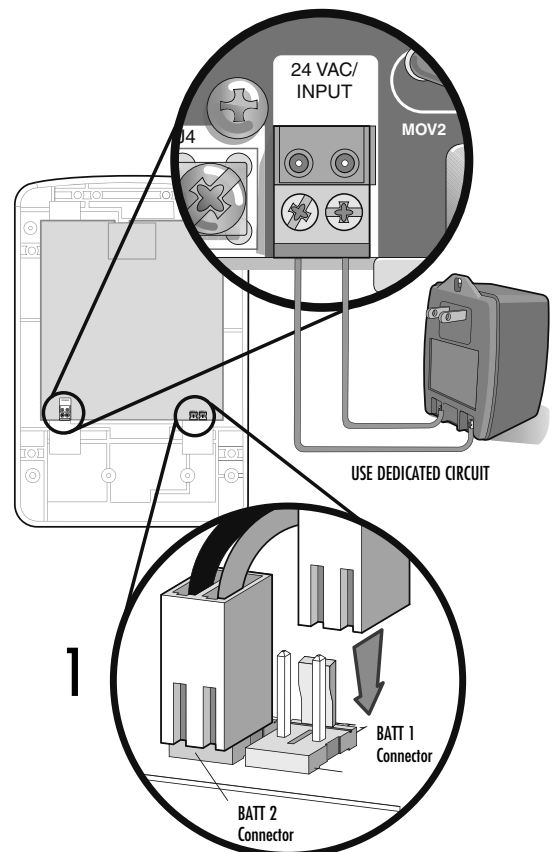

# ADJUSTMENT » SET DIP SWITCH

## SET DIP SWITCH

The Save switch must be in the OFF position prior to adjusting the switches. After the adjustments are made the Save switch must be in the ON position in order for the changes to be saved.

**1** Set the Save switch to the OFF position.

**2** Set switch to Single for single gate installation. For Dual (Gate 1 and 2) installation set switch on Dual Mode.

**3** Set the Save switch to the ON position.

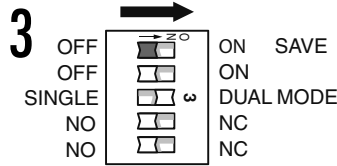
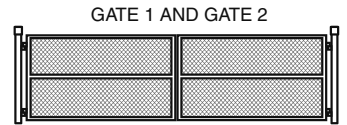
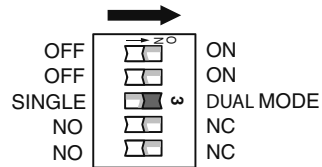
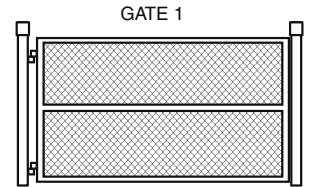
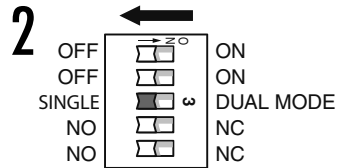
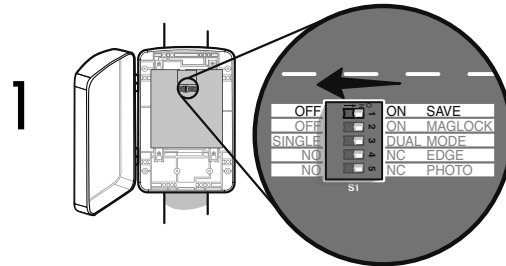

# ADJUSTMENT » LIMITS

## LIMITS

The limits are internal settings that indicate when the gates are in the fully open position and the fully closed position. For proper functionality, the limits must be programmed during the installation process. The programming uses a combination of buttons on the control board.

The specific buttons used for programming depends on which side of the gate the control box is mounted and how many operators the installation includes. Refer to pages 11 and 12 to determine if the gate is Left-handed or Right-handed.

If a mistake is made during programming press the **RESET** button on the outside of the control box to start over. The programming times-out automatically after 60 seconds of inactivity.

- 1 Close the gate.
- 2 Engage the operator by turning the release lever clockwise 180°, then turning the key clockwise 180°.

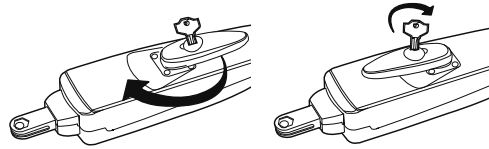

### SINGLE ARM LEFT-HAND SIDE

#### PROGRAM OPEN

- 3 Press the **LEARN LIMITS** button (SET OPEN LIMIT LED will blink).

LEARN LIMITS button

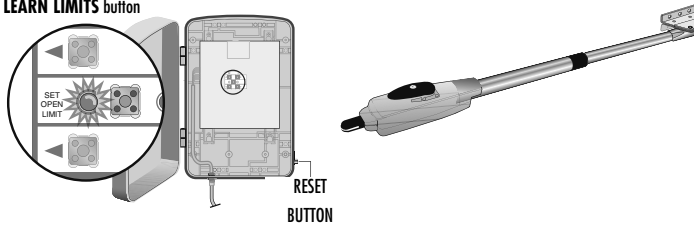

- 4 Press the **Gate 1** right button to move gate to the desired OPEN position.

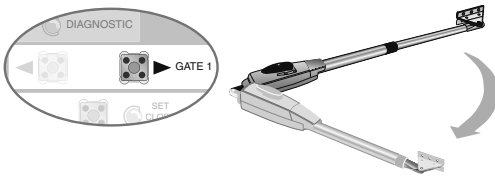

- 5 When gate is in the desired position, press the **LEARN LIMITS** button again. Control board will beep.

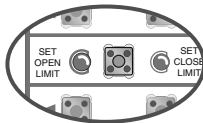

#### PROGRAM CLOSE

- 6 Press the **Gate 1** left button to move gate to the desired CLOSED position.

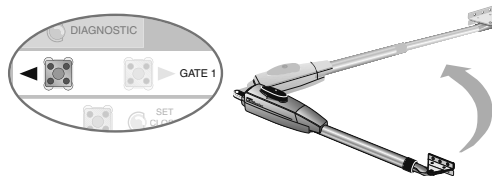

- 7 When gate is in the desired closed position, press the **LEARN LIMITS** button again.



## OR

### SINGLE ARM RIGHT-HAND SIDE

#### PROGRAM OPEN

- 3 Press the **LEARN LIMITS** button (SET OPEN LIMIT LED will blink).

LEARN LIMITS button

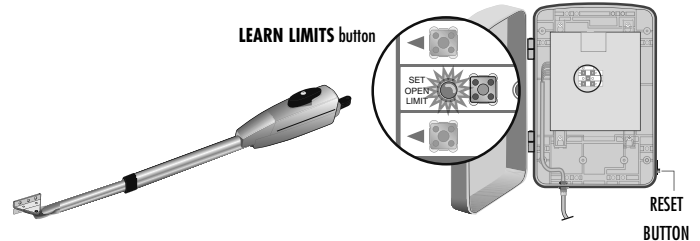

- 4 Press the **Gate 1** left button to move gate to the desired OPEN position.

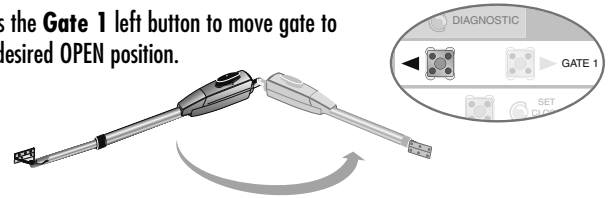

- 5 When gate is in the desired position, press the **LEARN LIMITS** button again. Control board will beep.

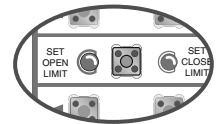

#### PROGRAM CLOSE

- 6 When the **SET CLOSE LIMIT** LED blinks, press the **Gate 1** right button.

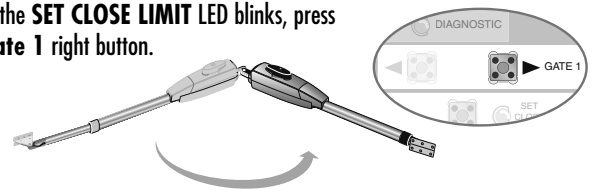

- 7 When gate is in the desired closed position, press the **LEARN LIMITS** button.



The control board beeps and the **SET OPEN LIMIT** and **SET CLOSE LIMIT** LEDs stop blinking, programming is now complete. (If the SET OPEN LIMIT LED continues to blink, repeat programming. If the problem continues, see Troubleshooting section.)

Test the limits by pressing the SBC to open and close the gate.

# ADJUSTMENT » LIMITS

## LIMITS

### NOTES:

- The gate with the longer travel span (opening) must be set as the primary gate (GATE 1).
- If one gate is overlapping the other, the gate that is overlapping must be connected to GATE 1 so it will start moving before the other gate; GATE 2 may need to be closed first if there is overlap or a gate lock is being used.
- The programming can be exited at any time by pressing the RESET button. Programming times-out automatically after 60 seconds of inactivity.

### DUAL GATE (LEFT-SIDE PRIMARY OPERATOR)

1 Close the gate.

2 Engage the operator by turning the release lever clockwise 180°, then turning the key clockwise 180°.

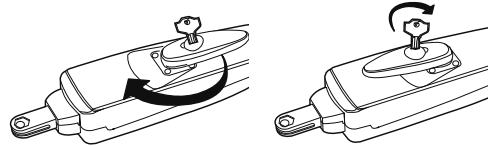

### PROGRAM OPEN

3 Press the **LEARN LIMITS** button (SET OPEN LIMIT LED will blink).

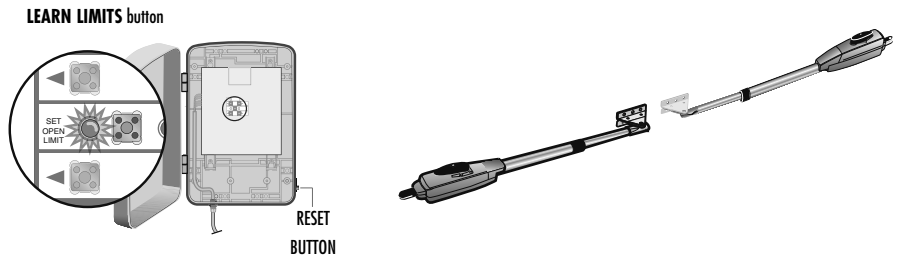

4 Press the **GATE 1** right button to open the left operator.

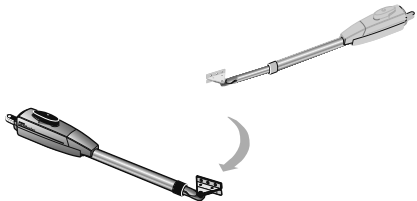

5 Press the **GATE 2** right button to move the right operator into the OPEN position.

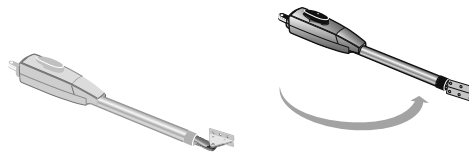

6 Press the **LEARN LIMITS** button. Control board will beep.

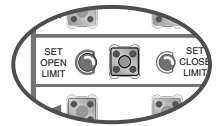

### PROGRAM CLOSE

7 When the **SET CLOSE LIMITS** LED blinks, press the **GATE 2** left button to close the right operator.

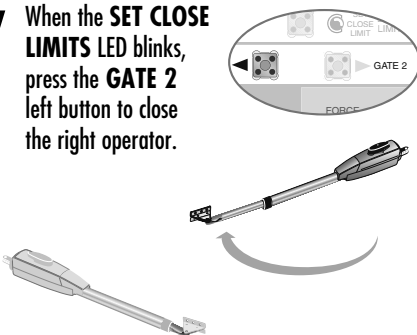

8 Press the **GATE 1** left button to close the left operator.

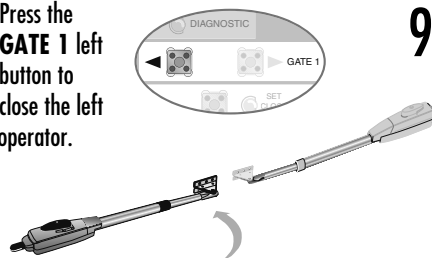

9 Press the **LEARN LIMITS** button.

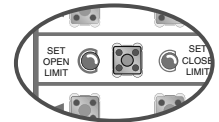

The control board beeps and the **SET OPEN LIMIT** and **SET CLOSE LIMIT** LEDs stop blinking, programming is now complete. (If the SET OPEN LIMIT LED continues to blink, repeat programming. If the problem continues, see Troubleshooting section.)

Test the limits by pressing the SBC to open and close the gate.



# ADJUSTMENT » LIMITS

## LIMITS

### NOTES:

- The gate with the longer travel span (opening) must be set as the primary gate (GATE 1).
- If one gate is overlapping the other, the gate that is overlapping must be connected to GATE 1 so it will start moving before the other gate; GATE 2 may need to be closed first if there is overlap or a gate lock is being used.
- The programming can be exited at any time by pressing the RESET button. Programming times-out automatically after 60 seconds of inactivity.

## DUAL GATE (RIGHT-SIDE PRIMARY OPERATOR)

1 Close the gate.

2 Engage the operator by turning the release lever clockwise 180°, then turning the key clockwise 180°.

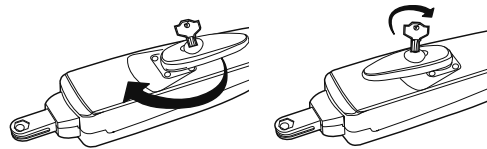

## PROGRAM OPEN

3 Press the **LEARN LIMITS** button (SET OPEN LIMIT LED will blink).

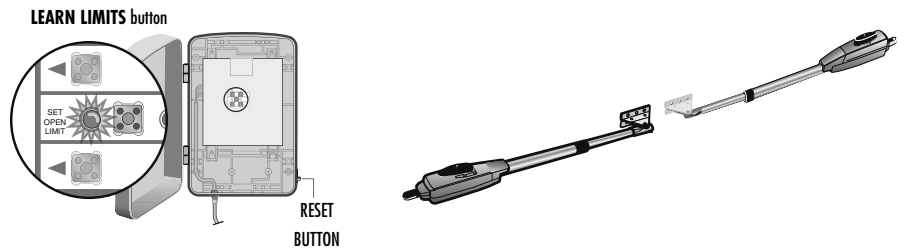

4 Press the **GATE 1** left button to open the right operator.



5 Press the **GATE 2** left button to move the left operator into the OPEN position.

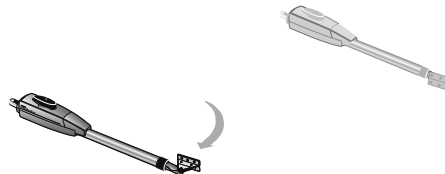

6 Press the **LEARN LIMITS** button. Control board will beep.

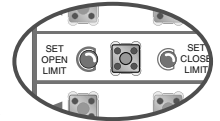

## PROGRAM CLOSE

7 When the **SET CLOSE LIMITS** LED blinks, press the **GATE 2** right button to close the left operator.

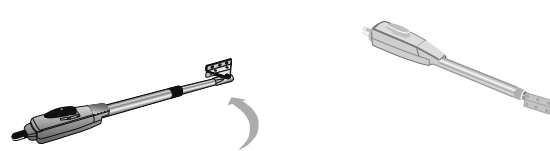
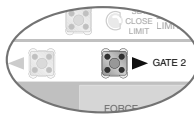

8 Press the **GATE 1** right button to close the right operator.

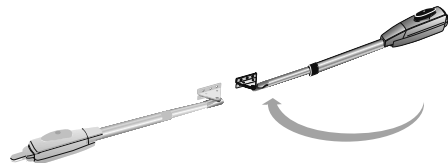

9 Press the **LEARN LIMITS** button.

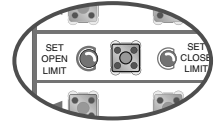

The control board beeps and the **SET OPEN LIMIT** and **SET CLOSE LIMIT** LEDs stop blinking, programming is now complete. (If the SET OPEN LIMIT LED continues to blink, repeat programming. If the problem continues, see Troubleshooting section.)

Test the limits by pressing the SBC to open and close the gate.

# ADJUSTMENT » FORCE ADJUSTMENT + TIMER-TO-CLOSE (TTC)

## ⚠ WARNING

Without a properly installed safety reversal system, persons (particularly small children) could be **SERIOUSLY INJURED** or **KILLED** by a closing gate.

- Too much force on gate will interfere with proper operation of safety reversal system.
- **NEVER** increase force beyond minimum amount required to close gate.
- **NEVER** use force adjustments to compensate for a binding or sticking gate.
- If one control (force or travel limits) is adjusted, the other control may also need adjustment.
- After **ANY** adjustments are made, the safety reversal system **MUST** be tested. Gate **MUST** reverse on contact with a rigid object.

### FORCE ADJUSTMENT

The operator is equipped with an obstruction current sensing feature. If the gate encounters an obstruction the operator will automatically reverse direction and stop. Based on the length and weight of the gate it may be necessary to make force adjustments. The force adjustment should be high enough that small objects such as branches or wind will not cause nuisance interruptions but low enough to prevent serious injury to a person or a vehicle.

#### TO ADJUST THE FORCE

- 1 Using the 3-button remote or the Single Button Control (SBC) button on the control board, open and then close the gate.
- 2 If the gate stops or reverses before reaching the fully open or closed position increase the force by turning the force control slightly.
- 3 Run operator through a complete cycle.
- 4 Test the force by making sure the gate will stop and reverse on contact with an obstruction.

**NOTE:** Weather conditions can affect the gate movement, so seasonal adjustment may be required. The force control is factory set to the mid position.

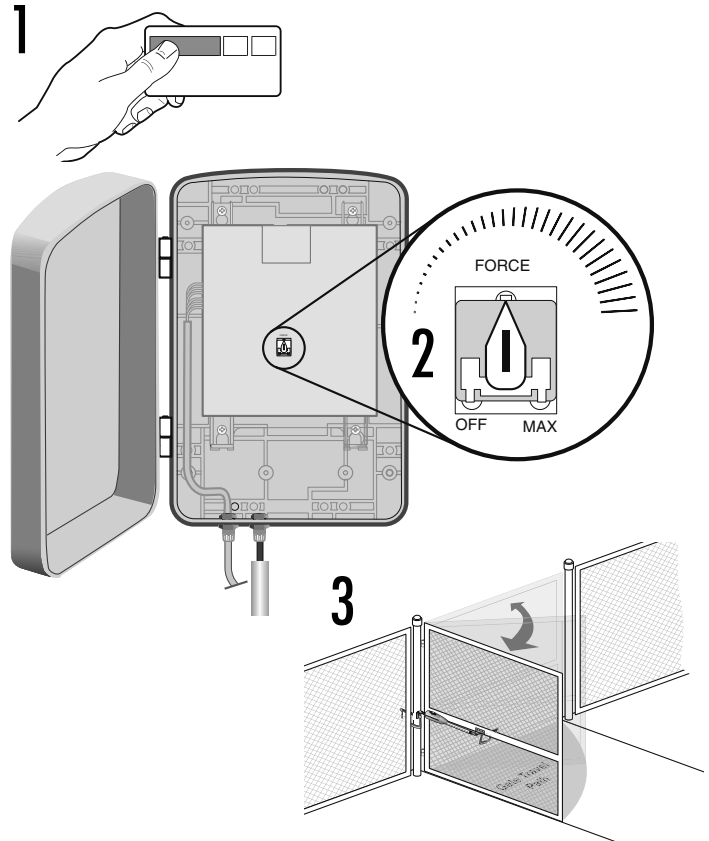

### TIMER-TO-CLOSE (TTC)

The Timer-to-Close feature can be set to automatically close the gate after a specified time period. The TTC is factory set to OFF.

If the TTC is set to the OFF position, then the gate will remain open until the operator receives another command from a remote control or SBC. The gate must be fully open for the timer feature to activate and close the gate.

#### TO SET THE TIMER-TO-CLOSE

- 1 Rotate the Timer-to-Close dial to the desired setting. The range is 0 to 180 seconds, 0 seconds is OFF. The "TIMER RUNNING LED" will flash once for every second of adjusted time.

**NOTE:** Any radio command, SBC or CLOSE command on the control board prior to the TTC expiring will close the gate. The TTC is reset by any signals from the loops, close edges and close photoelectric sensors (IR's).

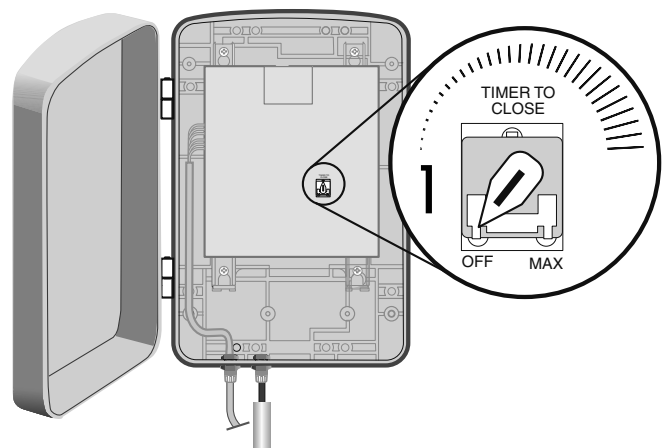

# PROGRAMMING » REMOTE CONTROLS + KEYLESS ENTRY + ERASE ALL CODES + TEST

A combined total of 50 remote controls and keyless entry PIN can be programmed to the operator. For highest level of security, we recommend the Security+® line of products. Refer to Accessories.

## TO ADD OR REPROGRAM A REMOTE CONTROL (NOT PROVIDED)

- 1 Press LEARN XMITTER button and release (LED will light up).
- 2 Press the remote control button. The LED will flash and the alarm output will activate twice.

To program additional remote controls, repeat steps until all remote controls are programmed.

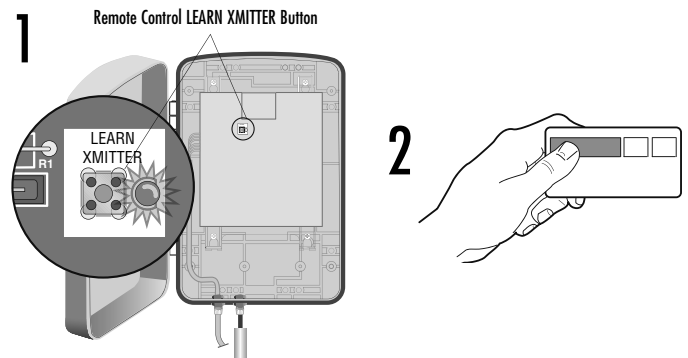

## TO ADD A WIRELESS KEYLESS ENTRY (NOT PROVIDED)

- 1 Press LEARN XMITTER button and release (LED will light up).
- 2 Enter a 4-digit personal identification number (PIN) of your choice on the keypad.
- 3 Press the ENTER button on the keypad. The LED will flash and the alarm output will activate twice.

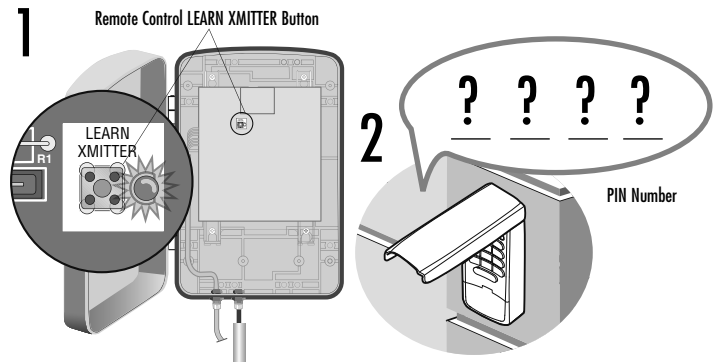

## TO ERASE ALL CODES

- 1 Press and hold the LEARN XMITTER button on control board until the learn indicator light goes out (approximately 6 seconds). All previous codes are now erased.

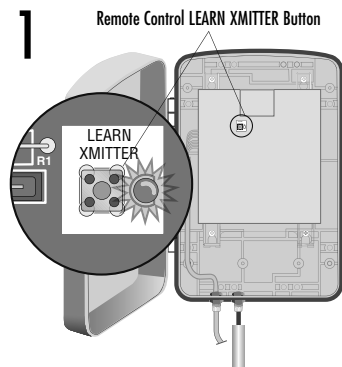

NOTICE: To comply with FCC and or Industry Canada (IC) rules, adjustment or modifications of this receiver and/or transmitter are prohibited, except for changing the code setting or replacing the battery. THERE ARE NO OTHER USER SERVICEABLE PARTS.

Tested to Comply with FCC Standards FOR HOME OR OFFICE USE. Operation is subject to the following two conditions: (1) this device may not cause harmful interference, and (2) this device must accept any interference received, including interference that may cause undesired operation.

## TEST

After any adjustments are made, test the operator:

- 1 Use the Single Button Control (SBC) button to open and close the gate.
- 2 Test the limits by making sure the gate is stopping at the OPEN and CLOSE limits.
- 3 Test the force by making sure the gate will stop and reverse on contact with an obstruction.

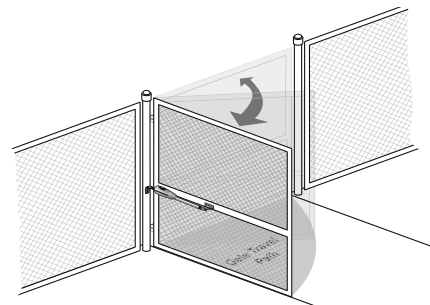

# ADDITIONAL FEATURES » DIP SWITCH SETTINGS

## DIP SWITCH SETTINGS

The Save switch must be in the OFF position prior to adjusting the switches. After the adjustments are made the Save switch must be in the ON position in order for the changes to be saved.

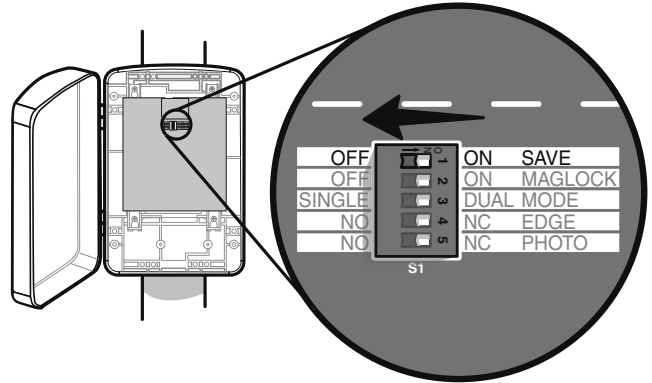

### A SAVE SWITCH S1-1

This switch (S1-1) is used to save the settings for switches 2 through 5.

### B MAG DELAY ENABLE

This switch (S1-2) enables the Maglock feature. On an open command there will be a 1/2 second delay before the motor starts, to allow the Maglock to release.

### C MODE DUAL/SINGLE

This switch (S1-3) sets the mode as Dual or Single (Refer to page 29).

### D SAFETY INPUTS

Swing gates allow four safety inputs. A DIP switch is required for determining between N/O and N/C edges and N/O and N/C eyes.

#### EDGE INPUT

Set switch (S1-4) to the following settings:

N/O Edge (Active Close) = N/O dry contact edge or monitored edge

**NOTE:** Monitored Edges should be set in the N/O position, as the activation condition is shorting the terminals.

#### EYE INPUT

This switch (S1-5) differentiates between N/O and N/C dry contact photoelectric eye inputs.

**NOTE:** Pulsing Chamberlain (CPS-L) photoelectric eyes will automatically learn in N/O mode (See Accessories).

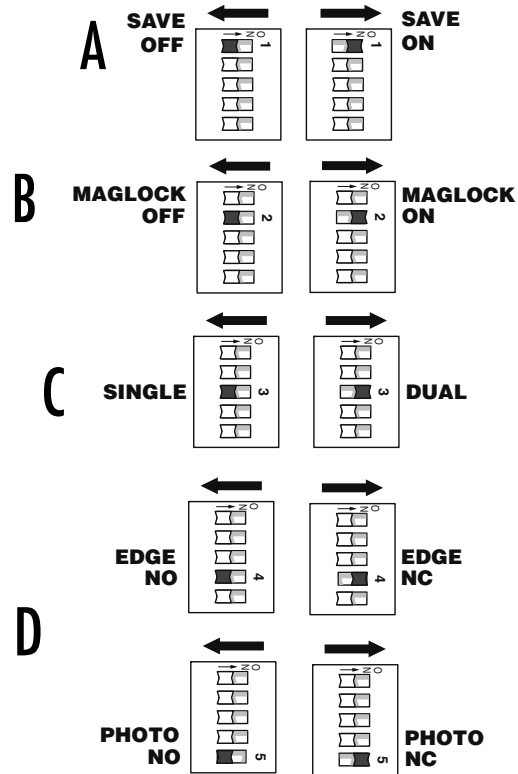

# ADDITIONAL FEATURES » CONTROL INPUTS

## CONTROL INPUTS

### WIRE STOP BUTTON (OPTIONAL)

A jumper wire is factory installed between the stop and common input.

**Stop (N/C)** - Stop only (does not reset alarm).

**NOTE:** Stop jumper is required for normal operation (the Stop LED will be lit except when the control board goes into Sleep Mode). Remove only if remotely mounted Stop button is added.

### OPEN

Opens only or reverses a closing gate.

### SBC (SINGLE BUTTON CONTROL) INPUT

This input will command the gate to OPEN / STOP / CLOSE / STOP in sequence.

### RESET CONTROL INPUT

The control box has a factory installed internal reset button. These terminals are intended for use with a single reset button that is installed within line of sight of the gate. This input functions to reset the alarms. This input will NOT stop the gate.

**NOTE:** All Control Inputs must be Normally Open (N.O.) dry contact type.

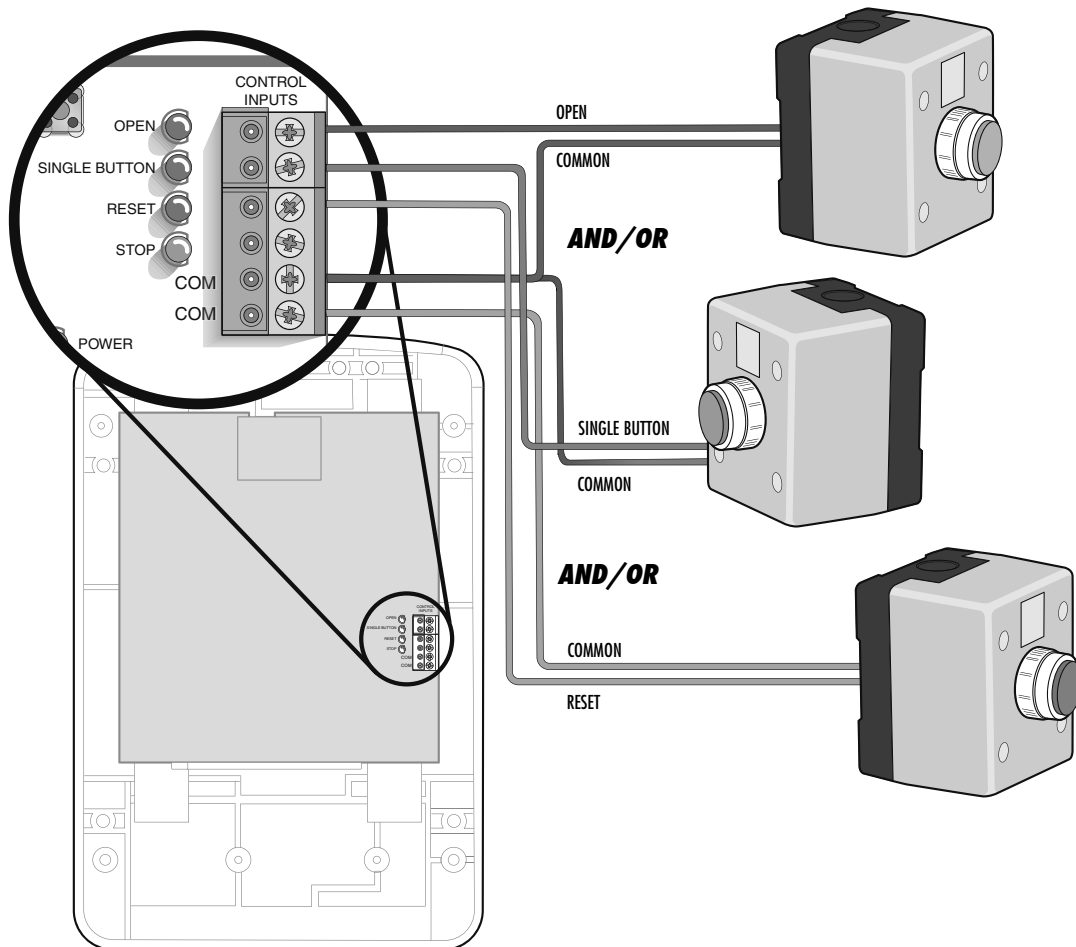
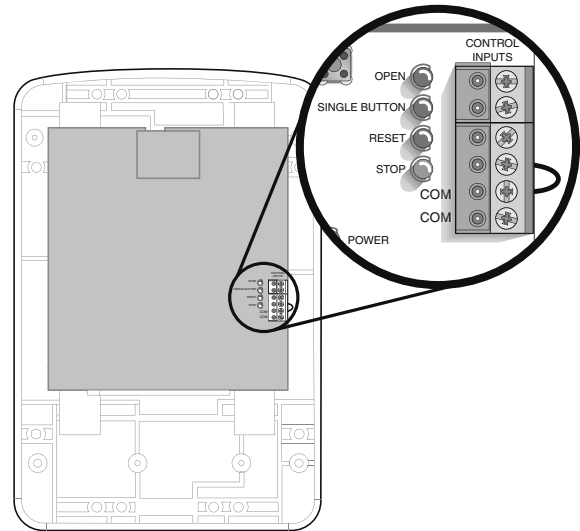

# ADDITIONAL FEATURES » LOOP INPUTS + PHOTO/EDGE INPUTS (P6-7-8 AND 9)

## LOOP INPUTS

### OPEN INPUT AND EXIT LOOP

These terminals are intended for use as a general open control. Accessories such as telephone entry systems, radio receivers (open only applications), exit loop detectors, keypads and 7-day timers may be wired to this input.

### SHADOW LOOP INPUT TERMINAL AND COMMON

This input protects cars by preventing the gate from moving off of the open or close limit when the shadow loop input is active.

**NOTE:** Shadow loop is disabled when gate is moving.

### INTERRUPT LOOP INPUT TERMINAL AND COMMON

This input functions to reverse a closing gate to the open limit. Latching this input will reset the timer to close.

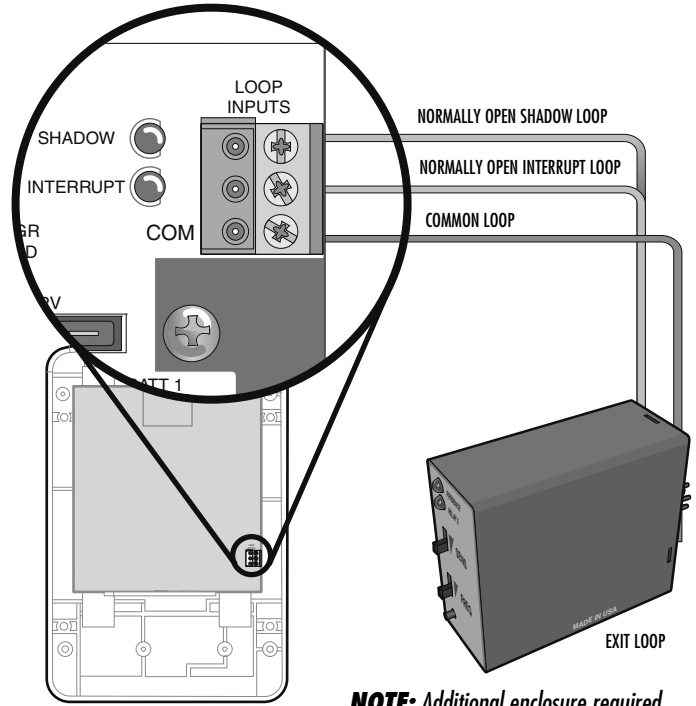

**NOTE:** Additional enclosure required. Refer to loop detector manufacturer instructions for connections.

## PHOTO/EDGE INPUTS (P6-7-8 AND 9)

### TERMINAL P6 – CLOSE SAFETY EDGE

This input will reverse a closing gate. It will disable the Timer-to-Close if that feature has been enabled. Activating this input while the gate is opening will have no effect. Order part number LA400-BOX to enclose safety electronics.

### TERMINAL P8 – OPEN SAFETY EDGE/PHOTOELECTRIC SENSOR (ENTRAPMENT)

If an Open Edge device or a Retro-Reflective Photoelectric Sensor has been connected to Terminal P8, then this input will reverse an opening gate for 2 seconds then stop. Activating this input with an Open Edge device or a Retro-Reflective Photoelectric Sensor connected to Terminal P8 while the gate is closing will have no effect.

If a Chamberlain Pulsing Photoelectric Sensor (See Accessories) has been connected to Terminal P8, then this input will pause an opening gate until the obstruction has been removed. Upon removing the obstruction, the gate will continue to open. Activating this input with a Chamberlain Pulsing Photoelectric Sensor (See Accessories) connected to Terminal P8 while the gate is closing will have no effect.

### TERMINAL P7 – OPEN SAFETY PHOTOELECTRIC SENSOR (ENTRAPMENT)

This input will pause an opening gate until the obstruction has been removed. Upon removing the obstruction, the gate will continue to open. Activating this input while the gate is closing will have no effect.

### TERMINAL P9 – CLOSE SAFETY PHOTOELECTRIC SENSOR

This input will reverse a closing gate to the open limit. Activating this input while the gate is opening will have no effect. The Timer-to-Close will reactivate at the open limit.

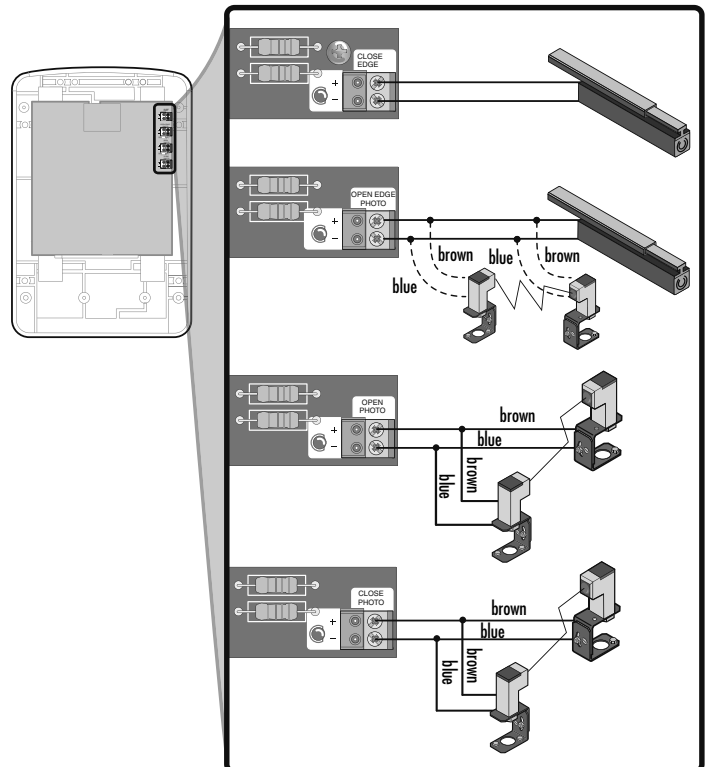

# ADDITIONAL FEATURES » SAFETY ACCESSORIES FOR SECONDARY ENTRAPMENT PROTECTION

## SAFETY ACCESSORIES FOR SECONDARY ENTRAPMENT PROTECTION

The following devices are acceptable for Safety Accessories for secondary entrapment protection. These devices have been tested with the LA400 to meet the requirements of UL325 and UL991.

PHOTOELECTRIC CONTROLS		
MODEL	DESCRIPTION	VOLTAGE
CPS-LN4	Emitter, receiver and mounting brackets - 30 feet (9 m) Ranges	+24 Vdc
CPS-RN4	Emitter with reflector and mounting brackets	+24 Vdc
SENSING EDGES		
MODEL	DESCRIPTION	
G65MG0204	Miller MG020 2-wire electric edge for gates. Sensitized on three sides. (Requires mounting channel. PIN:G65ME120C5)	
G65MG0205	Miller MG020 2-wire electric edge for gates. Sensitized on three sides. (Requires mounting channel. PIN:G65ME120C5)	
G65MGR205	Miller MGR20 2-wire electric edge in 5 feet (1.5 m) lengths for 2 inch (5 cm) round post.	
G65MGS205	Miller MGR20 2-wire electric edge in 5 feet (1.5 m) lengths for 2 inch (5 cm) square post.	

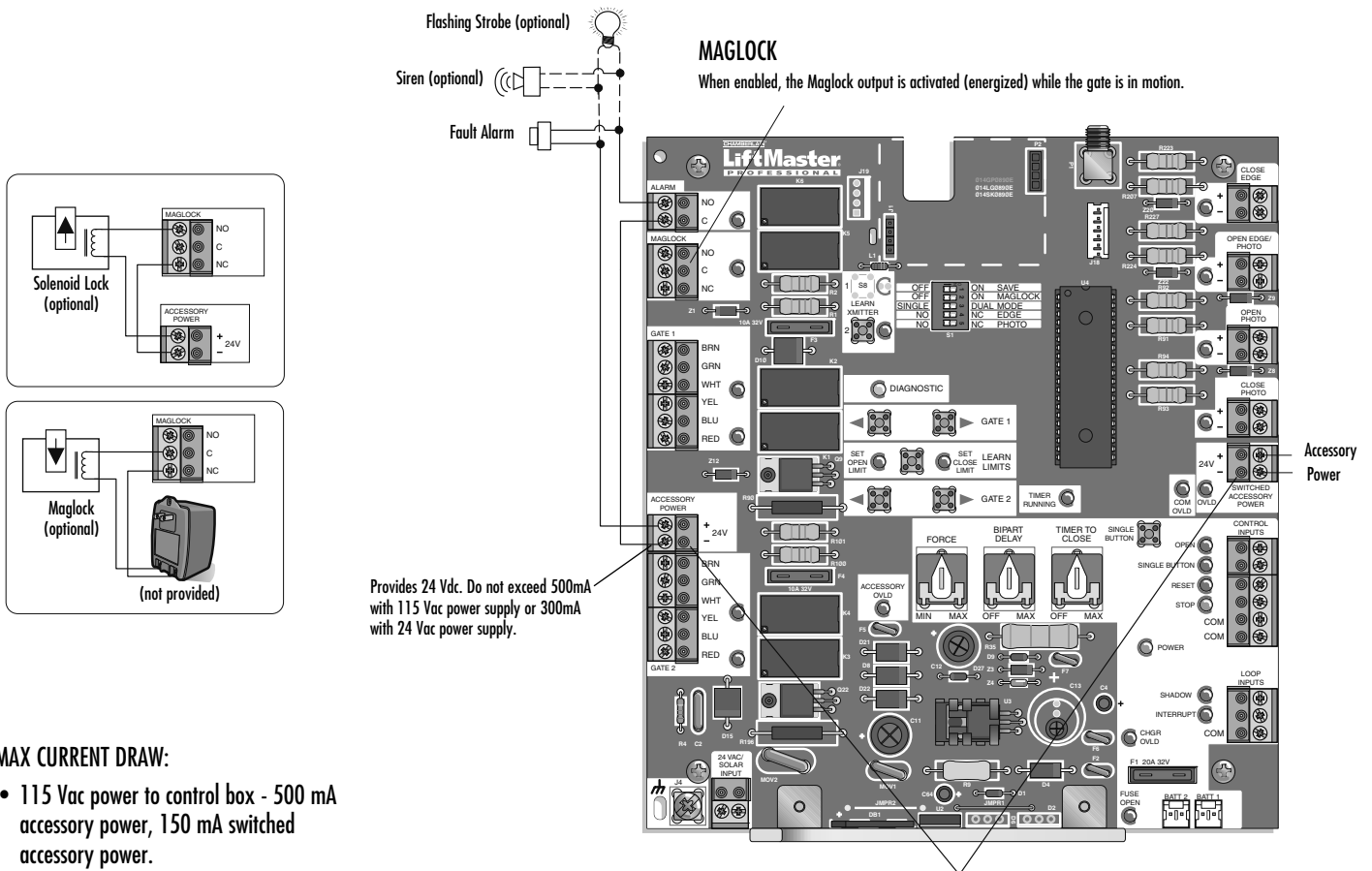

**AUXILIARY OUTPUT POWER FOR OPTIONAL DEVICES**  
(2) +24 Vdc Outputs have been provided for optional devices

- MAX CURRENT DRAW:**
- 115 Vac power to control box - 500 mA accessory power, 150 mA switched accessory power.
  - 24 V power to control box depending on wire gauge and distance - 300 mA accessory power, 75 mA switched accessory power.

**Make sure the rubber seal around the cover is intact and close the cover. Secure the control box cover with screws (4). Installation is complete.**

# OPERATION AND MAINTENANCE » RESET BUTTON + REMOTE CONTROL + MANUAL RELEASE

## RESET BUTTON

The reset button is located on the outside of the control box and serves several functions.

### PROGRAMMING LIMITS RESET

If a mistake is made while programming the limits press the reset button to start over.

### OPERATOR ALARM

The operator alarm will sound under the following condition: If gate encounters two consecutive obstructions, before reaching the open or close limit, the operator will stop, the alarm will sound (up to 5 minutes) and the control board will require resetting. No commands will operate the gate during this time. Reset the control board by pressing the reset button. After the operator is reset, normal functions will resume.

### PARTY MODE (TIMER DEFEAT - HOLD OPEN)

When the Timer-to-Close feature is activated for normal daily operation and you wish to leave the gate(s) in the open position for any extended period of time you can activate the Party Mode.

To set Party Mode: open the gate fully, then press the reset button. The next command given by remote control or SBC on the control board will close the gate and return the operator to normal operation.

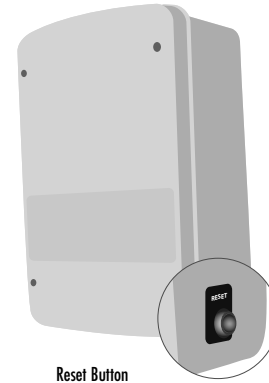

Reset Button

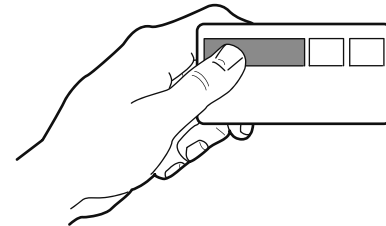

## REMOTE CONTROL

Once the remote control has been programmed operator will operate as follows:

When gate is in the closed position, activation of the remote control button will open the gate. During the open cycle another activation of the remote control will stop the gate and the next activation of the remote control will close the gate.

When the gate is in the open position, activation of the remote control button will close the gate.

## MANUAL RELEASE

In case of a power failure, the operator can be disengaged from the gate. With an operator, the release action may sometimes feel stiff/jerky, which is normal and has no effect on function.

### RELEASE

- 1 Insert the key into the lock.
- 2 Turn the key counter-clockwise 180°.
- 3 Turn the release lever counter-clockwise 180°.

Operator is in manual mode and the gate can be opened and closed manually.

### ENGAGE

- 1 Turn the release lever clockwise 180°. This engages the motor.
- 2 Turn the key clockwise 180°. This locks the release lever.
- 3 Remove the key and store in a safe place.

The operator is now engaged.

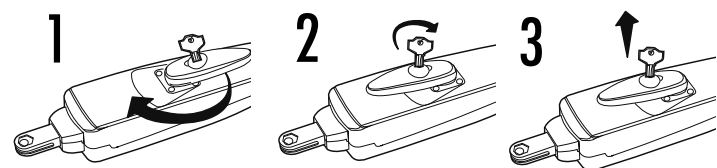
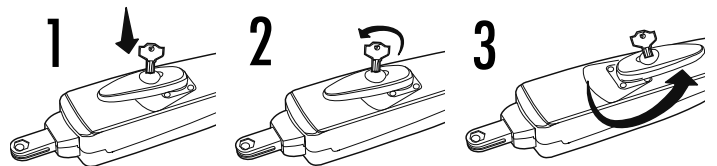



# OPERATION AND MAINTENANCE » MAINTENANCE

## MAINTENANCE

Disconnect power before servicing.

<b>DESCRIPTION</b>	<b>TASK</b>	<b>MONTH</b>	<b>CHECK AT LEAST ONCE EVERY</b>	
			<b>6 MONTHS</b>	<b>3 YEARS</b>
External Entrapment Protection System	Check and test for proper operation	X		
Manual Release	Check and test for proper operation		X	
Gate	Inspect for wear or damage	X		
Accessories	Check all for proper operation		X	
Electrical	Inspect all wire connections		X	
Mounting Hardware	Check for tightness		X	
Batteries	Replace			X
Operator	Inspect for wear or damage		X	
Warning Signs	Make sure they are present	X		

### NOTES:

- Severe or high cycle usage will require more frequent maintenance checks.
- Inspection and service should always be performed anytime a malfunction is observed or suspected.
- When servicing, please do some "house cleaning" of the operator and the area around the operator. Pick up any debris in the area. Clean the operator as needed.
- It is suggested that while at the site voltage readings be taken at the operator. Using a Digital Voltmeter, verify that the incoming voltage to the operator it is within ten percent of the operator's rating.
- See page 33 for instructions on how to adjust the gate force.

# TROUBLESHOOTING » BASIC CONTROL BOARD LAYOUT

## BASIC CONTROL BOARD LAYOUT

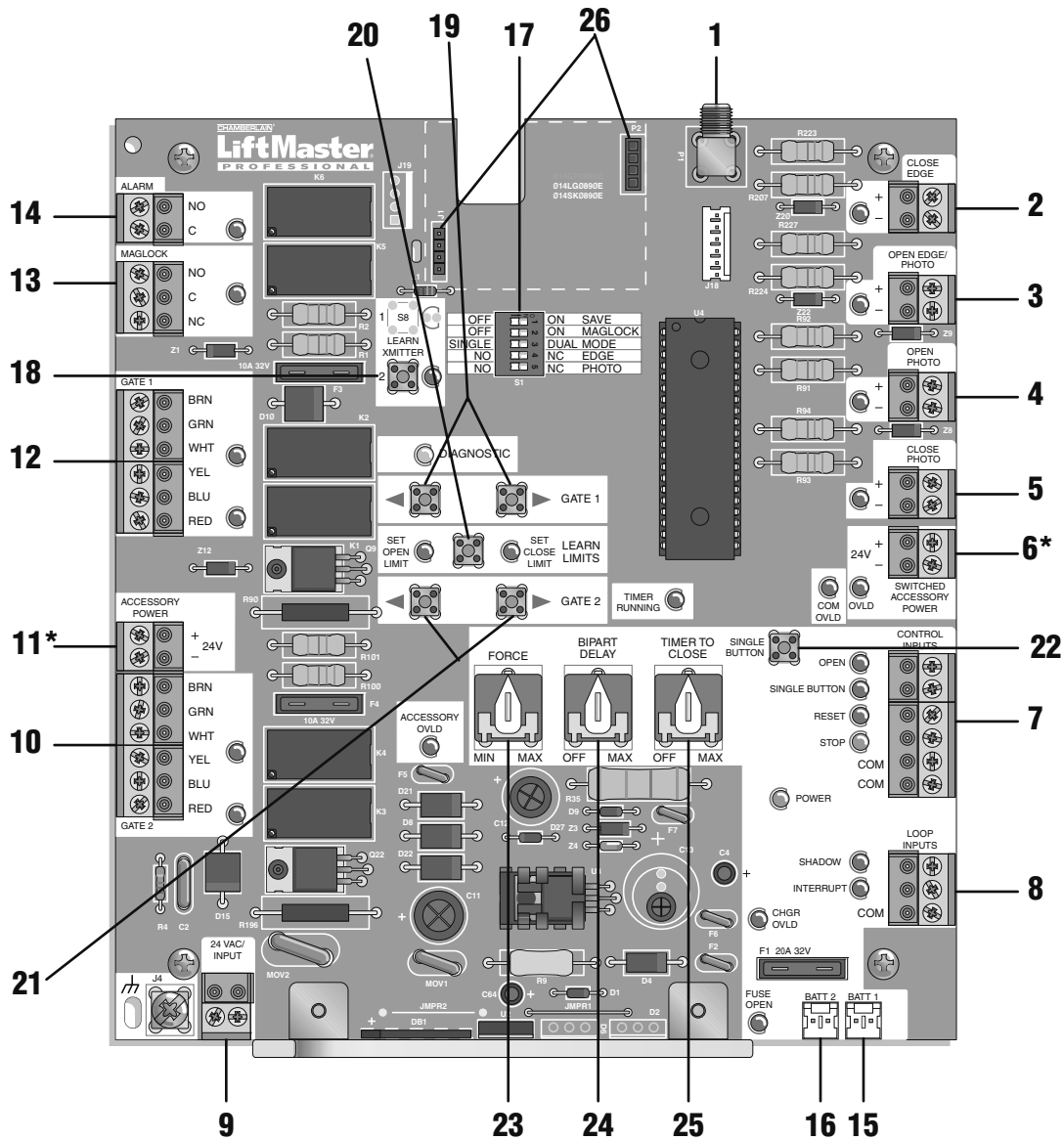

ITEM	DESCRIPTION	FUNCTION	ITEM	DESCRIPTION	FUNCTION
1	Connector P1	Antenna Input	14	Connector P15	Alarm
2	Connector P6	Close Edge	15	Connector	Battery 1
3	Connector P8	Open Edge/Photo	16	Connector	Battery 2
4	Connector P7	Open Photo	17	DIP Switch	S1
5	Connector P9	Close Photo	18	Pushbutton	Learn Xmitter - Program Remote
6	Connector P12	Switched Accessory Power*	19	Pushbuttons	Gate 1 - Jag Learn Limit
7	Connector P10	Control Inputs	20	Pushbutton	Learn Limits
8	Connector P11	Loop Inputs	21	Pushbuttons	Gate 2 - Jag Learn Limit
9	Connector P5	24 Vac Input	22	Pushbutton	Single Button
10	Connector P16	Gate 2	23	Potentiometer	Force
11	Connector P13	Accessory Power*	24	Potentiometer	Bipart Delay
12	Connector P17	Gate 1	25	Potentiometer	Timer-to-Close
13	Connector P14	Maglock/Solenoid	26	Connector	Receiver

\*See page 38 for max current draw

# TROUBLESHOOTING » WIRING DIAGRAM + DIAGNOSTIC CODES

## ⚡ WARNING

To protect against fire and electrocution:

- DISCONNECT power and battery BEFORE installing or servicing operator.

For continued protection against fire:

- Replace ONLY with fuse of same type and rating.

### WIRING DIAGRAM

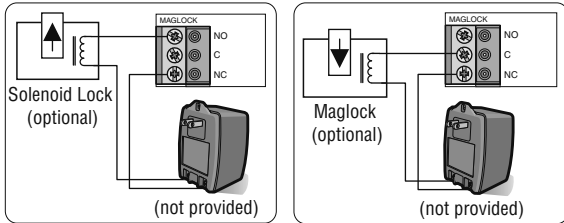

1. ANTENNA INPUT
2. CLOSE EDGE
3. OPEN EDGE/PHOTO EYE
4. OPEN PHOTO EYE
5. CLOSE PHOTO EYE
6. 24VDC ACCESSORY OUTPUT
7. CONTROL INPUTS/EXIT LOOP
8. LOOP INPUTS, SAFETY/SHADOW
9. TRANSFORMER INPUT
10. SECOND - OPERATOR ARM CONNECTION
11. 24VDC ACCESSORY OUTPUT
12. MASTER OPERATOR ARM CONNECTION

13. MAGLOCK/SOLENOID OUTPUT
14. FAULT ALARM OUTPUT
15. BATTERY INPUT #1
16. BATTERY INPUT #2
17. DIP SWITCH, S1
18. LEARN XMITTER
19. MASTER GATE JOG
20. LIMIT SET
21. SECOND GATE JOG
22. SBC (SINGLE BUTTON CONTROL)
23. FORCE SET
24. BIPART DELAY SET
25. TIMER TO CLOSE SET

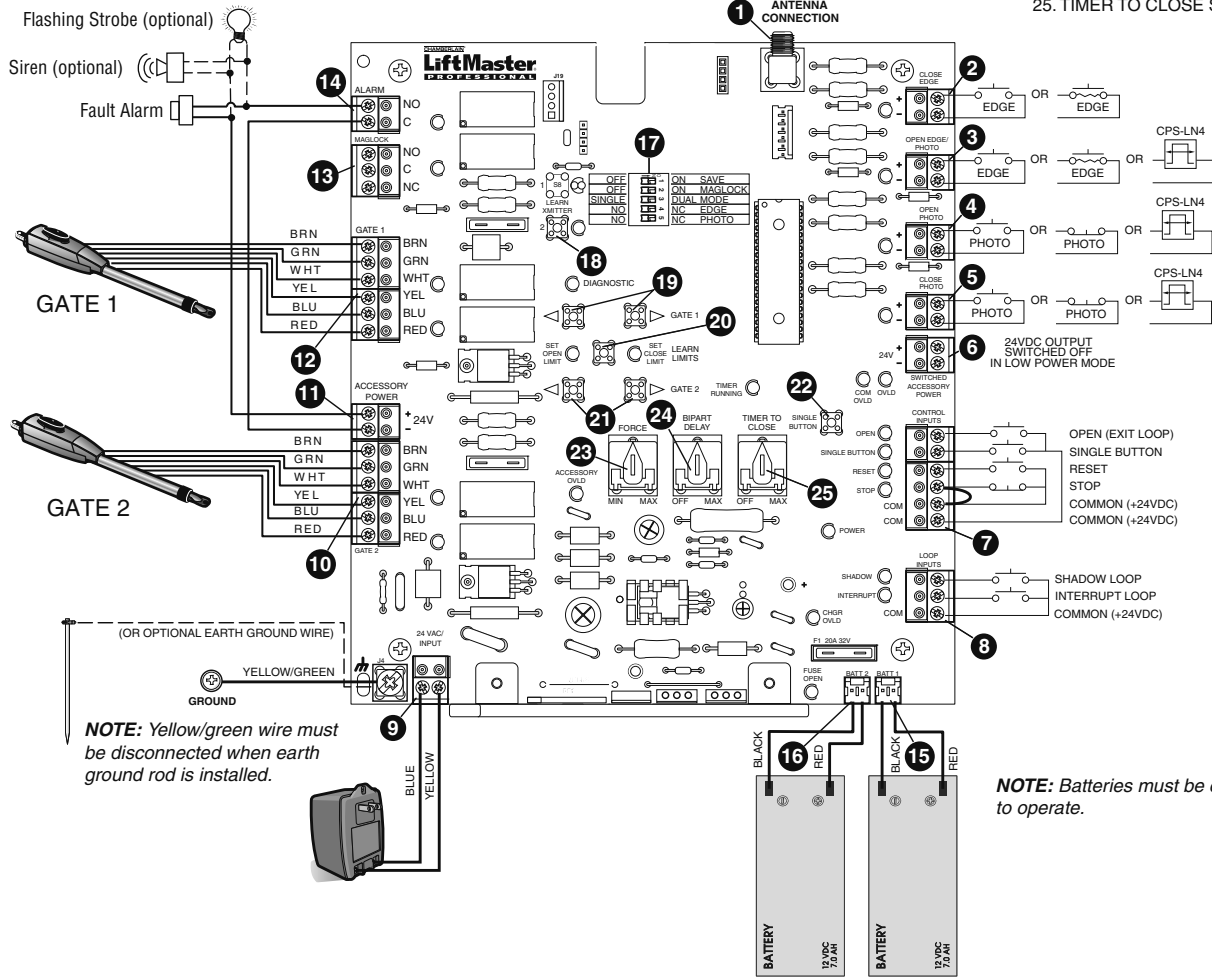

### DIAGNOSTIC CODES

# OF BLINKS	MEANING	# OF BLINKS	MEANING
1	No Stop Switch Connected	6	Force Reversal
2	Gate 1 Arm Disengaged	7	Processor Reset
3	Gate 2 Arm Disengaged	8	ROM Check Failed
4	Both Gate Arms Disengaged	9	RAM Check Failed
5	RPM Reversal	10	EEPROM Check Failed - Reset Limits

# TROUBLESHOOTING » TROUBLESHOOTING CHART

FAULT	POSSIBLE CAUSE	FIX
OPERATOR IS DEAD No LED lights are on.	<ol style="list-style-type: none"> <li>1) No voltage to board.</li> <li>2) Bad control board.</li> </ol>	<p>Battery must be &gt;23 V, AC or needs to be connected.</p> <p>Replace control board.</p>
OPERATOR DOES NOT RUN Operator does not respond to any commands.	<ol style="list-style-type: none"> <li>1) Low/disconnected battery.</li> <li>2) Remote not programmed.</li> <li>3) STOP connection loose/disconnected.</li> <li>4) Constant Open Command (Check LED's).</li> <li>5) Limits not programmed correctly.</li> <li>6) Bad control board.</li> </ol>	<p>Voltage must be &gt;23 V at battery connection.</p> <p>See Programming Remote instructions.</p> <p>Check STOP connections.</p> <p>Clear all Open/Safety devices from obstruction.</p> <p>See Programming Limits instructions.</p> <p>Replace control board.</p>
MOTOR DOES NOT RUN Relays "click" when radio or SBC signal is given, but the operator does not move.	<ol style="list-style-type: none"> <li>1) Low Battery.</li> <li>2) Cable wiring between control box and operator arm disconnected or loose.</li> <li>3) Batteries not connected.</li> <li>4) Bad motor.</li> <li>5) Bad control board.</li> </ol>	<p>Voltage must be &gt;23 V at battery connection.</p> <p>Check wiring on control board to arm, replace wire if needed.</p> <p>Connect batteries.</p> <p>Replace motor.</p> <p>Replace control board.</p>
GATE STOPS AND REVERSES (Force Reversal)	<ol style="list-style-type: none"> <li>1) Gate met an obstruction.</li> <li>2) Force set too low.</li> <li>3) Bad gate hardware.</li> <li>4) Incorrect Arm installation.</li> </ol>	<p>Clear gate from obstruction.</p> <p>See Force Adjustment section.</p> <p>Service/replace gate hardware.</p> <p>See Installation section of operator arm.</p>
RPM REVERSAL	<ol style="list-style-type: none"> <li>1) Obstructed Arm (bottoms out).</li> <li>2) Bad RPM Sensor.</li> <li>3) Too much mA pulled off board.</li> </ol>	<p>Check for obstruction on arm, verify arm is not bottomed out.</p> <p>Replace arm.</p> <p>Move accessories to separate power source. Use reference chart on next page to determine max mA draw for circuit board.</p>
GATE STOPS Gate starts to run, then stops and does not reverse.	<ol style="list-style-type: none"> <li>1) Low battery.</li> <li>2) Gate met an obstruction.</li> </ol>	<p>Voltage must be &gt;23 V at battery connection.</p> <p>Clear gate from obstruction.</p>
GATE OPENS BUT DOES NOT CLOSE	<ol style="list-style-type: none"> <li>1) Constant Open Command (Check LED's).</li> <li>2) Timer-to-Close not set.</li> <li>3) Accessory device wired to Open Only command.</li> </ol>	<p>Clear all Open/Safety devices from obstruction.</p> <p>See Timer-to-Close section for adjustment instructions.</p> <p>Rewire desired accessory device to Single Button Input.</p>
Audible beeps (3 times) when command is given.	<ol style="list-style-type: none"> <li>1) Battery Low &gt;23.5 V</li> </ol>	<p>Operator will resume normal operation once battery voltage reaches 24 V.</p>
GATE'S DO NOT OPEN/CLOSE IN SYNC	<ol style="list-style-type: none"> <li>1) Bipart Delay not set.</li> <li>2) Limits not programmed correctly.</li> <li>3) Incorrect Arm Installation</li> </ol>	<p>See Bipart Delay section for adjustment instructions.</p> <p>See Programming Limits section for instructions.</p> <p>See Installation section for instructions.</p>
GATE DOES NOT AUTOMATICALLY CLOSE Auto Close Timer not closing gate.	<ol style="list-style-type: none"> <li>1) Timer-to-Close not turned on.</li> <li>2) Gate has opened on Obstruction Reversal.</li> <li>3) Operator in "Party Mode".</li> <li>4) Constant Open Command (Check LED's).</li> </ol>	<p>See Timer-to-Close section for instructions.</p> <p>Check DIAG code, clear obstruction.</p> <p>Use remote control/SBC to resume normal operation.</p> <p>Clear all Open/Safety devices from obstruction.</p>
ACCESSORY DEVICE NOT WORKING PROPERLY	<ol style="list-style-type: none"> <li>1) Not installed properly.</li> <li>2) Enabling Switch not turned on.</li> <li>3) Loose/disconnected wires.</li> <li>4) Bad accessory device</li> </ol>	<p>Check for proper installation of accessory.</p> <p>Turn applicable switches on.</p> <p>Check proper installation of wires.</p> <p>Replace accessory device.</p>

# REPAIR PARTS » CONTROL BOX + GATE OPERATOR ARM

## CONTROL BOX

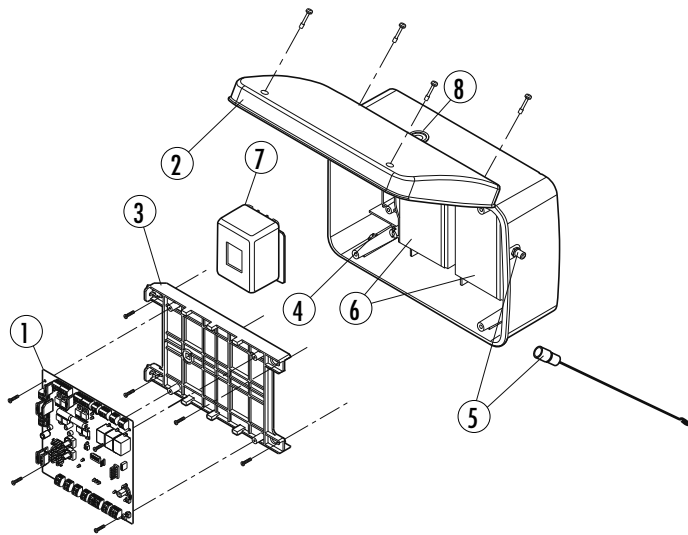

Refer to the parts lists below for replacement parts available for your operator. If optional modifications and/or accessories are included with your operator, certain components may be added or removed from these lists.

ITEM	PART #	DESCRIPTION	QTY
1	K001A6039	Control Board	1
2	K75-15480	Control Box & Cover with Gasket	1
3	K75-30764	Control Board Bracket	1
4	K23-19380	Reset Switch	1
5	K74-19499	Antenna	1
6	K74-30762	Battery	2
7	K74-30763	Transformer	1
8	K76-19446	Alarm	1
<b>Not Shown</b>			
	K74-30941	ATC Fuse Kit Includes 20 Amp (1), 15 Amp (2)	
	K001A5747-2	Receiver Module - 390 MHz	
	K001A5747	Receiver Module - 315 MHz	
	K76-35600	Reset Switch (XLM Control Box)	
	K76-35364	Alarm (XLM Control Box)	

## GATE OPERATOR ARM

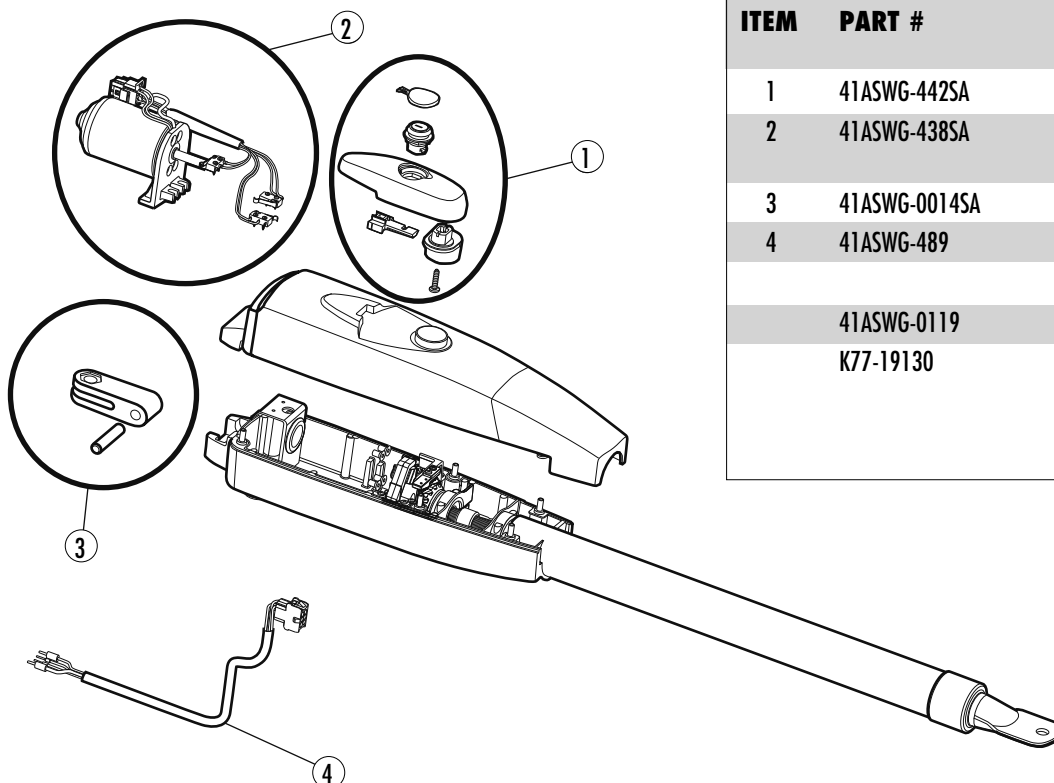

ITEM	PART #	DESCRIPTION	QTY
1	41ASWG-442SA	Release Lever	1
2	41ASWG-438SA	Motor with Limit Switch Harness	1
3	41ASWG-0014SA	Rear Connector	1
4	41ASWG-489	Cable 24 V with Connector	1
<b>Not Shown</b>			
	41ASWG-0119	Release Key	1
	K77-19130	Hardware Bag Complete with: Gate bracket, post bracket, Pull-to-Open bracket and hardware	

# REPAIR PARTS » HOW TO ORDER REPAIR PARTS

## HOW TO ORDER REPAIR PARTS

OUR LARGE SERVICE ORGANIZATION  
SPANS AMERICA

FOR INSTALLATION AND SERVICE INFORMATION,  
CALL OUR TOLL FREE NUMBER

**1-800-528-2806**

[www.liftmaster.com](http://www.liftmaster.com)

**WHEN ORDERING REPAIR PARTS  
PLEASE SUPPLY THE FOLLOWING INFORMATION:**

**PART NUMBER DESCRIPTION MODEL NUMBER**

ADDRESS ORDER TO:

THE CHAMBERLAIN GROUP, INC.  
Technical Support Group  
6050 S. Country Club Road  
Tucson, AZ 85706

## WARRANTY POLICY

### LIFTMASTER TWO YEAR LIMITED WARRANTY

The Chamberlain Group, Inc. warrants to the first purchaser of this product, for the structure in which this product is originally installed, that it is free from defect in materials and/or workmanship for a period of two years from the date of purchase. The proper operation of this product is dependent on your compliance with the instructions regarding installation, operation, maintenance and testing. Failure to comply strictly with those instructions will void this limited warranty in its entirety.

If, during the limited warranty period, this product appears to contain a defect covered by this limited warranty, call 1-800-528-2806, toll free, before dismantling this product. Then send this product, pre-paid and insured, to our service center for warranty repair. You will be advised of shipping instructions when you call. Please include a brief description of the problem and a dated proof-of-purchase receipt with any product returned for warranty repair. Products returned to Seller for warranty repair, which upon receipt by Seller are confirmed to be defective and covered by this limited warranty, will be repaired or replaced (at Seller's sole option) at no cost to you and returned pre-paid. Defective parts will be repaired or replaced with new or factory-rebuilt parts at Seller's sole option.

**ALL IMPLIED WARRANTIES FOR THE PRODUCT, INCLUDING BUT NOT LIMITED TO ANY IMPLIED WARRANTIES OF MERCHANTABILITY AND FITNESS FOR A PARTICULAR PURPOSE, ARE LIMITED IN DURATION TO THE TWO YEAR LIMITED WARRANTY PERIOD SET FORTH ABOVE, AND NO IMPLIED WARRANTIES WILL EXIST OR APPLY AFTER SUCH PERIOD. Some States do not allow limitations on how long an implied warranty lasts, so the above limitation may not apply to you. THIS LIMITED WARRANTY DOES NOT COVER NON-DEFECT DAMAGE, DAMAGE CAUSED BY IMPROPER INSTALLATION, OPERATION OR CARE (INCLUDING, BUT NOT LIMITED TO ABUSE, MISUSE, FAILURE TO PROVIDE REASONABLE AND NECESSARY MAINTENANCE, UNAUTHORIZED REPAIRS OR ANY ALTERATIONS TO THIS PRODUCT), LABOR CHARGES FOR REINSTALLING A REPAIRED OR REPLACED UNIT, OR REPLACEMENT OF BATTERIES.**

**THIS LIMITED WARRANTY DOES NOT COVER ANY PROBLEMS WITH, OR RELATING TO, THE GARAGE DOOR OR GARAGE DOOR HARDWARE, INCLUDING BUT NOT LIMITED TO THE DOOR SPRINGS, DOOR ROLLERS, DOOR ALIGNMENT OR HINGES. THIS LIMITED WARRANTY ALSO DOES NOT COVER ANY PROBLEMS CAUSED BY INTERFERENCE. ANY SERVICE CALL THAT DETERMINES THE PROBLEM HAS BEEN CAUSED BY ANY OF THESE ITEMS COULD RESULT IN A FEE TO YOU.**

**UNDER NO CIRCUMSTANCES SHALL SELLER BE LIABLE FOR CONSEQUENTIAL, INCIDENTAL OR SPECIAL DAMAGES ARISING IN CONNECTION WITH USE, OR INABILITY TO USE, THIS PRODUCT. IN NO EVENT SHALL SELLER'S LIABILITY FOR BREACH OF WARRANTY, BREACH OF CONTRACT, NEGLIGENCE OR STRICT LIABILITY EXCEED THE COST OF THE PRODUCT COVERED HEREBY. NO PERSON IS AUTHORIZED TO ASSUME FOR US ANY OTHER LIABILITY IN CONNECTION WITH THE SALE OF THIS PRODUCT.**

Some states do not allow the exclusion or limitation of consequential, incidental or special damages, so the above limitation or exclusion may not apply to you. This limited warranty gives you specific legal rights, and you may also have other rights which vary from state to state.

# ACCESSORIES

50-19503

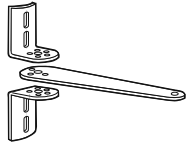

**Push-to-Open Bracket**

Used to allow the gate operator to push the gate open.

LM202

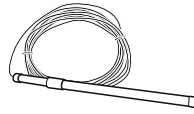

**Vehicle Exit Sensor:**

One piece outdoor buried vehicle motion detector with sensing probe is housed in a small relay type housing so it is easy to integrate with gate, providing for free exit only.

02101

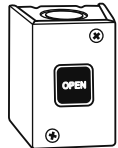

**1-Button Station:**

Steel enclosure wired station will allow for a Open, Close, Stop command of the gate.

GC824-12

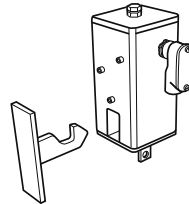

**Gate Solenoid Lock:**

Heavy all steel construction. Fail safe operation keeps gate locked if power is lost. Can be welded onto gate or post. 12 Vdc operation, solenoid-activated release. Can be released in case of an emergency. Requires separate power supply (Model ARMP5).

370LM



**3-Button Mini-Remote Control with SECURITY+®:**

With key ring and fastening strip.

MG1300



**Magnetic Gate Lock:**

Outdoor magnetic lock, transformer, junction box, mounting plate and hardware.

373LM

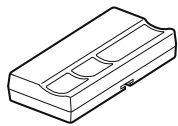

**3-Button SECURITY+® Remote Control:**

Includes visor clip.

29-NP712

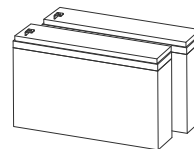

**7 AH/12 Vdc Gate Access System Battery:**

The gate access system battery is a replacement battery for the operator. The model LA400 requires two batteries.

86LM



**Remote Antenna Mounting Kit:**

Kit contains antenna bracket and 15 feet (4.6 m) of cable. Recommended for increasing the effective range of remote controls.

CPS-LN4

**Commercial Protector System® (Direct Connect):**

Maximum range is 45 feet (13.7 m) 24 V. Includes mounting hardware.

377LM

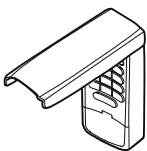

**SECURITY+® Keyless Entry:**

Enables homeowner to operate gate by entering a password on a specially designed keypad.

To order visit [www.liftmaster.com](http://www.liftmaster.com)

# TEMPLATE FOR POST BRACKET MOUNTING

