

# LiftMaster®

ELITE SERIES®

## CSL24V™ & CSL24VH™

### VEHICULAR SLIDE GATE OPERATOR

#### INSTALLATION MANUAL



*Your model may look different than the model illustrated in this manual.*

**THIS PRODUCT IS TO BE  
INSTALLED AND SERVICED BY  
A TRAINED GATE SYSTEMS  
TECHNICIAN ONLY.**

Visit [www.liftmaster.com](http://www.liftmaster.com) to  
locate a professional installing  
dealer in your area.

This model is for use on vehicular  
passage gates **ONLY** and not  
intended for use on pedestrian  
passage gates.

This model is intended for use in  
Class I, II, III and IV vehicular slide  
gate applications.

**UL325**  
compliant



**UL991**  
compliant



# TABLE OF CONTENTS

<b>SAFETY</b>	<b>1-7</b>	<b>FINISH INSTALLATION</b>	<b>24</b>
Safety Symbol and Signal Word Review	1	Install the Cover	24
UL325 Model Classifications	2	<b>OPERATION</b>	<b>25</b>
Safety Installation Information	3	Reset Switch	25
Gate Construction Information	4	Remote Control	25
Required Entrapment Protection Devices	5	Heater (If Applicable)	25
Important Safety Information	6-7	<b>ADDITIONAL FEATURES</b>	<b>26-33</b>
<b>INTRODUCTION</b>	<b>8-9</b>	Control Board Overview	26
Operator Specifications	8	Accessory Features on Control Board	27
Carton Inventory & Operator Dimensions	8	Expansion Board Overview	28
Features	9	Accessory Features on Expansion Board	29
<b>PREPARATION</b>	<b>10-11</b>	Limit Setup with a Remote Control	30-31
Site Preparation	10-11	Gate Operator Setup Examples	32
<b>INSTALLATION</b>	<b>12-13</b>	LiftMaster Internet Gateway	33
Determine Location for Concrete Pad and Operator	12	<b>MAINTENANCE</b>	<b>33</b>
Concrete Pad and Operator Attachment	12	Maintenance Chart	33
Standard Installation Only	13	Batteries	33
Rear Installation Only	13	Drive Chain	33
<b>WIRING</b>	<b>14-20</b>	<b>TROUBLESHOOTING</b>	<b>34-39</b>
Wire the Entrapment Protection Devices	14	Control Board LEDs	34-35
Earth Ground Rod	14	Troubleshooting Chart	36-39
Power Wiring	15-16	<b>REPAIR PARTS</b>	<b>40-41</b>
Connect Batteries	17-18	<b>ACCESSORIES</b>	<b>42-43</b>
Dual Gates Only	19-20	<b>WIRING DIAGRAM</b>	<b>44</b>
<b>ADJUSTMENT</b>	<b>21-22</b>	<b>WARRANTY</b>	<b>45</b>
Limit and Force Adjustment	21-22		
Obstruction Test	22		
<b>PROGRAMMING</b>	<b>23</b>		
Remote Controls	23		
Erase All Codes	23		

## SAFETY

When you see these Safety Symbols and Signal Words on the following pages, they will alert you to the possibility of serious injury or death if you do not comply with the warnings that accompany them. The hazard may come from something mechanical or from electric shock. Read the warnings carefully.

When you see this Signal Word on the following pages, it will alert you to the possibility of damage to your gate and/or the gate operator if you do not comply with the cautionary statements that accompany it. Read them carefully.

### IMPORTANT NOTE

- *BEFORE attempting to install, operate or maintain the operator, you must read and fully understand this manual and follow all safety instructions.*
- *DO NOT attempt repair or service of your gate operator unless you are an Authorized Service Technician.*

### SAFETY SYMBOL AND SIGNAL WORD REVIEW

 **WARNING**

MECHANICAL

 **WARNING**

ELECTRICAL

**CAUTION**

### UL325 MODEL CLASSIFICATIONS

#### CLASS I – RESIDENTIAL VEHICULAR GATE OPERATOR

A vehicular gate operator (or system) intended for use in a home of one-to four single family dwellings, or a garage or parking area associated therewith.

#### CLASS II – COMMERCIAL/GENERAL ACCESS VEHICULAR GATE OPERATOR

A vehicular gate operator (or system) intended for use in a commercial location or building such as a multi-family housing unit (five or more single family units) hotel, garage, retail store or other building servicing the general public.

#### CLASS III – INDUSTRIAL/LIMITED ACCESS VEHICULAR GATE OPERATOR

A vehicular gate operator (or system) intended for use in an industrial location or building such as a factory or loading dock area or other location not intended to service the general public.

#### CLASS IV – RESTRICTED ACCESS VEHICULAR GATE OPERATOR

A vehicular gate operator (or system) intended for use in a guarded industrial location or building such as an airport security area or other restricted access locations not servicing the general public, in which unauthorized access is prevented via supervision by security personnel.

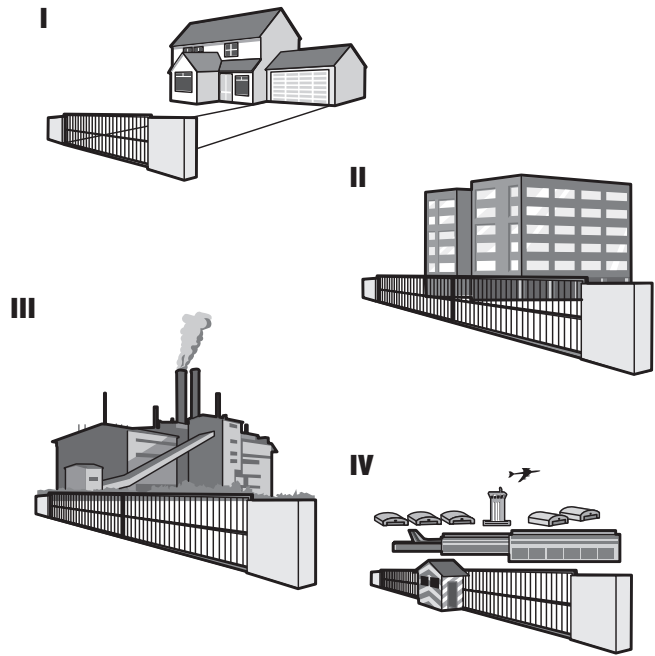

### UL325 ENTRAPMENT PROTECTION REQUIREMENTS

This chart illustrates the entrapment protection requirements for the UL325 classes.

GATE OPERATOR ENTRAPMENT PROTECTION		
UL325 Classification	Slide Gate Operator	
	Primary Type	Secondary Type
CLASS I-CLASS IV	A	B1 or B2

In order to complete a proper installation you must satisfy the entrapment protection chart shown. That means that the installation must have one primary means of entrapment protection and one independent secondary means of entrapment protection. Both primary and secondary entrapment protection methods must be designed, arranged or configured to protect against entrapments in both the open and close directions of gate travel.

For Example: For a gate system that is installed on a single-family residence (UL325 Class I) you must provide the following: As your primary type of entrapment protection you must provide

- Type A - Inherent (built into the operator) entrapment sensing and at least one of the following as your secondary entrapment protection:
  - Type B1 - Non-contact sensors such as photoelectric sensors,
  - Type B2 - Contact sensors such as gate edges

**NOTE:** UL requires that all installations must have warning signs placed in plain view on both sides of the gate to warn pedestrians of the dangers of motorized gate systems.

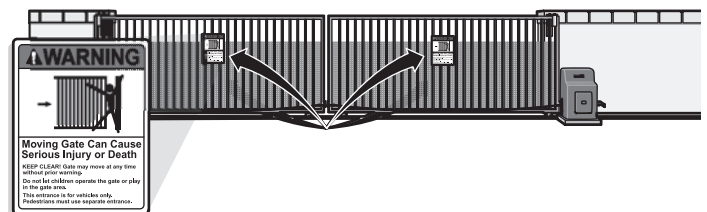

### SAFETY INSTALLATION INFORMATION

1. Vehicular gate systems provide convenience and security. Gate systems are comprised of many component parts. The gate operator is only one component. Each gate system is specifically designed for an individual application.
2. Gate operating system designers, installers and users must take into account the possible hazards associated with each individual application. Improperly designed, installed or maintained systems can create risks for the user as well as the bystander. Gate systems design and installation must reduce public exposure to potential hazards.
3. A gate operator can create high levels of force in its function as a component part of a gate system. Therefore, safety features must be incorporated into every design. Specific safety features include:
  - Gate Edges
  - Photoelectric Sensors
  - Vertical Posts
  - Guards for Exposed Rollers
  - Screen Mesh
  - Instructional and Precautionary Signage
4. Install the gate operator only when:
  - a. The operator is appropriate for the construction and the usage class of the gate.
  - b. All openings of a horizontal slide gate are guarded or screened from the bottom of the gate to a minimum of 4 feet (1.2 m) above the ground to prevent a 2-1/4 inches (6 cm) diameter sphere from passing through the openings anywhere in the gate, and in that portion of the adjacent fence that the gate covers in the open position.

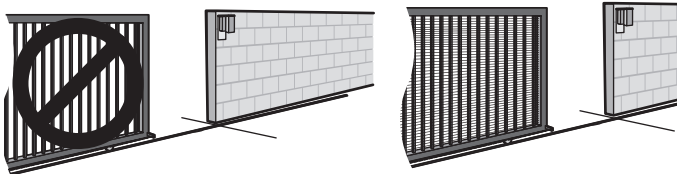

- c. All exposed pinch points are eliminated or guarded, and guarding is supplied for exposed rollers.
5. The operator is intended for installation only on gates used for vehicles. Pedestrians must be supplied with a separate access opening. The pedestrian access opening shall be designed to promote pedestrian usage. Locate the gate such that persons will not come in contact with the vehicular gate during the entire path of travel of the vehicular gate.



6. The gate must be installed in a location so that enough clearance is supplied between the gate and adjacent structures when opening and closing to reduce the risk of entrapment. Swinging gates shall not open into public access areas.
7. The gate must be properly installed and work freely in both directions prior to the installation of the gate operator.

8. Controls intended for user activation must be located at least 6 feet (1.8 m) away from any moving part of the gate and where the user is prevented from reaching over, under, around or through the gate to operate the controls. Outdoor or easily accessible controls shall have a security feature to prevent unauthorized use.



9. The Stop and/or Reset (if provided separately) must be located in the line-of-sight of the gate. Activation of the reset control shall not cause the operator to start.
10. A minimum of two (2) WARNING SIGNS shall be installed, one on each side of the gate where easily visible.

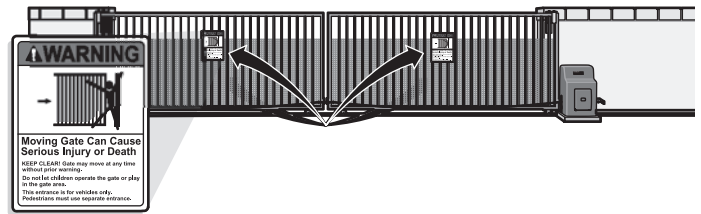

11. For a gate operator utilizing a non-contact sensor:
  - a. Reference owner's manual regarding placement of non-contact sensor for each type of application.
  - b. Care shall be exercised to reduce the risk of nuisance tripping, such as when a vehicle trips the sensor while the gate is still moving.
  - c. One or more non-contact sensors shall be located where the risk of entrapment or obstruction exists, such as the perimeter reachable by a moving gate or barrier.
12. For a gate operator utilizing a contact sensor such as an edge sensor:
  - a. One or more contact sensors shall be located where the risk of entrapment or obstruction exists, such as at the leading edge, trailing edge and post mounted both inside and outside of a vehicular horizontal slide gate.
  - b. One or more contact sensors shall be located at the bottom edge of a vehicular vertical lift gate.
  - c. A hard wired contact sensor shall be located and its wiring arranged so the communication between the sensor and the gate operator is not subject to mechanical damage.
  - d. A wireless contact sensor such as the one that transmits radio frequency (RF) signals to the gate operator for entrapment protection functions shall be located where the transmission of the signals are not obstructed or impeded by building structures, natural landscaping or similar obstruction. A wireless contact sensor shall function under the intended end-use conditions.
  - e. One or more contact sensors shall be located on the inside and outside leading edge of a swing gate. Additionally, if the bottom edge of a swing gate is greater than 6 inches (152 mm) above the ground at any point in its arc of travel, one or more contact sensors shall be located on the bottom edge.
  - f. One or more contact sensors shall be located at the bottom edge of a vertical barrier (arm).

### GATE CONSTRUCTION INFORMATION

Vehicular gates should be installed in accordance with ASTM F2200: Standard Specification for Automated Vehicular Gate Construction. For a copy, contact ASTM directly at 610-832-9585 or [www.astm.org](http://www.astm.org).

#### 1. GENERAL REQUIREMENTS

- 1.1 Gates shall be constructed in accordance with the provisions given for the appropriate gate type listed, refer to ASTM F2200 for additional gate types.
- 1.2 Gates shall be designed, constructed and installed to not fall over more than 45 degrees from the vertical plane, when a gate is detached from the supporting hardware.
- 1.3 Gates shall have smooth bottom edges, with vertical bottom edged protrusions not exceeding 0.50 inches (12.7 mm) when other than the exceptions listed in ASTM F2200.
- 1.4 The minimum height for barbed tape shall not be less than 8 feet (2.44 m) above grade and for barbed wire shall not be less than 6 feet (1.83 m) above grade.
- 1.5 An existing gate latch shall be disabled when a manually operated gate is retrofitted with a powered gate operator.
- 1.6 A gate latch shall not be installed on an automatically operated gate.
- 1.7 Protrusions shall not be permitted on any gate, refer to ASTM F2200 for Exceptions.
- 1.8 Gates shall be designed, constructed and installed such that their movement shall not be initiated by gravity when an automatic operator is disconnected.
- 1.9 A pedestrian gate shall not be incorporated into a vehicular gate panel or that portion of the adjacent fence that the gate covers in the open position.

#### 2. SPECIFIC APPLICATIONS

- 2.1 Any non-automated gate that is to be automated shall be upgraded to conform to the provisions of this specification.
- 2.2 This specification shall not apply to gates generally used for pedestrian access and to vehicular gates not to be automated.
- 2.3 Any existing automated gate, when the operator requires replacement, shall be upgraded to conform to the provisions of this specification in effect at that time.

#### 3. VEHICULAR HORIZONTAL SLIDE GATES

- 3.1 The following provisions shall apply to Class I, Class II and Class III vehicular horizontal slide gates:
  - 3.1.1 All weight bearing exposed rollers 8 feet (2.44 m), or less, above grade shall be guarded or covered.
  - 3.1.2 All openings located between 48 inches (1.22 m) and 72 inches (1.83 m) above grade shall be designed, guarded or screened to prevent a 4 inch (102 mm) diameter sphere from passing through the openings anywhere in the gate, and in that portion of the adjacent fence that covers in the open position.

- 3.1.3 A gap, measured in the horizontal plane parallel to the roadway, between a fixed stationary object nearest the roadway, (such as a gate support post) and the gate frame when the gate is in either the fully open position or the fully closed position, shall not exceed 2 1/4 inches (57 mm), refer to ASTM F2200 for Exception.
- 3.1.4 Positive stops shall be required to limit travel to the designed fully open and fully closed positions. These stops shall be installed at either the top of the gate, or at the bottom of the gate where such stops shall horizontally or vertically project no more than is required to perform their intended function.
- 3.1.5 All gates shall be designed with sufficient lateral stability to assure that the gate will enter a receiver guide, refer to ASTM F2200 for panel types.
- 3.2 The following provisions shall apply to Class IV vehicular horizontal slide gates:
  - 3.2.1 All weight bearing exposed rollers 8 feet (2.44 m), or less, above grade shall be guarded or covered.
  - 3.2.2 Positive stops shall be required to limit travel to the designed fully open and fully closed positions. These stops shall be installed at either the top of the gate, or at the bottom of the gate where such stops shall horizontally or vertically project no more than is required to perform their intended function.

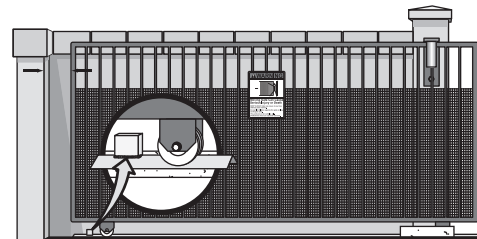

#### 4. VEHICULAR HORIZONTAL SWING GATES

- 4.1 The following provisions shall apply to Class I, Class II and Class III vehicular horizontal swing gates:
  - 4.1.1 Gates shall be designed, constructed and installed so as not to create an entrapment area between the gate and the supporting structure or other fixed object when the gate moves toward the fully open position, subject to the provisions in the 4.1.1.1 and 4.1.1.2.
    - 4.1.1.1 The width of an object (such as a wall, pillar or column) covered by a swing gate when in the open position shall not exceed 4 inches (102 mm), measured from the centerline of the pivot point of the gate, refer to ASTM F2200 for exception.
    - 4.1.1.2 Except for the zone specified in Section 4.1.1.1, the distance between a fixed object such as a wall, pillar or column, and a swing gate when in the open position shall not be less than 16 inches (406 mm), refer to ASTM F2200 for exception.
  - 4.2 Class IV vehicular horizontal swing gates shall be designed, constructed and installed in accordance with security related parameters specific to the application in question.

### REQUIRED ENTRAPMENT PROTECTION DEVICES

#### **⚠ WARNING**

To prevent **SERIOUS INJURY** or **DEATH** from a moving gate:

- Entrapment protection devices **MUST** be installed to protect anyone who may come near a moving gate.
- Locate entrapment protection devices to protect in **BOTH** the open and close gate cycles.
- Locate entrapment protection devices to protect between moving gate and **RIGID** objects, such as posts or walls.

An entrapment zone is every location or point of contact where a person can become entrapped between a moving gate and a stationary object. All gate operator systems **REQUIRE** two independent entrapment protection systems for each entrapment zone. This operator contains an inherent (internal) entrapment protection system (the primary entrapment protection system) and **REQUIRES** the addition of an external entrapment protection system (non-contact photoelectric sensor or contact safety edge sensor) for **EACH** entrapment zone.

Your application may contain one or many entrapment zones. Property owners are obligated to test entrapment protection devices monthly.

#### **CONTACT SENSORS (EDGE SENSORS)**

If the electrically activated edge sensor comes in contact with an obstruction while the gate is moving, the gate will stop and reverse. The gate will not be able to travel in that direction until the obstruction is cleared. Use edge sensor models G65MG0204, G65MGR020, or G65MGS020.

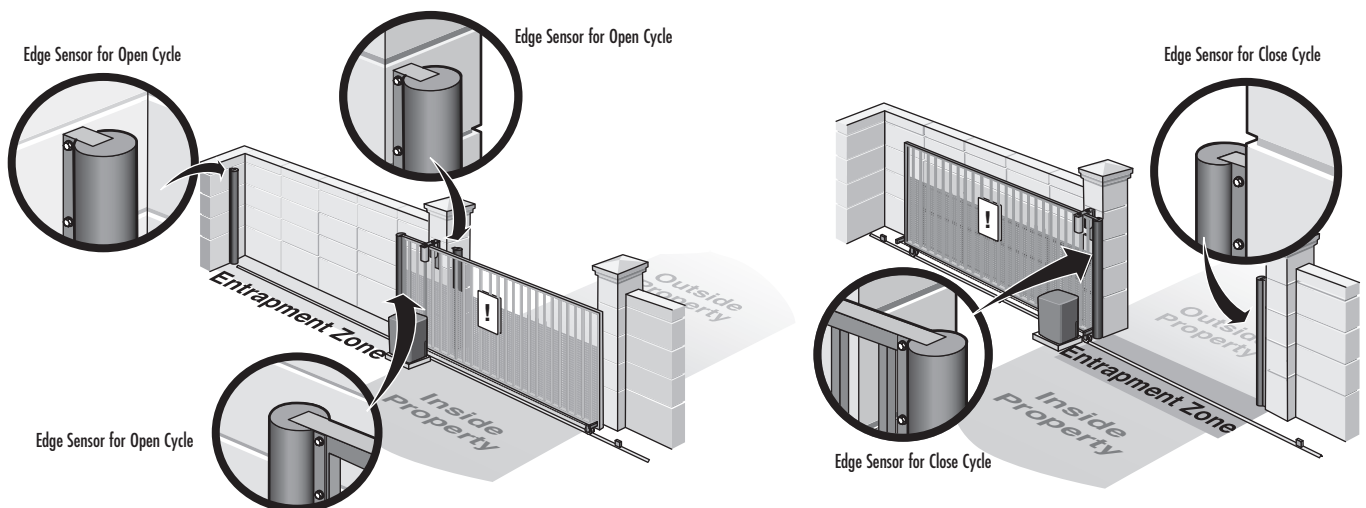

#### **NON-CONTACT SENSORS**

If the photoelectric sensor beam gets blocked while the gate is moving, the gate will stop and reverse. The gate will not be able to travel in that direction until the obstruction is cleared. It is best to use monitored photoelectric sensors, model CPS-UN4. If a monitored photoelectric sensor is not working or loses power or the beam is blocked, then **ALL** gate operation in that direction will stop. Unmonitored photoelectric sensor models AOMRON and RETROAB are also acceptable.

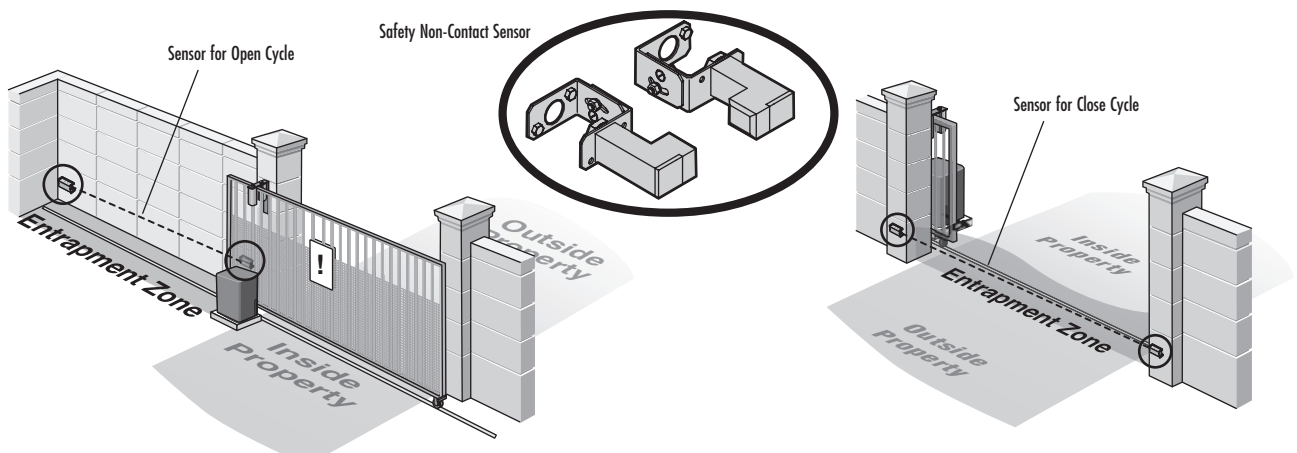



### IMPORTANT SAFETY INFORMATION

#### INSTALLATION

#### WARNING

To prevent **SERIOUS INJURY** or **DEATH** from a moving gate:

- Pinch points must be guarded at all times. Install enclosed-style gate tracks and roller guards.
- Place screen mesh 4 feet (1.2 m) high on the gate to prevent access through openings anywhere the gate may travel.
- Mount controls at least 6 feet (1.8 m) from the gate or ANY moving part of the gate.
- Install Warning signs on EACH side of gate in PLAIN VIEW. Permanently secure each Warning sign in a suitable manner using fastening holes.
- This operator is intended for vehicular use only. To prevent **INJURY** to pedestrians, a separate pedestrian access should be supplied, visible from the gate. Locate the pedestrian access where there is not a chance of **INJURY** at any point during full movement of the gate.
- Contact sensors **MUST** be located at the leading and trailing edges, and post mounted both inside and outside a horizontal slide gate. Non-contact sensors such as photo eyes **MUST** be mounted across the gate opening and operate during BOTH the open and close cycles.
- Entrapment protection devices **MUST** be installed to protect anyone who may come near a moving gate.
- Locate entrapment protection devices to protect in BOTH the open and close gate cycles.
- Locate entrapment protection devices to protect between moving gate and RIGID objects, such as posts or walls.
- Too much force on gate will interfere with proper operation of safety reversal system.
- NEVER increase force beyond minimum amount required to move gate.
- NEVER use force adjustments to compensate for a binding or sticking gate.
- If one control (force or travel limits) is adjusted, the other control may also need adjustment.
- After ANY adjustments are made, the safety reversal system **MUST** be tested. Gate **MUST** reverse on contact with a rigid object.
- DO NOT touch the heater when switch is on, heater may be hot.

#### CAUTION

- To **AVOID** damaging gas, power or other underground utility lines, contact underground utility locating companies **BEFORE** digging more than 18 inches (46 cm) deep.
- ALWAYS wear protective gloves and eye protection when changing the battery or working around the battery compartment.

#### WIRING

#### WARNING

To reduce the risk of **SEVERE INJURY** or **DEATH**:

- ANY maintenance to the operator or in the area near the operator **MUST NOT** be performed until disconnecting the electrical power (AC or solar and battery) and locking-out the power via the operator power switch. Upon completion of maintenance the area **MUST** be cleared and secured, at that time the unit may be returned to service.
- Disconnect power at the fuse box **BEFORE** proceeding. Operator **MUST** be properly grounded and connected in accordance with national and local electrical codes. **NOTE:** *The operator should be on a separate fused line of adequate capacity.*
- ALL electrical connections **MUST** be made by a qualified individual.
- **DO NOT** install ANY wiring or attempt to run the operator without consulting the wiring diagram. We recommend that you install an edge sensor **BEFORE** proceeding with the control station installation.
- ALL power wiring should be on a dedicated circuit and well protected. The location of the power disconnect should be visible and clearly labeled.
- ALL power and control wiring **MUST** be run in separate conduit.

#### ADJUSTMENT

#### WARNING

To reduce the risk of **SEVERE INJURY** or **DEATH**:

- Without a properly installed safety reversal system, persons (particularly small children) could be **SERIOUSLY INJURED** or **KILLED** by a moving gate.
- Too much force on gate will interfere with proper operation of safety reversal system.
- NEVER increase force beyond minimum amount required to move gate.
- NEVER use force adjustments to compensate for a binding or sticking gate.
- If one control (force or travel limits) is adjusted, the other control may also need adjustment.
- After ANY adjustments are made, the safety reversal system **MUST** be tested. Gate **MUST** reverse on contact with a rigid object.



# SAFETY

## IMPORTANT SAFETY INFORMATION

### IMPORTANT SAFETY INFORMATION

#### ADDITIONAL FEATURES

#### WARNING

To prevent **SERIOUS INJURY** or **DEATH** from a moving gate:

- Entrapment protection devices **MUST** be installed to protect anyone who may come near a moving gate.
- Locate entrapment protection devices to protect in **BOTH** the open and close gate cycles.
- Locate entrapment protection devices to protect between moving gate and **RIGID** objects, such as posts or walls.

#### MAINTENANCE AND OPERATION

#### WARNING

To reduce the risk of **SEVERE INJURY** or **DEATH**:

- **READ AND FOLLOW ALL INSTRUCTIONS.**
- **ANY** maintenance to the operator or in the area near the operator **MUST NOT** be performed until disconnecting the electrical power (AC or solar and battery) and locking-out the power via the operator power switch. Upon completion of maintenance the area **MUST** be cleared and secured, at that time the unit may be returned to service.
- Disconnect power at the fuse box **BEFORE** proceeding. Operator **MUST** be properly grounded and connected in accordance with national and local electrical codes. **NOTE:** *The operator should be on a separate fused line of adequate capacity.*
- **NEVER** let children operate or play with gate controls. Keep the remote control away from children.
- **ALWAYS** keep people and objects away from the gate. **NO ONE SHOULD CROSS THE PATH OF THE MOVING GATE.**
- The entrance is for vehicles **ONLY**. Pedestrians **MUST** use separate entrance.
- Test the gate operator monthly. The gate **MUST** reverse on contact with a rigid object or reverse when an object activates the non-contact sensors. After adjusting the force or the limit of travel, retest the gate operator. Failure to adjust and retest the gate operator properly can increase the risk of **INJURY** or **DEATH**.
- Use the manual disconnect release **ONLY** when the gate is not moving.
- **KEEP GATES PROPERLY MAINTAINED.** Read the owner's manual. Have a qualified service person make repairs to gate hardware.
- **ALL** maintenance **MUST** be performed by a LiftMaster professional.
- Activate gate **ONLY** when it can be seen clearly, is properly adjusted and there are no obstructions to gate travel.
- To reduce the risk of **FIRE** or **INJURY** to persons use **ONLY** LiftMaster part 29-NP712 for replacement batteries.
- **SAVE THESE INSTRUCTIONS.**

#### CAUTION

- **ALWAYS** wear protective gloves and eye protection when changing the battery or working around the battery compartment.

#### TROUBLESHOOTING

#### WARNING

To protect against fire and electrocution:

- **DISCONNECT** power (AC or solar and battery) **BEFORE** installing or servicing operator.
- For continued protection against fire:
  - Replace **ONLY** with fuse of same type and rating.

# INTRODUCTION

## OPERATOR SPECIFICATIONS + CARTON INVENTORY & OPERATOR DIMENSIONS

### OPERATOR SPECIFICATIONS

This model is intended for use in vehicular slide gate applications:

**Gate Classifications:** CLASS I, II, III, & IV

**Main AC Supply:** 120 Vac or 240 Vac

**Solar Power Max:** 24 Vdc at 50 watts max.

**Input Rating:**

- CSL24V: 10 Amps at 120 Vac or 2 Amps at 240 Vac
- CSL24VH: 12 Amps at 120 Vac

**Input Rating Excluding Accessory Outlets:**

- CSL24V: 4 Amps at 120 Vac or 2 Amps at 240 Vac
- CSL24VH: 6 Amps at 120 Vac

**\*Input Rating of Accessory Outlets:** 6 Amps at 120 Vac

**\*NOTE:** The accessory outlets are not connected for the 240 Vac rating.

**Main Supply (Motor):** 24 Vdc

**Accessory Power:** 24 V nominal Class II limited to 500 mA

**NOTE:** Increased accessory power drawn from the operator will shorten the battery back-up duration.

**Heater Draw (Optional):** 325 watts (120 Vac ONLY)

**Maximum Gate Weight:** 1500 lbs.

**Maximum Gate Travel Distance:** 50 feet

**Maximum Gate Speed:** 1 foot/second

**Daily Cycle Rate AC power:** Continuous duty

**Ambient Temperature:**

- Without Heater: -20°C to 60°C (-4°F to 140°F)
- With Heater: -40°C to 60°C (-40°F to 140°F)

**Fuse Protection Battery:** 30 Amp

**Fuse Protection DC Power:** 30 Amp

### CARTON INVENTORY & OPERATOR DIMENSIONS

**NOT SHOWN:** Documentation Packet, Chain #41 - 30 feet, Eye Bolt Kit

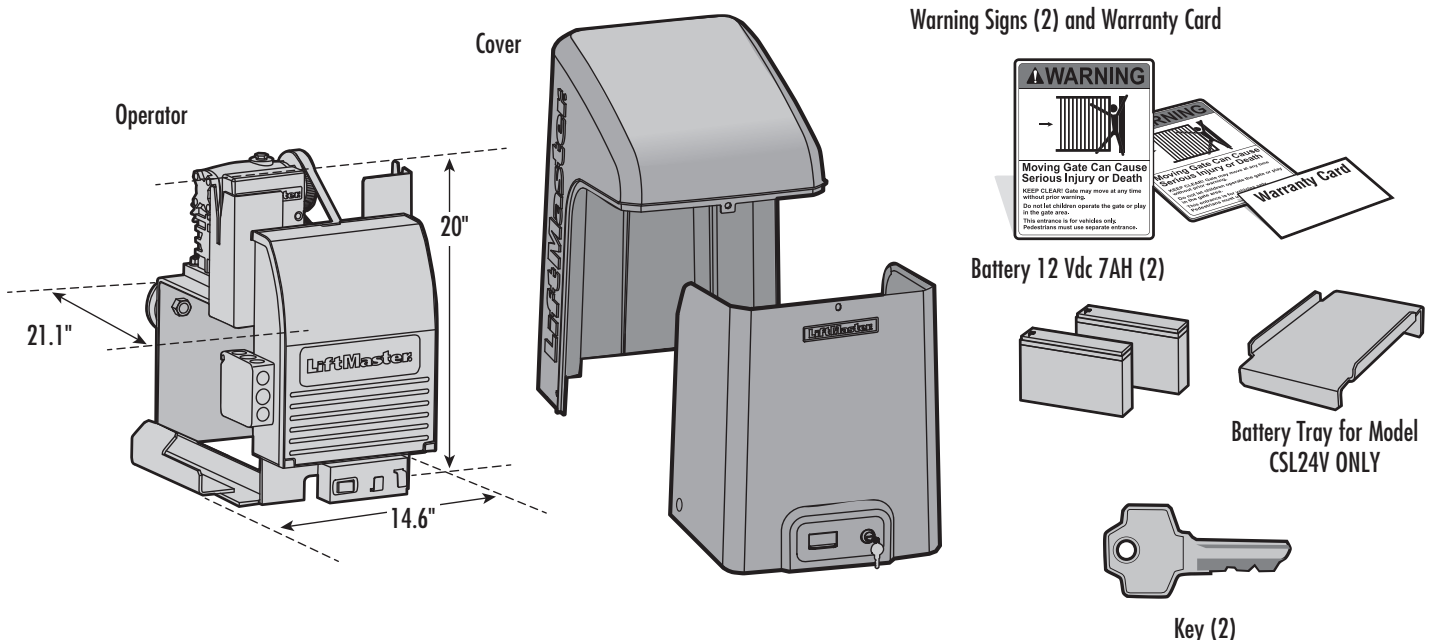

### FEATURES

#### OPERATOR FEATURES

---

- Advanced "Centerpiece" Control Board
- EMI AC Power Surge Protection and Filter Board
  - Main AC voltage input selection: 120 Vac (factory setting) or 240 Vac (field change)
- DC motor with extended brush life
- AC powered with integrated Evercharge battery backup and management
- 24 Vdc accessory power
- Programmable with up to 50 remote controls and 2 keyless entries. Compatible with MyQ™ devices and Security+ 2.0™ codes at either 310, 315, 390 MHz, or 433 MHz
- Manual - Secure power failure selection
- SAMS compatible
- Slow-start and slow-stop gate motion
- Reset Switch
- Audible Alarm
- Internal Heater option (factory installed or field installed) 120 Vac powered ONLY
- Integrated internal antenna with external antenna option
- Electronic limit adjustment and control from the remote control
- Wireless primary/secondary (refer to pages 19-20)

#### CONTROL BOARD FEATURES

---

- Electronic Limit adjustment and control
- Adjustable reversal force
- Adjustable Timer-to-Close (TTC)
- Maximum Run Timer
- Bipart Delay switch (dual gate applications)
- Feedback and Diagnostic LEDs
- Integrated Radio Receiver and 3-Button Station control, six radio frequencies supporting Security+ 2.0™
- COMMANDS:
  - OPEN, CLOSE, or STOP: accessory connection and on-board button
  - FIRE DEPARTMENT OPEN: accessory connection
  - INTEGRATED RADIO RECEIVER
- LOOPS:
  - EXIT, SHADOW, or INTERRUPT LOOP: accessory connection

#### EXPANSION BOARD FEATURES

---

- Plug-in Loop Detector Connectors (Model LOOPDETLM Loop Detector)
  - SHADOW
  - INTERRUPT
  - EXIT, with Fail Safe/Fail Secure selection
- Quick-Close ON/OFF selection switch
- AC Fail Open/Battery selection switch
- Low Battery Open/Close selection switch
- Anti-Tail ON/OFF selection switch
- Single Button Control (SBC) accessory connection
- 3-Button station accessory connection
- AUX Relays (2) each independently selectable operation:
  - OPEN LIMIT: ON at open limit switch
  - CLOSE LIMIT: OFF at close limit switch
  - GATE MOVING: ON with gate moving
  - PRE-ALERT DELAY: ON 3 seconds before gate motion
  - TAMPER: ON when gate manually pulled from close limit
  - POWER: ON with AC or Solar power available
  - CYCLE QUANTITY: LEDs blink operational cycle count

# PREPARATION

## SITE PREPARATION

Check the national and local building codes **BEFORE** installation.



### GATE

Gate must be constructed and installed according to ASTM F2200 standards (refer to page 4). Gate must fit specifications of operator (refer to specifications).

#### SAFETY CATCH ROLLERS

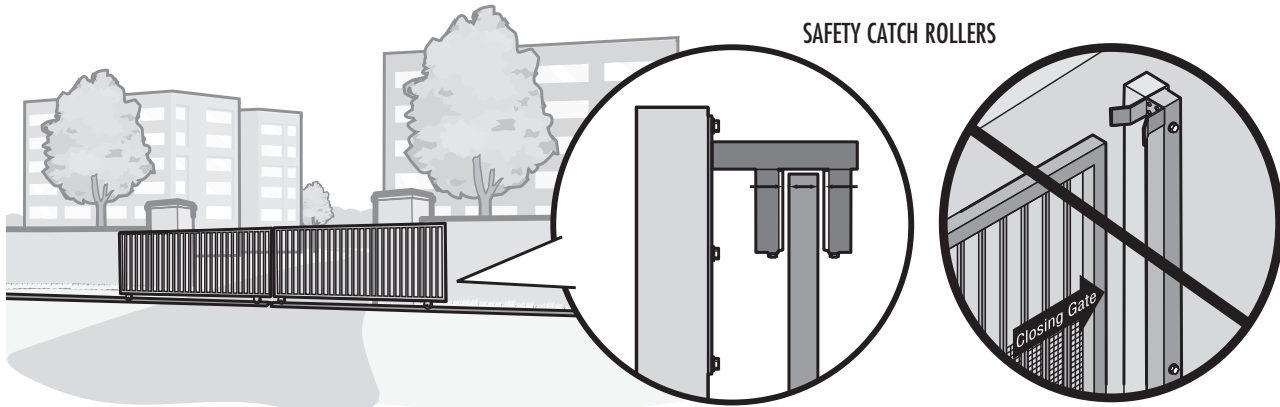

Install catch rollers with safety covers on the side of a post or wall with a minimal distance of half an inch between the rollers and gate.

**DO NOT** use a gate catch post. Because the coasting distance may vary due to changes in temperature, it is **NOT** recommended to install a stop or catch post in front of the gate's path. To do so will cause the gate to hit the post in certain instances.

**CONDUIT & CONCRETE PAD**

Conduit must be UL approved for low and high voltage. Consider the operator placement BEFORE installing the pad or post.

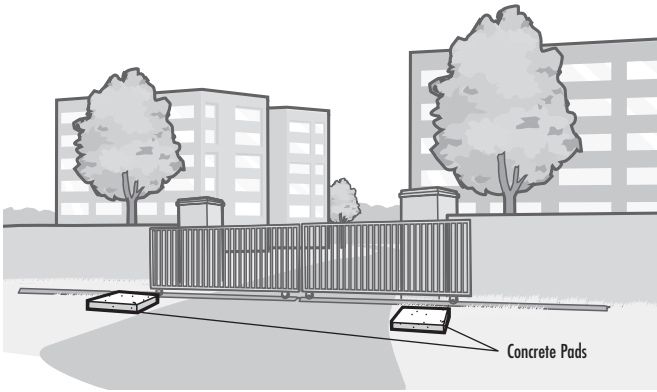

**EARTH GROUND ROD**

Proper grounding gives an electrical charge, such as from an electrical static discharge or a near lightning strike, a path from which to dissipate its energy safely into the earth. Without this path, the intense energy generated by lightning could be directed towards the gate operator. Although nothing can absorb the tremendous power of a direct lightning strike, proper grounding can protect the gate operator in most cases.

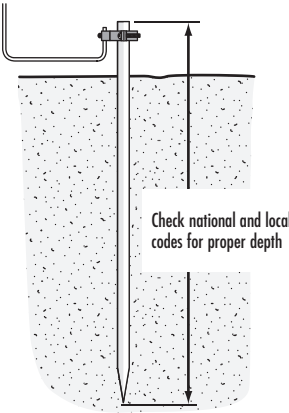

**SAFETY**

Entrapment protection devices are required to protect against any entrapment or safety conditions encountered in your gate application (refer to page 5 for more details). Install warning signs on both sides of the gate.

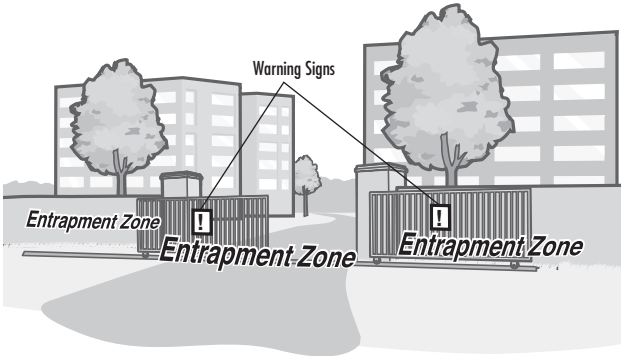

**TYPES OF INSTALLATIONS**

**STANDARD INSTALLATION**

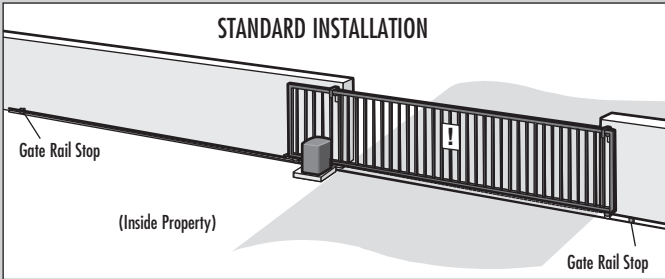

The illustration is an example of a standard installation.

**VEHICLE LOOPS**

The vehicle loops allow the gate to stay open when vehicles are obstructing the gate path. Suggested for vehicles 14 feet (4.27 m) or longer. Vehicle loops are not required but are recommended.

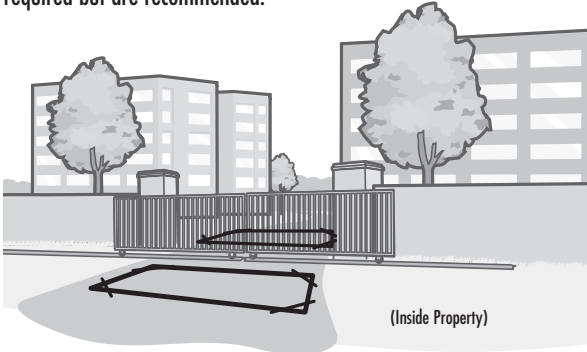

**REAR INSTALLATION**

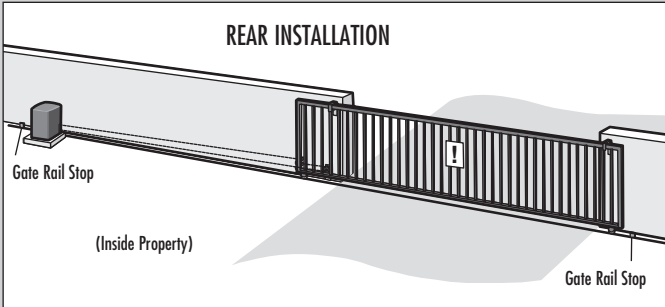

The illustration is an example of a rear installation.

# INSTALLATION

## DETERMINE LOCATION FOR CONCRETE PAD AND OPERATOR + CONCRETE PAD & OPERATOR ATTACHMENT

### DETERMINE LOCATION FOR CONCRETE PAD AND OPERATOR

- 1 The gate operator should be installed near the front roller of the gate or near the back of the gate (in the OPEN position). The space between the gate and the output sprocket must be a minimum of 4 inches.
- 2 Lay out the concrete pad.

#### STANDARD INSTALLATION

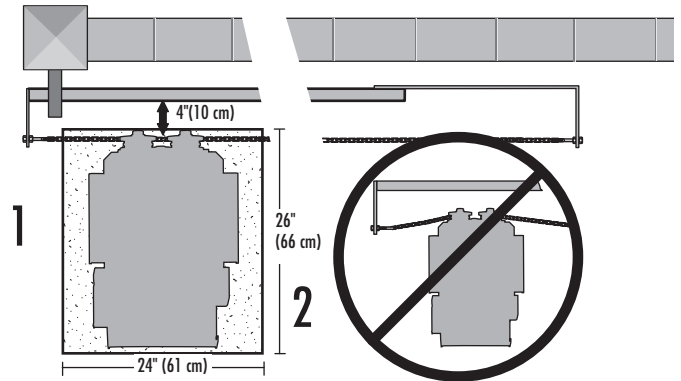

#### REAR INSTALLATION

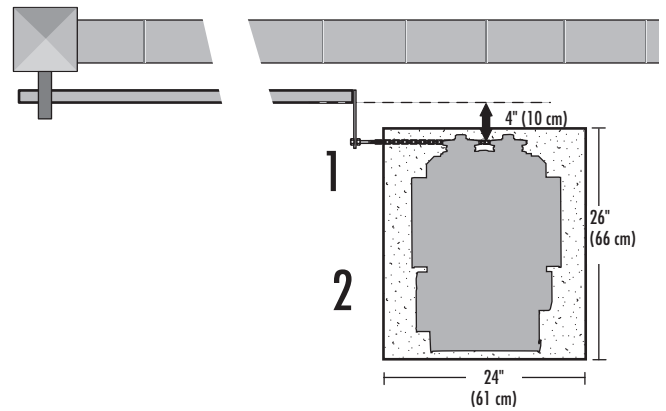

### CONCRETE PAD AND OPERATOR ATTACHMENT

Check the national and local building codes before installation.

- 1 Install the electrical conduit.
- 2 Pour a concrete pad (reinforced concrete is recommended). The concrete pad should be 6 inches above the ground and deeper than the frost line.

- 3 Attach the operator to the concrete pad with appropriate fasteners.  
**NOTE:** An alternative to a concrete pad is to post mount the operator (refer to accessories).

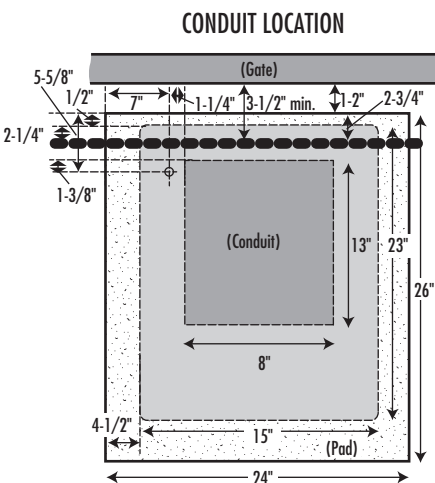

#### MOUNTING FOOTPRINT

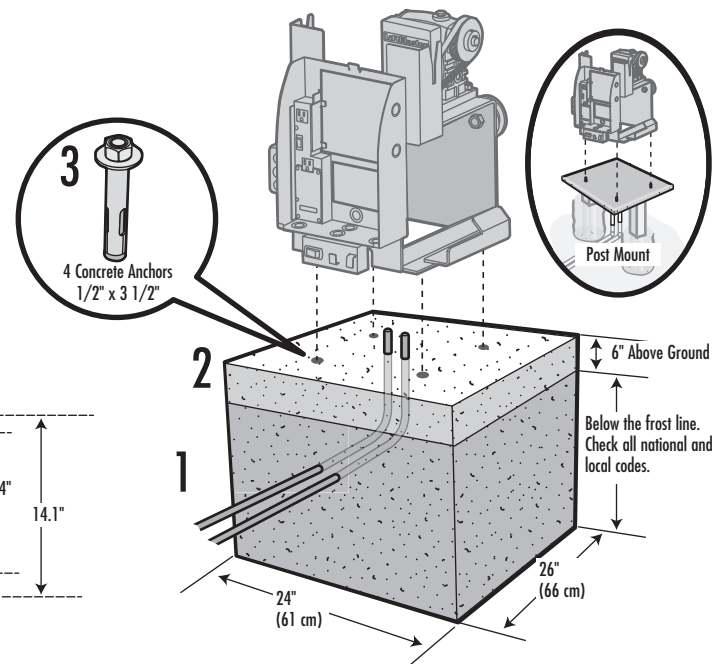
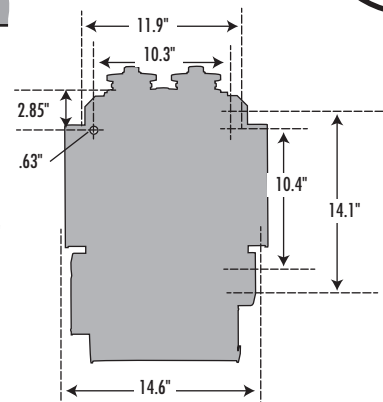

# INSTALLATION

## STANDARD INSTALLATION ONLY + REAR INSTALLATION ONLY

### STANDARD INSTALLATION ONLY

**DO NOT** run the operator until instructed.

- 1 Manually open the gate and line up the front bracket so the chain will be level with the idler pulley and parallel to the ground. Weld the front bracket in this position.
- 2 Manually close the gate and line up the rear bracket so the chain will be level with the idler pulley and parallel to the ground. Weld the rear bracket in this position.
- 3 Route the chain through the operator.
- 4 Connect the chain to the brackets using the eye bolt hardware. Chain should not be too tight or have excessive slack.

**NOTE:** The chain should have no more than 1 inch of sag for every 10 feet of chain length.

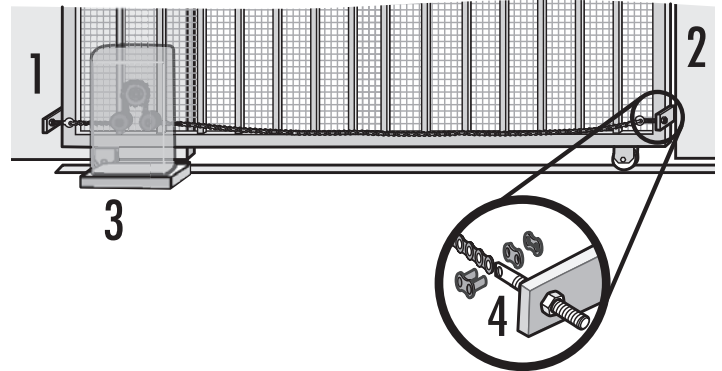

### REAR INSTALLATION ONLY

**DO NOT** run the operator until instructed.

**NOTE:** This installation will require two extra idler pulleys. Make sure all exposed pinch points are guarded. Refer to Gate Construction Information on page 4.

- 1 Move the back pulley to the bottom hole in the operator.
- 2 Manually close the gate and align the bottom bracket so the chain will be level with the bottom idler pulley and parallel to the ground. Weld the bottom bracket in this position.
- 3 Align the top bracket so the chain will be level with the top idler pulley and parallel to the ground. Weld the upper bracket in this position.
- 4 Route the chain through the operator.
- 5 Connect the chain to the brackets using the eye bolt hardware. Chain should not be too tight or have excessive slack. The chain should have no more than 1 inch of sag for every 10 feet of chain length.

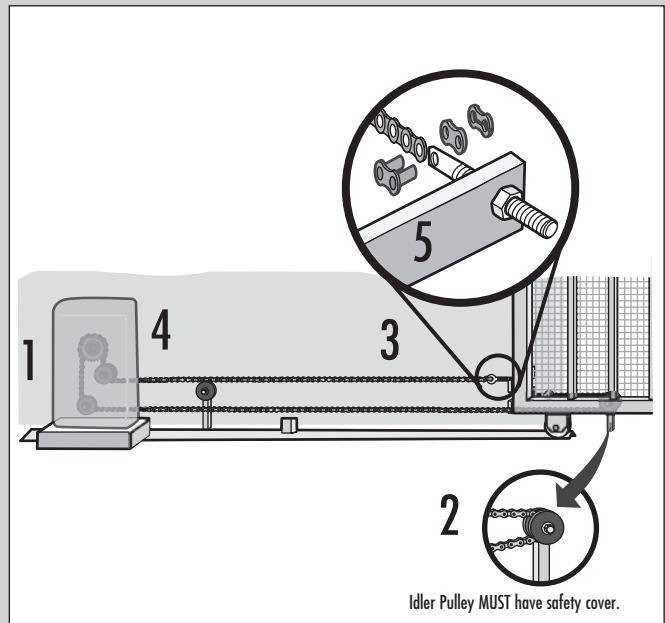

### REMOVE THE PIN FROM THE VENT PLUG

- 1 Remove the pin from the vent plug on the gear box.

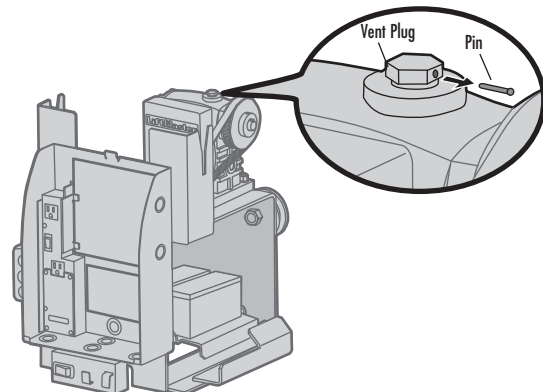



# WIRING

## WIRE THE ENTRAPMENT PROTECTION DEVICES + EARTH GROUND ROD

### WIRE THE ENTRAPMENT PROTECTION DEVICES

Entrapment protection devices are required. Refer to page 5 for more information regarding application.

#### **⚠ WARNING**

To prevent **SERIOUS INJURY** or **DEATH** from a moving gate:

- Entrapment protection devices **MUST** be installed to protect anyone who may come near a moving gate.
- Locate entrapment protection devices to protect in **BOTH** the open and close gate cycles.
- Locate entrapment protection devices to protect between moving gate and **RIGID** objects, such as posts or walls.

**1** Connect the entrapment protection device to the EYES EDGE terminal on the control board. These inputs are for pulsed photoelectric sensors and dry contact edges.

- Close Photoelectric Sensor Entrapment Protection: Connect wires from the photoelectric sensors to the Inputs on the CLOSE EYES/INTERRUPT terminal.
- Close Edge Entrapment Protection: Connect wires from the entrapment protection device to the Inputs on the CLOSE EDGE terminal.
- Open Entrapment Protection: Connect wires from the entrapment protection device to the Inputs on the OPEN EYES/EDGE terminal.

**NOTE:** Refer to the "Accessory Features on the Control Board" section on page 27.

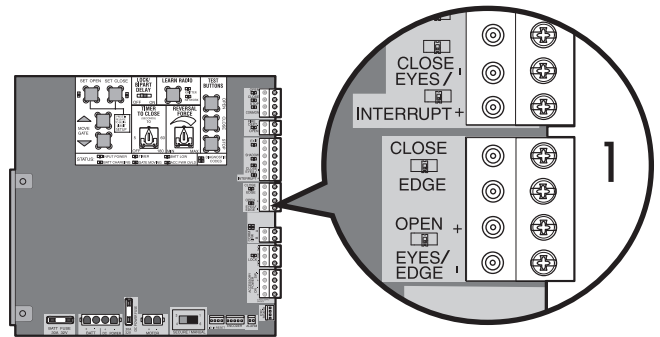

### TO ERASE LEARNED MONITORED PHOTOELECTRIC SENSORS

- 1** Remove the photoelectric sensor wires from the terminal block.
- 2** Press and release the SET OPEN and SET CLOSE buttons simultaneously until the SET OPEN and SET CLOSE LEDs turn on.
- 3** Press and release both SET OPEN and SET CLOSE buttons again to turn off the SET OPEN and SET CLOSE LEDs.

**NOTE:** For dual gate applications repeat the steps above on the other operator.

### EARTH GROUND ROD

Use the proper earth ground rod for your local area. The ground wire must be a single, whole piece of wire. Never splice two wires for the ground wire. If you should cut the ground wire too short, break it, or destroy its integrity, replace it with a single wire length.

- 1** Install the earth ground rod within 3 feet of the operator.
- 2** Run wire from the earth ground rod to the operator.

**NOTE:** If the operator is not grounded properly the range of the remote controls will be reduced.

To Operator

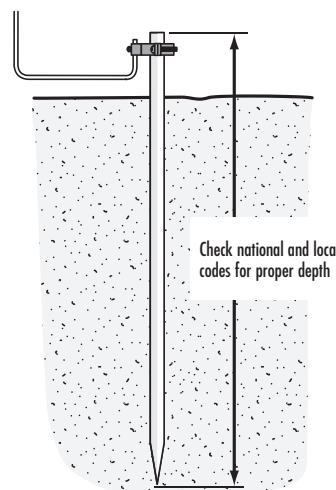

## POWER WIRING

This operator can be wired for either 120 Vac or 240 Vac or a solar panel (not provided). Follow the directions according to your application. For dual gate applications, power will have to be connected to each operator. Main power supply and control wiring **MUST** be run in separate conduits.

**NOTE:** If using an external receiver use shielded wire for the connections and mount the receiver away from the operator to avoid interference with the operator.

AMERICAN WIRE GAUGE (AWG)	MAXIMUM WIRE LENGTH (120 VAC)	MAXIMUM WIRE LENGTH (240 VAC)
14	130 feet	260 feet
12	205 feet	410 feet
10	325 feet	650 feet
8	520 feet	1040 feet
6	825 feet	1650 feet
4	1312 feet	2624 feet

**NOTE:** Use copper conductors **ONLY**.

### AC POWER SWITCH

The AC Power switch on the operator will turn the incoming 120/240 Vac power ON or OFF. The operator's AC Power switch **ONLY** turns off AC power to the control board and **DOES NOT** turn off battery power.

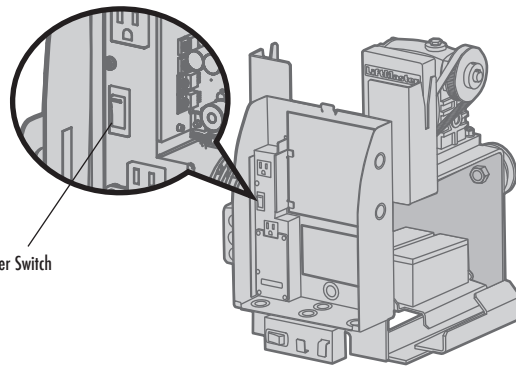

AC Power Switch

### 240 VAC ONLY

If using the 240 Vac option a heater cannot be used. The accessory outlet is disabled and cannot be used with the 240 Vac option.

- 1 Remove the outlet housing from the electrical box by removing the screws (2).
- 2 Pull the outlet housing out and locate the power wiring connector on the EMI board.
- 3 Unplug the power wiring connector from the 120 Vac socket (factory default location) and plug it into the 240 Vac socket.
- 4 Replace the outlet housing by securing with the screws. The operator is now set for 240 Vac operation.

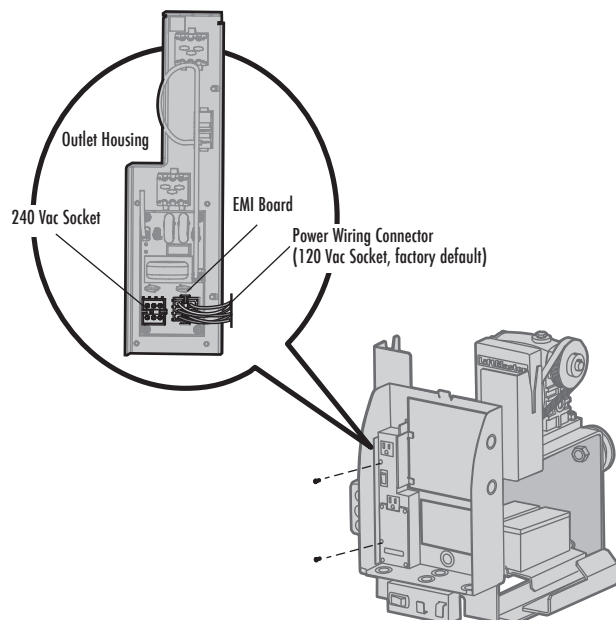

NUMBER OF CYCLES PER DAY					
Slide Gate Installation (16 ft. 1000 lb. gate)					
	Accessory Current Draw			Single Gate	
	50 mA	100 mA	300 mA	7AH Batteries (standard)	33AH Batteries (optional)
<b>TRANSFORMER POWERED</b>				Continuous	Continuous
	✓			Continuous	Continuous
		✓		Continuous	Continuous
			✓	Continuous	Continuous
<b>BATTERY POWERED</b>				100	275
	✓			45	270
		✓		45	270
			✓	40	260

# WIRING

## POWER WIRING CONTINUED...

### 120 VAC AND 240 VAC

- 1 Turn off the AC power from the main power source circuit breaker.
- 2 Run the AC power wires to the junction box on the operator.
- 3 Remove the junction box cover.
- 4 Connect the green wire to the earth ground rod and AC ground using a wire nut. **NOTE:** The earth ground rod can be grounded to the chassis.
- 5 Connect the white wire to NEUTRAL using a wire nut.
- 6 Connect the black wire to HOT using a wire nut.
- 7 Replace the junction box cover. Ensure the wires are not pinched.

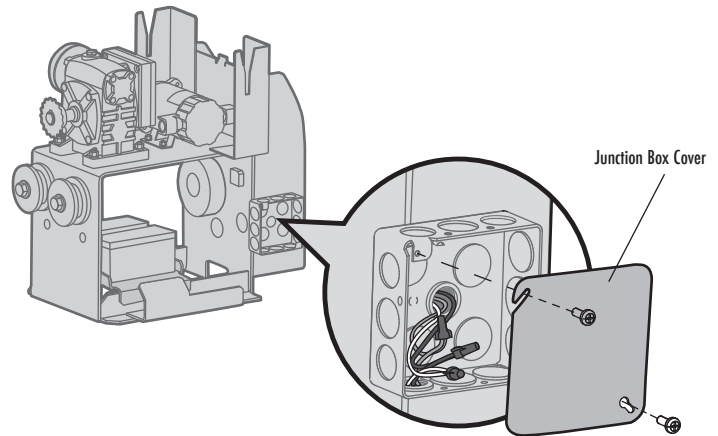

### SOLAR PANEL(S)

NOT PROVIDED. SEE ACCESSORIES.

#### Solar Application requirements:

- A minimum of two 10W solar panels in series
- Two 33AH batteries with new wire harness (Model K94-36596). The standard 7AH batteries cannot be used.
- A heater cannot be used with a solar application

For solar applications **DO NOT** use the expansion board and the wireless dual gate feature. These features will substantially decrease the cycle rate and standby time of the operator. We recommend LiftMaster low power draw accessories to minimize power draw, refer to accessory page.

The solar panel(s) must be located in an open area clear of obstructions and shading for the entire day. The gate operator is not supported in northern climates where temperatures reach below -4°F. This is due to cold weather and a reduced number of hours of sunlight during the winter months. Cycle rate may vary from solar chart for areas that reach below 32°F. Solar panels should be cleaned on a regular basis for best performance to ensure proper operation.

- 1 Locate the J15 plug on the control board and unplug it from the control board (it will not be used).
- 2 Set the new 33AH batteries in the operator.
- 3 Connect a jumper between the positive (+) terminal of one battery to the negative terminal (-) of the other battery.
- 4 Route the battery wires (the longer set of wires) from the J15 plug (new wire harness) through the back of the electrical box. Connect the red wire to the positive (+) terminal of one battery. Connect the black wire to the negative (-) terminal of the other battery.
- 5 Connect the red wire (+) from one solar panel to the black wire (-) of the other solar panel.
- 6 Connect the shorter red wire (+) from the J15 plug (new wire harness) labeled DC Power to the red wire on one solar panel. Connect the shorter black (-) wire from the J15 plug (new wire harness) labeled DC Power to the black wire from the other solar panel.
- 7 Plug the J15 plug (new wire harness) into the J15 input on the control board. **NOTE:** You may see a small spark when plugging the J15 plug into the board. Proceed to the Dual Gate section (if applicable) or proceed to the Adjustment section.

NUMBER OF CYCLES PER DAY (SOLAR)						
Slide Gate Installation (16 ft. 1000 lb. gate) Solar Power Maximum is 24 Vdc at 50 watts maximum	CONFIGURATION			ZONE 1 (6 Hrs sunlight/day)	ZONE 2 (4 Hrs Sunlight/day)	ZONE 3 (2 Hrs Sunlight/day)
	Transmitters	Wireless Dual Gate	1 Loop (LD/LP)	33AH Batteries	33AH Batteries	33AH Batteries
20W SOLAR PANEL <i>NOTE: 20W would be two 10W (12V) panels in series.</i>				66	39	13
	✓			64	38	12
	✓	✓		59	33	7
	✓	✓	✓	54	28	2
40W SOLAR PANEL <i>NOTE: 40W would be two 20W panels in series.</i>				144	92	39
	✓			142	90	38
	✓	✓		137	85	33
	✓	✓	✓	132	80	28

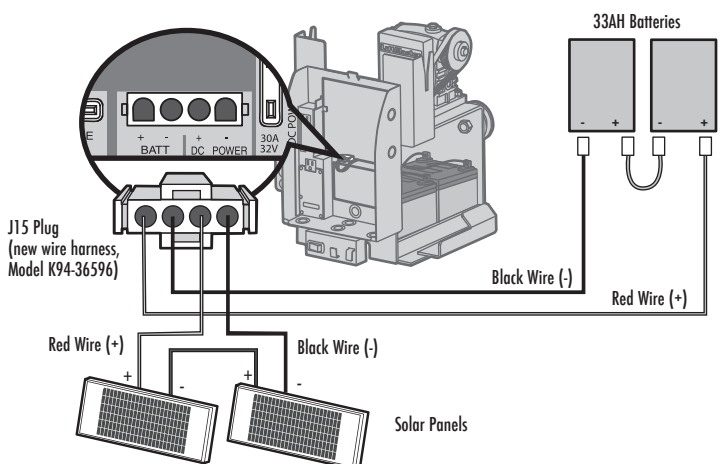
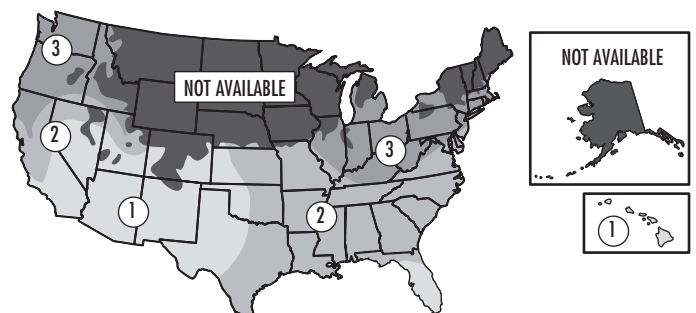

### CONNECT BATTERIES

#### 7AH BATTERIES

The batteries are charged in the circuit by the integrated transformer. The batteries are for battery backup or solar installation.

- 1 Turn OFF AC power to the operator.
- 2 Unplug the J15 plug labeled BATT on the control board by squeezing the plug and pulling it from the control board. This disconnects the ac/dc power to the control board.
- 3 Connect a jumper between the positive (+) terminal of one battery to the negative terminal (-) of the other battery.
- 4 Connect the red wire from the J15 plug to the positive (+) terminal of the battery.
- 5 Connect the black wire from the J15 plug to the negative (-) terminal of the battery.
- 6 Plug the J15 plug back into the control board. This will power up the control board. **NOTE:** You may see a small spark when plugging the J15 plug into the board.
- 7 Turn ON AC power to the operator.
- 8 Turn ON the AC power switch on the operator.

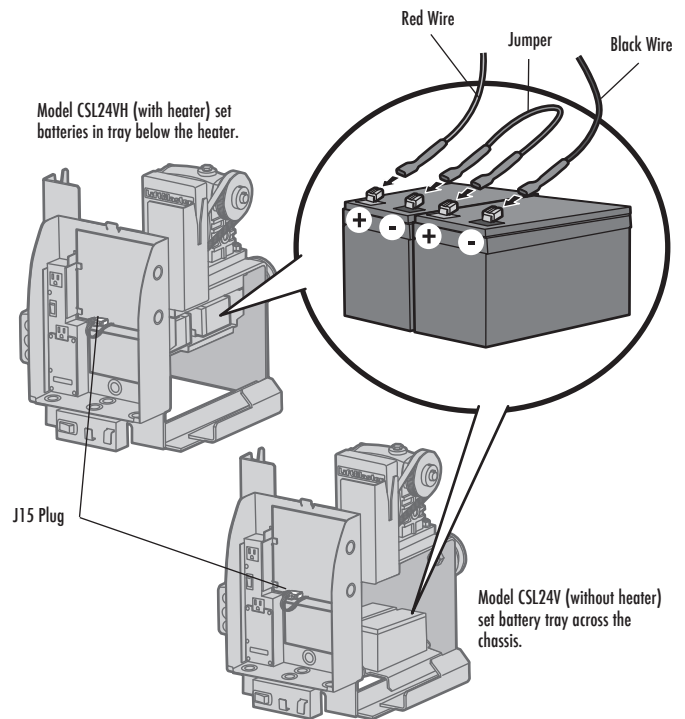

### CONNECT BATTERIES

#### 33AH BATTERIES

The batteries are charged in the circuit by the integrated transformer. The batteries are for battery backup or solar installation. The 33AH application requires the 33AH wire harness (Model K94-36596). **NOTE:** If 33AH batteries (2) are used, the battery tray underneath the heater will need to be removed to allow more space in the enclosure (if applicable).

- 1 Disconnect the red (+) and black (-) wires going from the bridge rectifier to the J15 plug labeled DC POWER on the control board.
- 2 Connect the shorter set of red (+) and black (-) wires from the new 33AH wire harness to the bridge rectifier.
- 3 Connect a jumper between the positive (+) terminal of one battery to the negative (-) terminal of the other battery.
- 4 Connect the longer red wire from the J15 plug (new wire harness) to the positive (+) terminal of the battery.
- 5 Connect the longer black wire from the J15 plug (new wire harness) to the negative (-) terminal of the battery.
- 6 Turn ON AC power to the operator.
- 7 Turn ON the AC power switch on the operator.
- 8 Plug the J15 plug (new battery harness) into the control board. **NOTE:** You may see a small spark when plugging the J15 plug into the board.

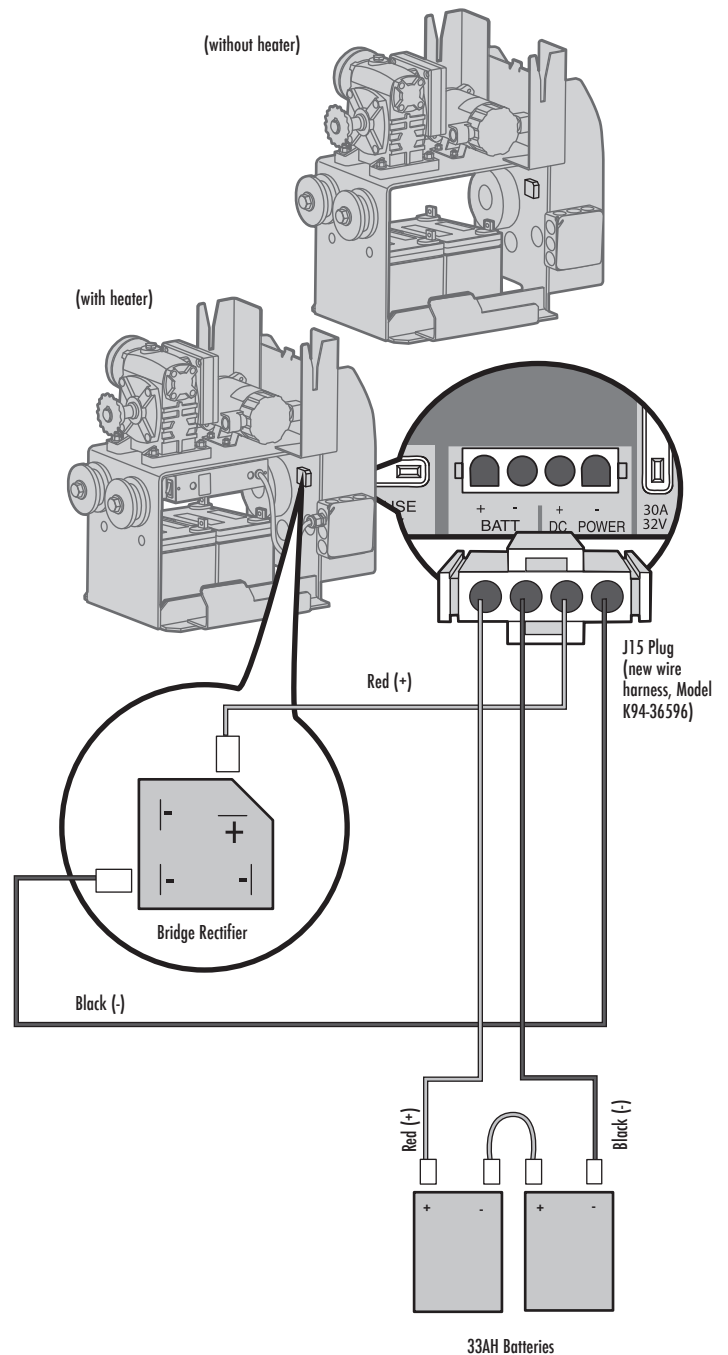

## DUAL GATES ONLY

There are two options for dual gate communication: wired or wireless. Follow the directions according to your application. Do not use wired and wireless communication simultaneously. Wired dual gate applications will have a longer battery standby time than wireless applications.

### WIRELESS DUAL GATES

#### TO ACTIVATE THE WIRELESS FEATURE:

- 1 Choose an operator to be the network primary operator. All wireless accessories will need to be programmed to the primary operator. **NOTE:** We recommend that all accessories and board configurations are set on the primary operator.
- 2 Press and release the LEARN RADIO button on the primary operator. The green XMITTER LED will light.
- 3 Press and release the LEARN RADIO button again on the primary operator. The NETWORK LED will light.
- 4 Press and release the OPEN test button to assign this operator as network primary.
- 5 Press and release the LEARN RADIO button on the second operator. The green XMITTER LED will light.
- 6 Press and release the LEARN RADIO button again on the second operator. The NETWORK LED will light.
- 7 Press and release the CLOSE test button to assign this operator as network second.

Both operators will beep and the NETWORK LEDs will turn off indicating programming is successful.

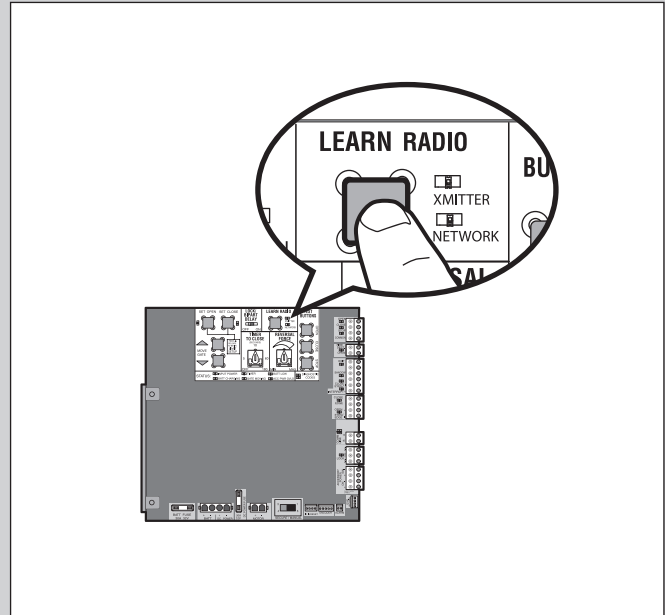

#### TO DEACTIVATE THE WIRELESS FEATURE:

- 1 Press and release the LEARN RADIO button on either operator. The green XMITTER LED will light.
- 2 Press and release the LEARN RADIO button again on the same operator. The yellow NETWORK LED will light.
- 3 Press and hold the LEARN RADIO button for 5 seconds. The yellow NETWORK LED will blink (operator will beep) then turn off indicating successful deactivation.

Repeat the steps for the other operator.

## DUAL GATES ONLY

### WIRED DUAL GATES

Before digging, contact local underground utility locating companies. Use PVC conduit to prevent damage to cables.

Disconnect ALL power to the operator and unplug the J15 plug from the control board.

- 1 Trench across driveway to bury the extension cable.
- 2 Connect the wires from the extension cable to the Comm Link terminals on the primary gate operator control board. **NOTE:** We recommend that all accessories and board configurations are set on the primary operator.
- 3 Route the extension cable to the secondary gate operator's control board.
- 4 Connect the wires from the extension cable to the Comm Link terminals on the secondary control board (Comm Link A to Comm Link A and Comm Link B to Comm Link B).

Connect ALL power to the operator and plug the J15 plug into the control board.

DUAL GATE WIRE TYPE (SHIELDED TWISTED PAIR CABLE)	
22AWG up to 200 feet (61 m)	18AWG - 200-1000 feet (61-305 m)
Wire must be rated at 30 Volt minimum	

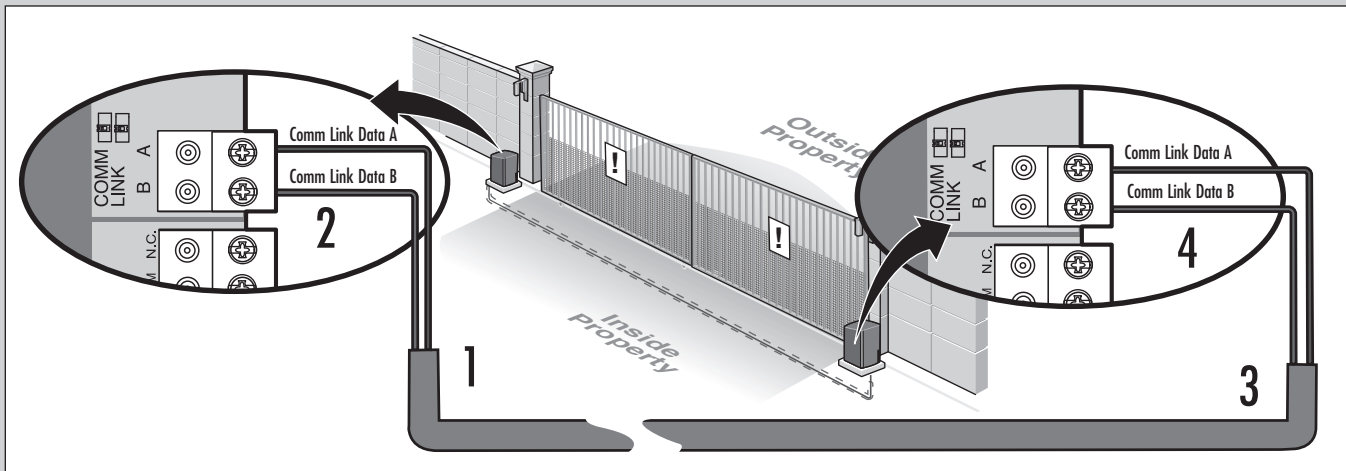

### BIPART DELAY/SYNCHRONIZED CLOSE

The LOCK/BIPART DELAY switch is used only with dual gate applications and serves two functions:

- **BIPART DELAY**

**SWING GATE APPLICATIONS:** The BIPART DELAY is used in applications where a mag-lock, solenoid lock, or decorative overlay would require one gate to close before the other. The operator with the LOCK/BIPART DELAY switch ON will delay from the close limit when opening and be the first to close from the open limit.

**SLIDE GATE APPLICATIONS:** Not applicable, set to OFF.

- **SYNCHRONIZED CLOSE**

The BIPART DELAY is also used in applications where one gate travels a longer distance than the other. To synchronize the closing of the gates, set the LOCK/BIPART DELAY switch to ON for both operators.

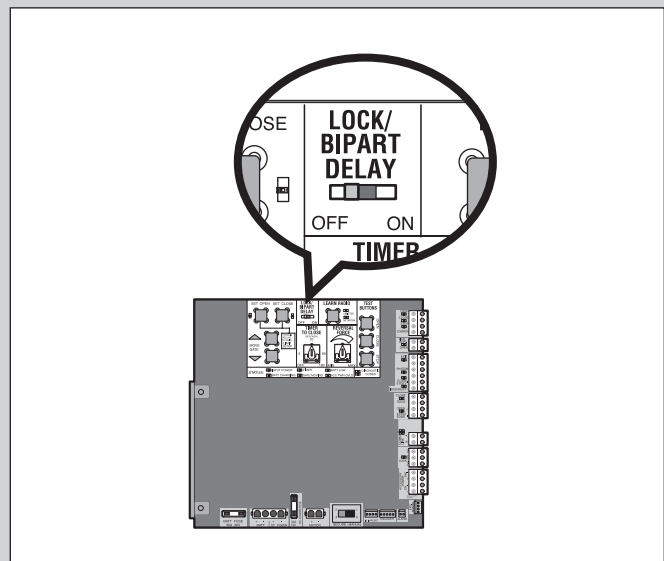



### LIMIT AND FORCE ADJUSTMENT

#### ⚠ WARNING

To reduce the risk of SEVERE INJURY or DEATH:

- Without a properly installed safety reversal system, persons (particularly small children) could be SERIOUSLY INJURED or KILLED by a moving gate.
- Too much force on gate will interfere with proper operation of safety reversal system.
- NEVER increase force beyond minimum amount required to move gate.
- NEVER use force adjustments to compensate for a binding or sticking gate.
- If one control (force or travel limits) is adjusted, the other control may also need adjustment.
- After ANY adjustments are made, the safety reversal system MUST be tested. Gate MUST reverse on contact with a rigid object.

#### INTRODUCTION

Your operator is designed with electronic controls to make travel limit and force adjustments easy. The adjustments allow you to program where the gate will stop in the open and close position. The electronic controls sense the amount of force required to open and close the gate. The force is adjusted automatically when you program the limits but should be fine tuned using the REVERSAL FORCE dial on the control board (refer to Fine Tune the Force section) to compensate for environmental changes.

The limits can be set using the control board (below) or a remote control (refer to Limit Setup with a Remote Control in the Additional Features section). Setting the limits with a remote control requires a 3-button remote control programmed to OPEN, CLOSE, and STOP.

LIMIT SETUP LEDS			
SET OPEN LED	SET CLOSE LED	OPERATOR MODE	EXPLANATION
BLINKING	BLINKING	NORMAL MODE	Limits are not set.
OFF	OFF	NORMAL MODE	Limits are set.
BLINKING	BLINKING	LIMIT SETTING MODE	Limits are not set.
BLINKING	ON	LIMIT SETTING MODE	Open limit is not set.
ON	BLINKING	LIMIT SETTING MODE	Close limit is not set.
ON	ON	LIMIT SETTING MODE	Limits are set.

#### INITIAL LIMITS AND FORCE ADJUSTMENT

For dual gate applications the limits will have to be set for each operator. The gate **MUST** be attached to the operator before setting the limits and force.

- 1 Press and release the SET OPEN and SET CLOSE buttons simultaneously to enter limit setting mode.
- 2 Press and hold one of the MOVE GATE buttons to move the gate to the open or close limit.
- 3 Press and release the SET CLOSE or SET OPEN button depending on which limit is being set.
- 4 Press and hold one of the MOVE GATE button to move the gate to the other limit.
- 5 Press and release the SET CLOSE or SET OPEN button depending on which limit is being set.
- 6 Cycle the gate open and close. This automatically sets the force.

When limits are set properly the operator will automatically exit limit setting mode.

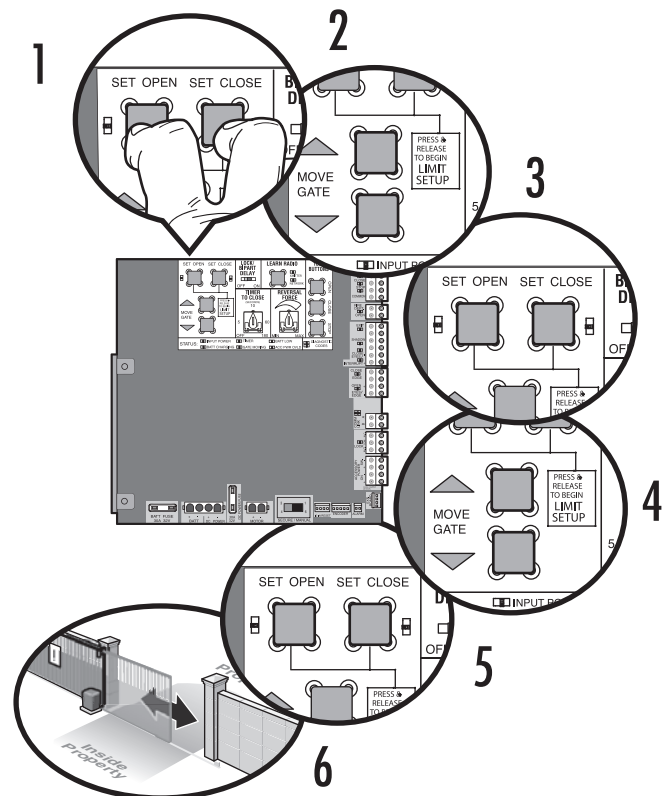

# ADJUSTMENT

## LIMIT AND FORCE ADJUSTMENT + OBSTRUCTION TEST

### FINE TUNE THE FORCE

The FORCE DIAL on the control board is used for fine tuning the force in cases where wind or environmental changes may affect the gate travel.

Based on the length and weight of the gate it may be necessary to make additional force adjustments. The force setting should be high enough that the gate will not reverse by itself nor cause nuisance interruptions, but low enough to prevent serious injury to a person. The force setting is the same for both the open and close gate directions.

- 1 Open and close the gate with the TEST BUTTONS.
- 2 If the gate stops or reverses before reaching the fully open or closed position, increase the force by turning the force control slightly clockwise.
- 3 Perform the "Obstruction Test" after every force setting adjustment (see below).

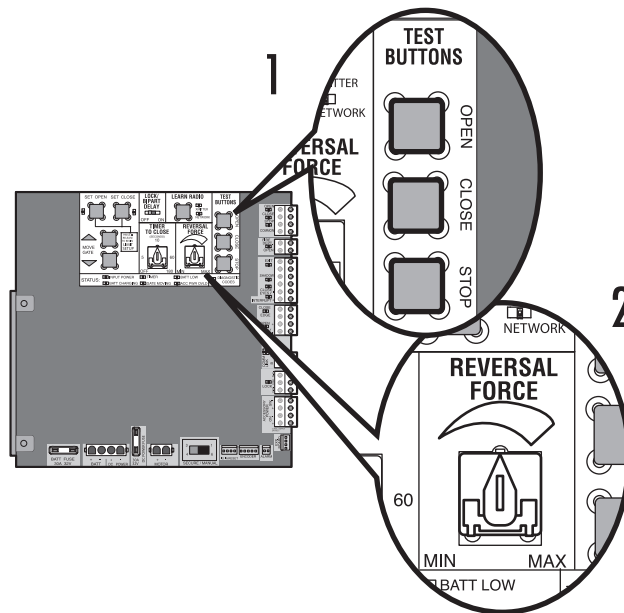

### ADJUST THE LIMITS

If the limits have already been set the operator will exit the limit setting mode after resetting each limit. Each limit is set separately by following steps 1-3 of the Initial Limit and Force Adjustment section.

### ERASE LIMITS

- 1 To erase the limits, press and hold the SET OPEN and SET CLOSE buttons simultaneously (5 seconds) until both the SET OPEN and SET CLOSE LEDs blink rapidly and the operator beeps.
- 2 Release the buttons and the SET OPEN and SET CLOSE LEDs will blink slowly indicating the limits will need to be set.

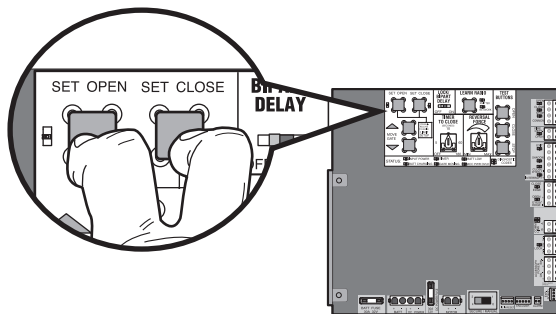

### OBSTRUCTION TEST

The operator is equipped with an automatic obstruction sensing feature. If the gate encounters an obstruction during motion, the operator will automatically reverse direction of the gate for a short time and then stop the gate. After any adjustments are made, test the operator:

- 1 Open and close the gate with the TEST BUTTONS, ensuring that the gate is stopping at the proper open and close limit positions.
- 2 Place a solid object between the open gate and a rigid structure. Ensure that the gate, the solid object, and the rigid structure can withstand the forces generated during this obstruction test.
- 3 Run the gate in the close direction. The gate should stop and reverse upon contact with the solid object. If the gate does not reverse off the solid object, reduce the force setting by turning the force control slightly counter-clockwise. The gate should have enough force to reach both the open and close limits, but MUST reverse after contact with a solid object.
- 4 Repeat the test for the open direction.

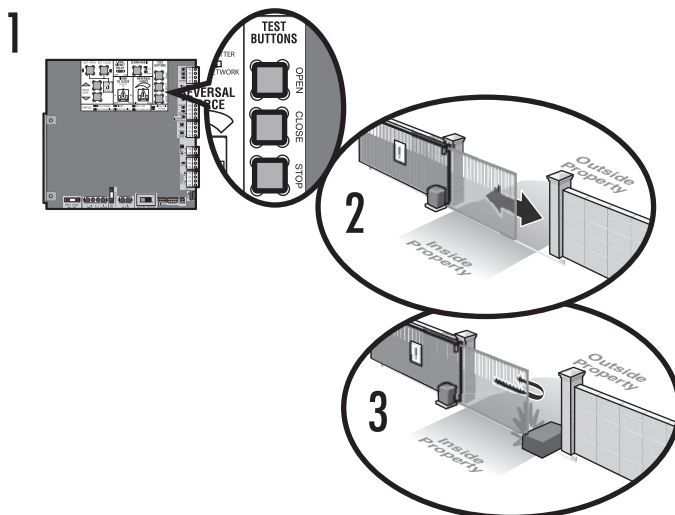

# PROGRAMMING

## REMOTE CONTROLS + ERASE ALL CODES

### REMOTE CONTROLS (NOT PROVIDED)

A total of 50 Security+ 2.0™ remote controls and 2 keyless entries (1 PIN for each keyless entry) can be programmed to the operator. **NOTE:** When the memory is full the operator will exit programming mode and the remote control/keyless entry will not be programmed. The memory will need to be erased before programming any additional remote controls/keyless entries. If installing an 86LM to extend the range of the remote controls DO NOT bend the antenna.

There are 3 different options for programming the remote control depending on how you would like the remote control to function. Choose a programming option:

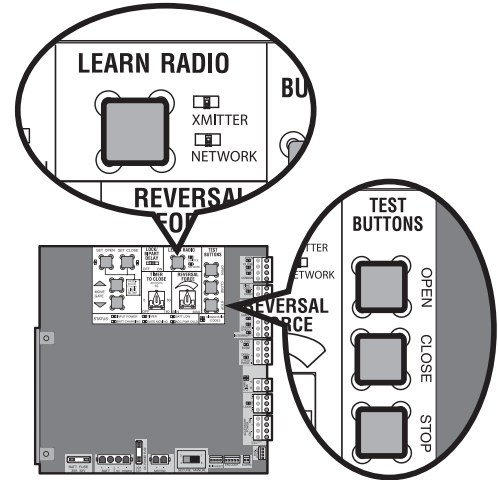

OPTION	DESCRIPTION	PROGRAMMING STEPS
Single button as OPEN only	Program a single button on the remote control for open only. The Timer-to-Close can be set to close the gate.	<ol style="list-style-type: none"> <li>1. Press and release the LEARN button (operator will beep and green XMITTER LED will light).</li> <li>2. Press the OPEN button.</li> <li>3. Press the remote control button that you would like to program.</li> </ol>
Single button as OPEN, CLOSE, and STOP	Program one remote control button as an open, close, and stop.	<ol style="list-style-type: none"> <li>1. Press and release the LEARN button (operator will beep and green XMITTER LED will light).</li> <li>2. Press the remote control button that you would like to program.</li> </ol>
Three separate buttons as OPEN, CLOSE, and STOP	Program each remote control button as an open, close, and stop.	<ol style="list-style-type: none"> <li>1. Press and release the LEARN button (operator will beep and green XMITTER LED will light).</li> <li>2. Press the OPEN, CLOSE, or STOP button, depending on the desired function.</li> <li>3. Press the remote control button that you would like to program.</li> </ol>

The operator will automatically exit learn mode (operator will beep and green XMITTER LED will go out) if programming is successful. To program additional Security+ 2.0™ remote controls or remote control buttons, repeat the programming steps above.

### ERASE ALL CODES

- 1 Press and release the LEARN RADIO button (operator will beep and green XMITTER LED will light).
- 2 Press and hold the LEARN RADIO button again until the green XMITTER LED goes out (approximately 6 seconds). All remote control codes are now erased.

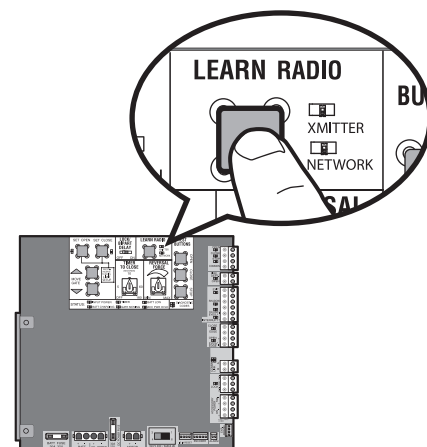

NOTICE: To comply with FCC and/or Industry Canada (IC) rules, adjustment or modifications of this transceiver are prohibited. THERE ARE NO USER SERVICEABLE PARTS. Any changes or modifications not expressly approved by the party responsible for compliance could void the user's authority to operate the equipment.

This device complies with Part 15 of the FCC rules and IC RSS-210. Operation is subject to the following two conditions: (1) this device may not cause harmful interference, and (2) this device must accept any interference received, including interference that may cause undesired operation.

This Class B digital apparatus complies with Canadian ICES-003.

AVIS : Les règles de la FCC et/ou d'Industrie Canada (IC) interdisent tout ajustement ou toute modification de ce récepteur. IL N'EXISTE AUCUNE PIÈCE SUSCEPTIBLE D'ÊTRE ENTRETIENUE PAR L'UTILISATEUR. Tout changement ou toute modification non expressément approuvé par la partie responsable de la conformité peut avoir pour résultat d'annuler l'autorité de l'utilisateur de faire fonctionner l'équipement. Cet appareil est conforme aux dispositions de la partie 15 du règlement de la FCC et de la norme IC RSS-210. Son utilisation est assujettie aux deux conditions suivantes : (1) ce dispositif ne peut causer des interférences nuisibles, et (2) ce dispositif doit accepter toute interférence reçue, y compris une interférence pouvant causer un fonctionnement non souhaité.

Cet appareil numérique de la classe B est conforme à la norme NMB-003 du Canada.

# FINISH INSTALLATION

## INSTALL THE COVER

### INSTALL THE COVER

The operator cover consists of two pieces: a rear cover and a front cover. The front cover can easily be removed to access the electrical box. To access the reset switch slide the access door up. The front cover and access door can be locked with the key.

#### TO INSTALL THE COVER

- 1 Align the tabs on the rear cover with the slots on the chassis and place the cover over the operator.
- 2 Secure both sides of the rear cover to the chassis with two 5/16-18 hex bolts and washers.
- 3 Align the front cover with the back cover, making sure the grooves line up.
- 4 Secure the front cover to the chassis with two 5/16-18 hex bolts and washers.
- 5 Secure the front cover to the rear cover using the 5/16-18 screw.

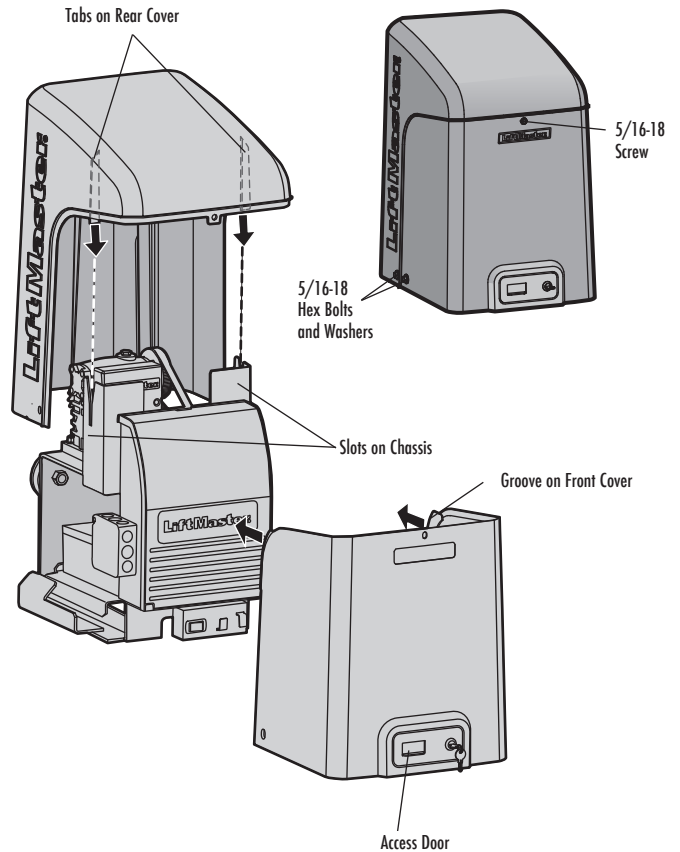

#### TO LOCK THE ACCESS DOOR

From the factory the access door for the reset switch will not be locked. To lock the access door follow the steps below:

- 1 Locate the lock tab on the back of the front cover and remove the screw securing the tab to the cover.
- 2 Turn the tab 180 degrees, then secure with the screw. The access door can now be locked.

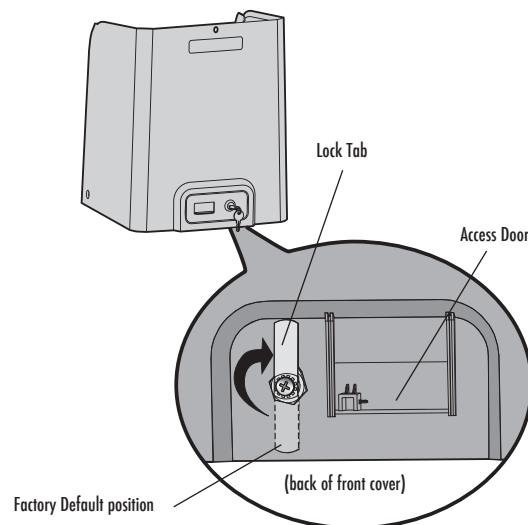

The basic installation is complete.

# OPERATION

## RESET SWITCH + REMOTE CONTROL + HEATER (IF APPLICABLE)

### RESET SWITCH

The reset switch is located on the front of the operator and serves several functions. Toggling the reset switch will stop a moving gate during a normal open/close cycle, like a stop button. The operator does not need to be reset after doing this. The reset switch will disable the gate in the present position and will energize the solenoid lock for two minutes and disable the maglock for two minutes.

#### MANUAL DISCONNECT

Press the reset switch to RESET/DISCONNECT to allow the gate to be opened and closed manually. To resume normal operation press the reset switch to NORMAL OPERATION.

#### OPERATOR ALARM

If a contact sensor detects an obstruction twice consecutively the alarm will sound (up to 5 minutes) and the operator will need to be reset. If a command is given after the initial 5 minutes the operator will beep.

When the inherent force of the operator (RPM/current sensor) detects the following (twice consecutively) the alarm will sound (up to 5 minutes) and the operator will need to be reset:

- A. The gate is hitting a wall or vehicle.
- B. The gate does not meet specifications.
- C. Debris is on the gate's track such as mud, rocks, dirt, etc.
- D. The gate has one or more broken axles or wheels.
- E. The gate wheel is off the gate rail.

Remove any obstructions. Toggle the reset switch to shut off the alarm and reset the operator. After the operator is reset, normal functions will resume.

The operator alarm will beep 3 times with a command if the battery is low.

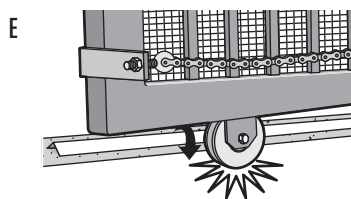
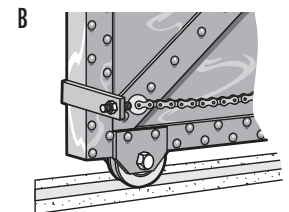
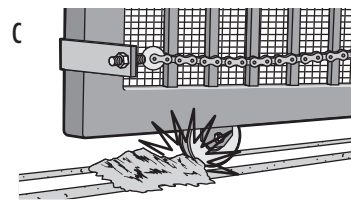
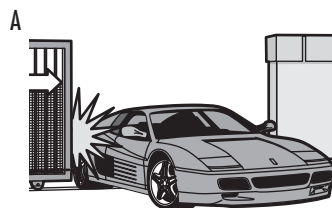
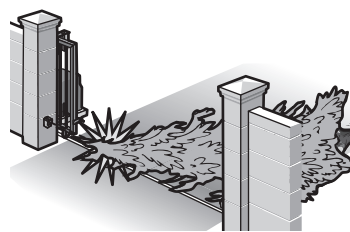
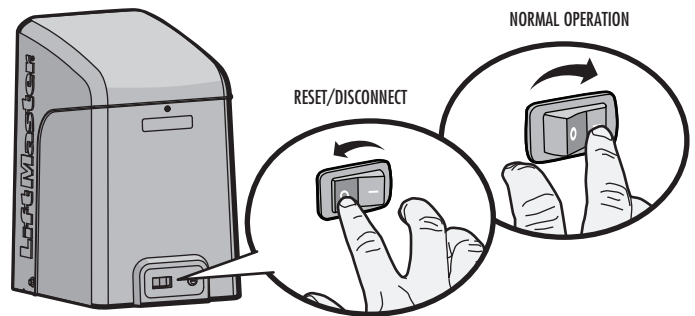

### REMOTE CONTROL

Once the remote control has been programmed the operator will operate as follows:

When gate is in the closed position, activation of the remote control button will open the gate. During the open cycle another activation of the remote control will stop the gate and the next activation of the remote control will close the gate.

When the gate is in the open position, activation of the remote control button will close the gate. If the remote control is activated while the gate is closing, the gate will stop and the next activation will open the gate.

### HEATER (IF APPLICABLE)

The operator may have a heater installed, depending on the model purchased. The heater must be powered by 120 Vac ONLY. If the heater switch is left in the "ON" position, the heater will turn on and off automatically when needed.

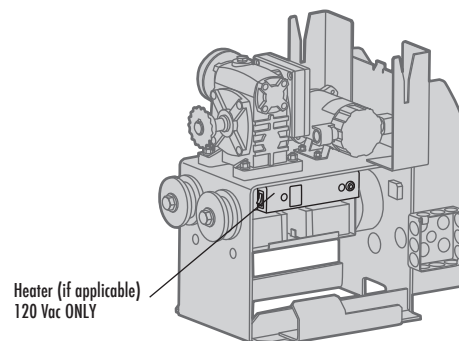

# ADDITIONAL FEATURES

## CONTROL BOARD OVERVIEW

<b>SET OPEN Button</b>	The SET OPEN button sets the OPEN limit. See Adjust Limits section.
<b>SET CLOSE Button</b>	The SET CLOSE button sets the CLOSE limit. See Adjust Limits section.
<b>MOVE GATE Button</b>	The MOVE GATE buttons will either open or close the gate when the operator is in Limit setting mode. See Adjust Limits section.
<b>BIPART DELAY Switch</b>	The LOCK/BIPART DELAY switch is used only for dual gates. See Bipart Delay section.
<b>LEARN RADIO Button</b>	The LEARN RADIO button is for programming remote controls and the network.
<b>TIMER-TO-CLOSE dial</b>	The TIMER-TO-CLOSE (TTC) dial can be set to automatically close the gate after a specified time period. The TTC is factory set to OFF. If the TTC is set to the OFF position, then the gate will remain open until the operator receives another command from a control. Rotate the TIMER-TO-CLOSE dial to the desired setting. The range is 0 to 180 seconds, 0 seconds is OFF. <b>NOTE:</b> Any radio command, single button control, or CLOSE command on the control board prior to the TTC expiring will close the gate. The TTC is reset by any signals from the open controls, loops, close edges, and close photoelectric sensors (IR's).
<b>REVERSAL FORCE dial</b>	The REVERSAL FORCE dial adjusts the force. See Force Adjustment section.
<b>TEST BUTTONS</b>	The TEST BUTTONS will operate the gate (OPEN, STOP and CLOSE).
<b>STATUS LEDs</b>	The STATUS LEDs are diagnostic codes for the operator. See Status LED Chart in the Troubleshooting section.

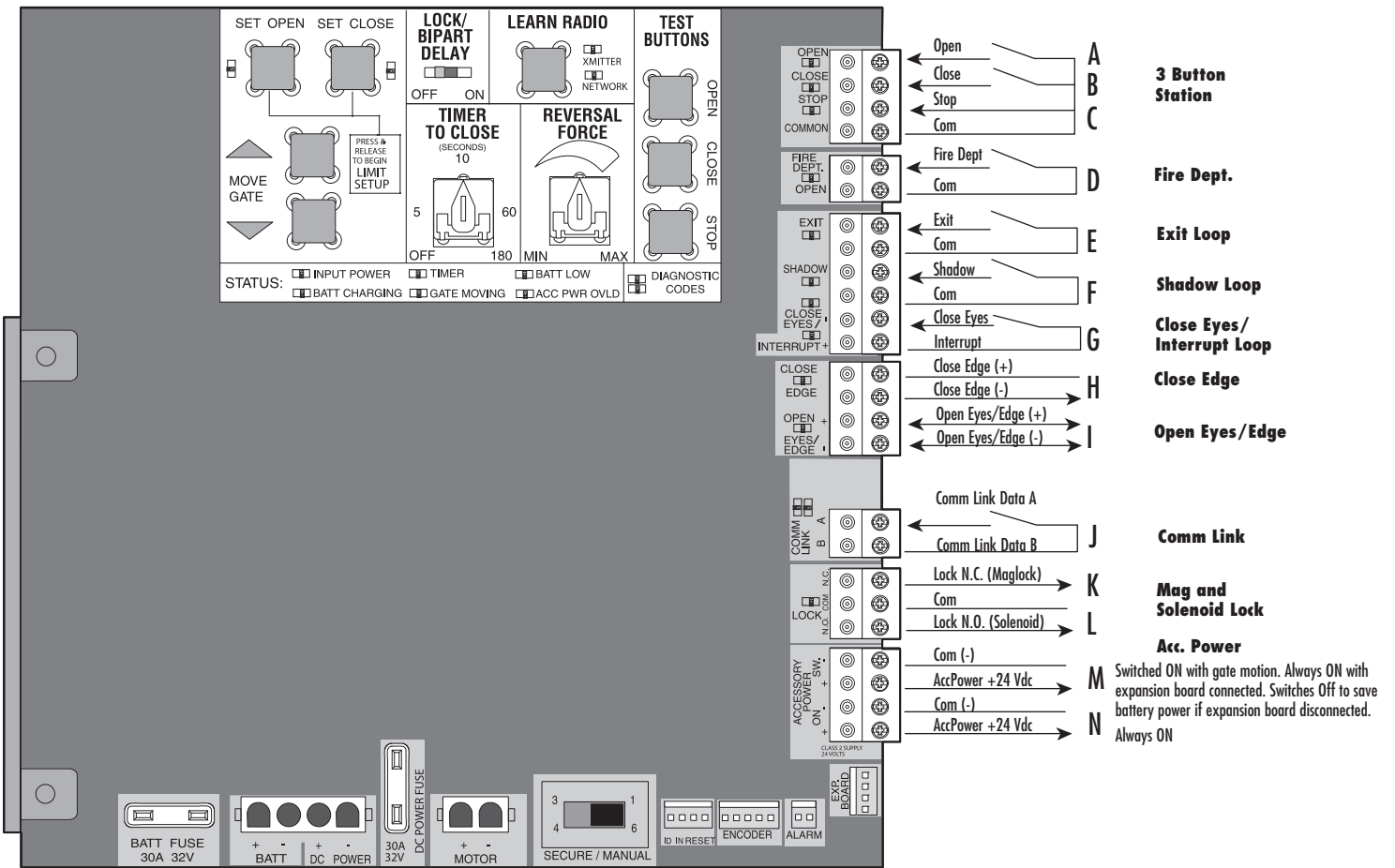

## DUAL GATE SETTINGS

**NOTE:** We recommend that all accessories and board configurations are set on the primary operator.

FEATURE	PRIMARY OPERATOR	SECONDARY OPERATOR
Timer-to-Close	Set the TTC dial to desired setting	OFF
Bi-Part Delay Switch	Bi-Part Delay: ON Tandem Mode: OFF Synchronized Close: ON	Bi-Part Delay: OFF Tandem Mode: OFF Synchronized Close: ON

ACCESSORY	PRIMARY OPERATOR	SECONDARY OPERATOR
Remote Controls	Program remote controls 1 to 50 to the primary operator.	Program remote controls 51 to 100 to the secondary operator
LiftMaster Internet Gateway	Program to primary operator.	
Garage Door Monitor	Program to primary operator.	



# ADDITIONAL FEATURES

## ACCESSORY FEATURES ON CONTROL BOARD

### ACCESSORY FEATURES ON CONTROL BOARD

<b>A</b>	<b>Open Input (&amp; common)</b> (3-Button Control Station, 4 terminals total)	Open command - opens a closed gate. Hard open (maintained switch overrides external safeties and resets alarm condition) If maintained, pauses Timer-to-Close at OPEN limit. Opens a closing gate and holds open an open gate (within line-of-sight).
<b>B</b>	<b>Close Input (&amp; common)</b> (3-Button Control Station, 4 terminals total)	Close command - closes an open gate. Hard close (maintained switch overrides external safeties and resets alarm condition within line-of-sight)
<b>C</b>	<b>Stop Input (&amp; common)</b> (3-Button Control Station, 4 terminals total)	Stop command - stops a moving gate. Hard stop (maintained switch overrides Open and Close commands and resets alarm condition) If maintained, pauses Timer-to-Close at OPEN limit. Overrides Open and Close commands (within line-of-sight).
<b>D</b>	<b>Fire Dept Open Input</b> (2 terminals)	Acts as hard open. Maintained input overrides (ignores) external safeties (photoelectric sensor and edge), pauses Timer-to-Close momentary input logic as single button control and safeties remain active, re-enables Timer-to-Close.
<b>E</b>	<b>Exit Loop Input</b> (2 terminals)	Open command - opens a closed gate. Soft open (maintained switch does not override external safeties and does not reset alarm condition) If maintained, pauses Timer-to-Close at OPEN limit. Opens a closing gate and holds open an open gate.
<b>F</b>	<b>Shadow Loop Input</b> (2 terminals)	Loop detector connection when loop is positioned under gate. <ul style="list-style-type: none"><li>- Holds open gate at open limit</li><li>- Disregarded at CLOSE limit and during gate motion</li><li>- Pauses Timer-to-Close at OPEN limit</li></ul>
<b>G</b>	<b>CLOSE EYES/Interrupt Loop Input</b> (2 terminals)	CLOSE EYES/Interrupt Loop detector connection when loop is along the side of the gate. <ul style="list-style-type: none"><li>- Holds open gate at open limit</li><li>- Stops and reverses a closing gate to open limit</li><li>- Pauses Timer-to-Close at OPEN limit</li></ul> Close Direction Photoelectric Sensors, IR, or Infra-red detector wired to CLOSE EYES Input, disregarded during gate opening. Pulsed Photoelectric Sensors = monitored device putting out a pulse train when unblocked. Photoelectric Sensors, IR, Infra-red detector, contact opens fully with obstruction.
<b>H</b>	<b>Close Edge</b> (2 terminals)	Close Direction Edge Sensor to Close Safety Input, disregarded during gate opening
<b>I</b>	<b>Open Eyes/Edge</b> (2 terminals)	Open Direction Photoelectric Sensors, IR, Infra-red detector wired or Edge Sensor to Close Entrapments Input, disregarded during gate closing, Pulsed Photoelectric Sensors = monitored device putting out a pulse train when unblocked. Photoelectric Sensors, IR, Infra-red detector, edge sensor = normally open contact, contact reverses for 2 seconds with obstruction.
<b>J</b>	<b>Comm Link</b> (2 terminals)	Commercial Link (two wires) - connects two operators together (primary-secondary wired connection)
<b>K</b>	<b>Lock Outputs: Maglock</b> (2 terminals, N.C. and COM)	Relay contact output, Normally - closed (N.C.) output for maglocks Relay activates prior to motor activation and during motor run. Relay is off when motor is off.
<b>L</b>	<b>Solenoid Lock &amp; Common</b> (2 terminals, N.O. and COM)	Normally - open (N.O.) output for solenoid locks Relay activates prior to motor activation and during motor run. Relay is off when motor is off.
<b>M</b>	<b>Accessory Power Out Switched, (2 terminals)</b>	24 Vdc voltage out to power accessories, will turn off when gate is not in motion to save battery power Always on if Expansion Board is connected.
<b>N</b>	<b>Accessory Power Out Un-switched, (2 terminals)</b>	24 Vdc voltage out to power accessories, always ON



# ADDITIONAL FEATURES

## EXPANSION BOARD OVERVIEW

### CAUTION

To AVOID damaging the circuit board, relays or accessories, DO NOT connect more than 42 Vdc (32 Vac) to the AUX relay contact terminal blocks.

**QUICK CLOSE Switch** OFF: No change to the gate's normal operation.  
ON: When CLOSE EYES/Interrupt loop is deactivated it causes an opening or a stopped gate to close (ignores the Timer-to-Close).

**AC FAIL OPEN/BATT Switch** OPEN: Loss of AC power will cause gate to immediately OPEN and remain OPEN until AC power is restored (enabling the Timer-to-Close).  
BATT: With loss of AC power, gate will remain in present position and operator is powered from batteries.

**LOW BATT/EXIT LOOP FAIL Switch**

- When AC power is OFF and battery voltage is low the gate will latch at a limit until AC power is restored or batteries voltage increases.
- Option select switch set to OPEN forces gate to latch at the OPEN limit if it is at the OPEN limit or on next open command until AC power is restored or battery voltage increases.
- Option select switch set to CLOSE forces gate to latch at CLOSE limit if at CLOSE limit or on next CLOSE command until AC power restored or battery voltage increases.
- Constant pressure on a hard command input overrides to open or close the gate.
- Low battery detect point = 22 V
- When set to OPEN, if the EXIT plug-in loop detector detects a fault, then the gate will open and remain open until fault is cleared. When set to CLOSE, then plug-in EXIT loop detector faults are ignored (EXIT loop is faulted and inoperative).

**ANTI-TAIL OPEN/CLOSE SELECTION switch** OFF: When CLOSE EYES/Interrupt loop is activated it causes a closing gate to stop and reverse.  
ON: When CLOSE EYES/Interrupt loop is activated it causes a closing gate to pause. Once the vehicle is clear the gate will continue to close.

**AUX RELAY switches** Set the AUX RELAY switches as needed to obtain the desired function:

AUX RELAY SETTING	SWITCH SETTINGS			AUX RELAY 1	AUX RELAY 2
	1	2	3		
Off (no feature selected)	OFF	OFF	OFF	Relay always off. Use this Aux Relay setting to conserve battery power.	Relay always off. Use this Aux Relay setting to conserve battery power.
Open Limit Switch	OFF	OFF	ON	Energizes at open limit. Use with SAMS (Sequenced Access Management System, jointly with barrier gate)	Energizes when at open limit. Use with SAMS (Sequenced Access Management System, jointly with barrier gate)
Close Limit Switch	OFF	ON	OFF	Energizes when not at close limit. Connect "Gate Close/Secure" indicator (e.g. light).	Energizes when not at close limit. Connect "Gate Not Closed/Secure" indicator (e.g. light).
Gate Motion	OFF	ON	ON	Energizes when motor is on (gate in motion). Connect "Gate In Motion" indicator (e.g. warning light or sounder).	Energizes when motor is on (gate in motion). Connect "Gate In Motion" indicator (e.g. warning light or sounder).
Pre-Motion Delay	ON	OFF	OFF	Energizes 3 seconds before gate motion and remains energized during gate motion. Connect "Gate In Motion" indicator (e.g. warning light or sounder).	Not used.
Power	ON	ON	OFF	Energizes when AC power or solar power is present. There is approximately a 10-12 second delay before relay cutoff, after AC shutdown.	Energizes when on battery power. There is approximately a 10-12 second delay before relay cutoff, after AC shutdown.
Tamper	ON	OFF	ON	Energizes if gate is manually tampered with by being pushed off of close limit. Connect alert (e.g. light or sounder).	Energizes if gate is manually tampered with by being pushed off of close limit. Connect alert (e.g. light or sounder).
Cycle Quantity Feedback*	ON	ON	ON	The OPEN, CLOSE, and STOP LEDs will blink out the cycle count (cycle count is stored on the control board). See below.	Not used.

### CYCLE COUNT

\* First, note the current Aux Relay switch positions. To determine the actual cycles that the gate operator has run (in thousands), set all three Aux Relay switches to the ON setting for Aux Relay 1. The Expansion Board's OPEN, CLOSE, and STOP LEDs will blink out the cycle count, with OPEN LED blinking 1000's, CLOSE LED blink 10,000's, STOP LED blinking 100,000's, and simultaneously all three LED's blink 1,000,000's (e.g. Open blinks 3 times, Close blinks 6 times, and Stop blinks once. Cycle count is 163,000.). Cycle count displayed is between 1,000 and 9,999,000 cycles. After servicing, set Aux Relay switches back to their appropriate positions. Cycle count cannot be reset or changed. If under 1,000 cycles the Open, Close, and Stop LEDs will turn on for 10 seconds, then turn off.

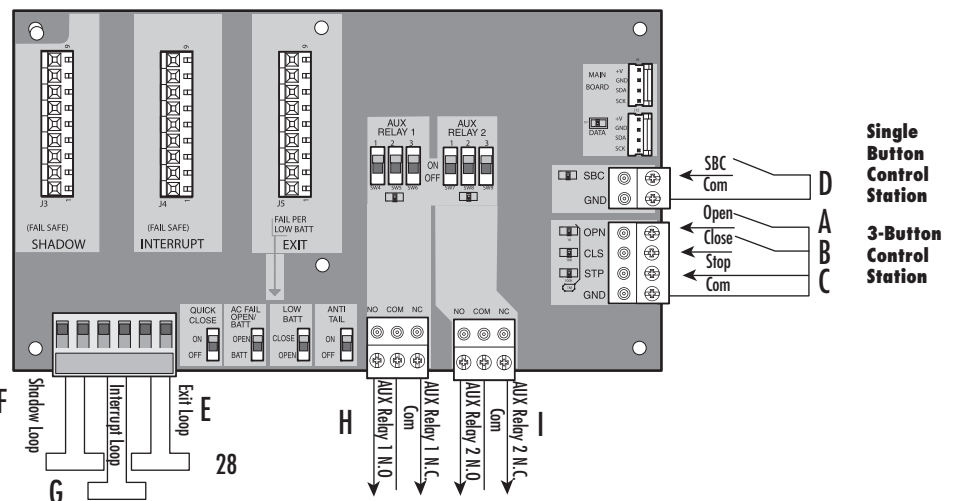

Single Button Control Station  
3-Button Control Station

# ADDITIONAL FEATURES

## ACCESSORY FEATURES ON EXPANSION BOARD

### ACCESSORY FEATURES ON EXPANSION BOARD

<b>A</b>	<b>Open Input (&amp; common)</b> (3-Button Control Station, 4 terminals total)	Open command - opens a closed gate. Soft close (maintained switch does not override external safeties and does not reset alarm condition) If maintained, pauses Timer-to-Close at OPEN limit. Opens a closing gate and holds open an open gate.
<b>B</b>	<b>Close Input (&amp; common)</b> (3-Button Control Station, 4 terminals total)	Close command - closes an open gate. Soft close (maintained switch does not override external safeties and does not reset alarm condition)
<b>C</b>	<b>Stop Input (&amp; common)</b> (3-PB station, 4 terminals total)	Stop command - stops a moving gate. Hard stop (maintained switch overrides Open and Close commands and resets alarm condition) If maintained, pauses Timer-to-Close at OPEN limit. Overrides an Open or Close command.
<b>D</b>	<b>Single Button Control, SBC</b> (2 terminals)	Gate command sequence - Open, Stop, Close, Stop, ... Soft open (maintained switch does not override external safeties and does not reset alarm condition)
<b>E</b>	<b>Exit Loop Input</b> (2 terminals)	Loop wire connection for plug-in loop detector when loop is inside secured area near gate. Open command - opens a closed gate. Soft open (maintained switch does not override external safeties and does not reset alarm condition) If maintained, pauses Timer-to-Close at OPEN limit. Opens a closing gate and holds open an open gate.
<b>F</b>	<b>Shadow Loop Input</b> (2 terminals)	Loop wire connection for plug-in loop detector when loop is along side gate. - Holds open gate at open - Disregarded at Close limit and during gate motion - Pauses Timer-to-Close at Open Limit
<b>G</b>	<b>Interrupt Loop Input</b> (2 terminals)	Loop wire connection for plug-in loop detector when loop is positioned under gate. - Holds open gate at open - Stops and reverses a closing gate - Pauses Timer-to-Close at Open Limit
<b>H</b>	<b>AUX Relay #1</b>	Normally - open and normally - closed relay contacts to control external devices, Function of relay contact activation determined by AUX Relay #1 option switch settings. (For connection of Class 2, low voltage (<32 V), DC or AC, max 5 Amps, power sources only)
<b>I</b>	<b>AUX Relay #2</b>	Normally-open and normally-closed relay contacts to control external devices, Function of relay contact activation determined by AUX Relay #2 option switch settings. (For connection of Class 2, low voltage (<32 V), DC or AC, max 5 Amps, power sources only)

### DUAL GATE SETTINGS

**NOTE:** We recommend that all accessories and board configurations are set on the primary operator.

FEATURE	PRIMARY OPERATOR	SECONDARY OPERATOR
QUICK CLOSE Switch	ON	OFF
ANTI-TAIL Switch	ON	OFF
LOW BATT Switch	Battery Fail OPEN: OPEN Battery Fail CLOSE: CLOSE	Battery Fail OPEN: OPEN Battery Fail CLOSE: CLOSE
AC FAIL OPEN/BATT Switch	OPEN	BATT

### SAMS WIRING WITH RELAYS NOT ENERGIZED

#### AUX RELAY WIRING EXAMPLE

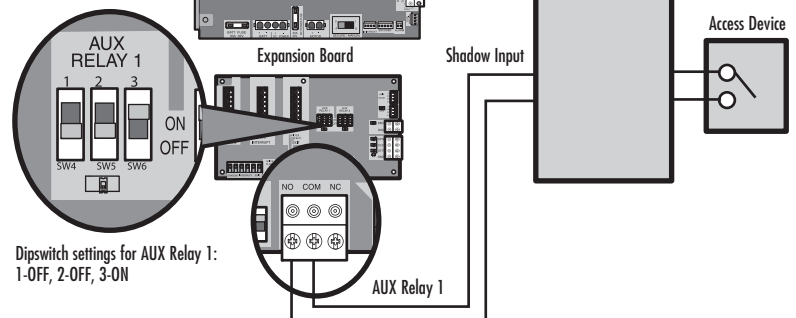
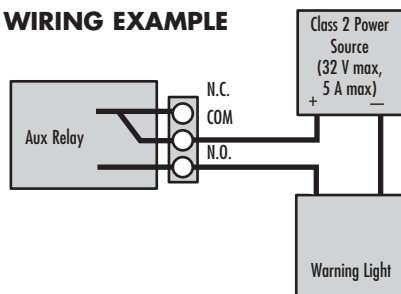

### LIMIT SETUP WITH A REMOTE CONTROL

To set the limits using a remote control, first you will need a 3-button remote control that has been programmed for OPEN, CLOSE, and STOP. Refer to the Programming section.

#### INITIAL LIMITS AND FORCE ADJUSTMENT

For dual gate applications the limits will have to be set for each operator. The gate **MUST** be attached to the operator before setting the limits and force.

Ensure the gate is closed.

- 1 Press and release the SET OPEN and SET CLOSE buttons simultaneously to enter limit setting mode.
- 2 Press and hold the OPEN or CLOSE button on the remote control until the gate reaches the desired open position. The gate can be jogged back and forth using the OPEN and CLOSE buttons on the remote control.
- 3 Once the gate is in the desired open position, press and release the STOP button on the remote control.
- 4 Press and release the OPEN button on the remote control again to set the open limit.
- 5 Press and hold the CLOSE or OPEN button on the remote control until the gate reaches the desired close position. The gate can be jogged back and forth using the OPEN and CLOSE buttons on the remote control.
- 6 Once the gate is in the desired close position, press and release the STOP button on the remote control.
- 7 Press and release the CLOSE button on the remote control again to set the close limit.
- 8 Cycle the gate open and close. This automatically sets the force.

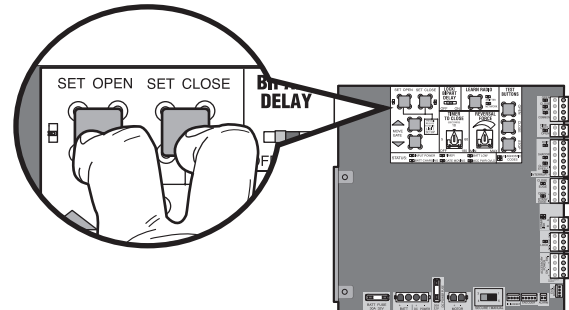

3-Button Remote Control programmed for OPEN, CLOSE, and STOP

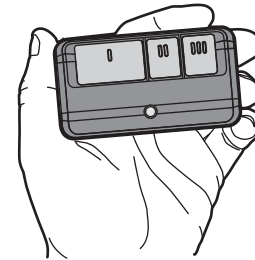

When limits are set properly the operator will automatically exit limit setting mode.

### LIMIT SETUP WITH A REMOTE CONTROL

#### ADJUST THE LIMITS

If the limits have already been set the operator will exit the limit setting mode after resetting each limit.

#### Set the Close Limit Only

- 1 Press and release the SET OPEN and SET CLOSE buttons simultaneously to enter limit setting mode.
- 2 Press and hold the CLOSE button on the remote control until the gate reaches the desired close position. The gate can be jogged back and forth using the OPEN and CLOSE buttons on the remote control.
- 3 Once the gate is in the desired close position, press and release the STOP button on the remote control.
- 4 Press and release the CLOSE button on the remote control again to set the close limit.

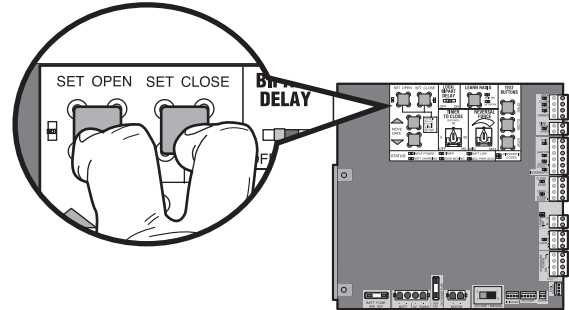

When the close limit is set properly the operator will automatically exit limit setting mode.

3-Button Remote Control programmed for OPEN, CLOSE, and STOP

#### Set the Open Limit Only

- 1 Press and release the SET OPEN and SET CLOSE buttons simultaneously to enter limit setting mode.
- 2 Press and hold the OPEN button on the remote control until the gate reaches the desired open position. The gate can be jogged back and forth using the OPEN and CLOSE buttons on the remote control.
- 3 Once the gate is in the desired open position, press and release the STOP button on the remote control.
- 4 Press and release the OPEN button on the remote control again to set the open limit.

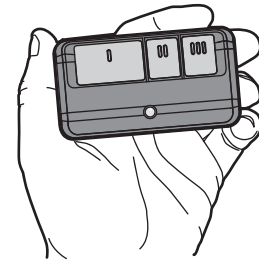

When the open limit is set properly the operator will automatically exit limit setting mode.

# ADDITIONAL FEATURES

## GATE OPERATOR SETUP EXAMPLES

### GATE OPERATOR SETUP EXAMPLES

The following are example setups for the gate operator. Your specific site requirements may be different. Always setup the operator system to the site requirements, including all necessary secondary entrapment protection systems. **NOTE:** We recommend that all accessories and board configurations are set on the primary operator.

**RESIDENTIAL SMALL:** One to four residential homes sharing a gated entrance/exit, allowing vehicle access trumps security concerns

**RESIDENTIAL LARGE:** A residential community (more than four homes) having one or more gated entrances/exits, allowing vehicle access trumps security concerns

**COMMERCIAL:** Business site where security (gate closed) is important

**INDUSTRIAL:** Large business site where security is required

Setting	RESIDENTIAL SMALL	RESIDENTIAL LARGE	COMMERCIAL	INDUSTRIAL
<b>Secure – Manual switch setting</b>	Set to MANUAL. If a fault occurs, residents can manually move gate.	Set to MANUAL. If a fault occurs, residents can manually move gate.	Set to SECURE. If a fault occurs, use disconnect and manually move gate.	Set to SECURE. If a fault occurs, use disconnect and manually move gate.
<b>Quick Close switch setting</b>	Normally set to OFF. Normal gate close (timer or control).	Normally set to OFF. Normal gate close (timer or control).	Normally set to OFF. Normal gate close (timer or control).	Set to ON, so that gate closes immediately after vehicle passes the CLOSE EYES/Interrupt loop.
<b>AC Fail Open switch setting</b>	Normally set to BATT. Run on battery if AC power fails.	Normally set to BATT. For local jurisdiction requirement, set to OPEN so that gate immediately opens upon AC power fail.	Normally set to BATT. Run on battery if AC power fails.	Normally set to BATT. Run on battery if AC power fails.
<b>Low Battery switch setting</b>	Normally set to OPEN. If powered from battery and battery is low, gate stays open.	Normally set to OPEN. If powered from battery and battery is low, gate stays open.	Normally set to CLOSE. If powered from battery and battery is low, gate stays close.	Normally set to CLOSE. If powered from battery and battery is low, gate stays close.
<b>Anti-Tail switch setting</b>	Normally set to OFF. CLOSE EYES/Interrupt loop reverses a closing gate.	Normally set to OFF. CLOSE EYES/Interrupt loop reverses a closing gate.	Set to ON. In attempt to prevent vehicle tail-gating, CLOSE EYES/Interrupt loop pauses a closing gate.	Set to ON. In attempt to prevent vehicle tail-gating, CLOSE EYES/Interrupt loop pauses a closing gate.
<b>Bipart Delay switch setting</b>	For DUAL-GATE site, set to ON for gate that delays upon opening	For DUAL-GATE site, set to ON for gate that delays upon opening	For DUAL-GATE site, set to ON for gate that delays upon opening	For DUAL-GATE site, set to ON for gate that delays upon opening
<b>Aux Relay Out – Open Limit Switch</b>	Typically not required.	Use with SAMS (Sequence Access Management System)	1) Use with SAMS (Sequence Access Management System) 2) Connect "Gate Open" indicator (e.g. light)	1) Use with SAMS (Sequence Access Management System) 2) Connect "Gate Open" indicator (e.g. light)
<b>Aux Relay Out – Close Limit Switch</b>	Typically not required.	Typically not required.	Connect "Gate Close/Secure" indicator (e.g. light)	Connect "Gate Close/Secure" indicator (e.g. light)
<b>Aux Relay Out – Gate Motion</b>	Attach alert signal (audible or visual alert system)	Attach alert signal (audible or visual alert system)	Attach alert signal (audible or visual alert system)	Attach alert signal (audible or visual alert system)
<b>Aux Relay Out – Pre-Motion Delay (Expansion Board Inputs)</b>	Attach alert signal (audible or visual alert system)	Attach alert signal (audible or visual alert system)	Attach alert signal (audible or visual alert system)	Attach alert signal (audible or visual alert system)
<b>Aux Relay Out – Power</b>	Attach visual alert to know when system is charging batteries (i.e. not running on batteries)	Attach visual alert to know when system is charging batteries (i.e. not running on batteries)	Attach visual alert to know when system is charging batteries (i.e. not running on batteries)	Attach visual alert to know when system is charging batteries (i.e. not running on batteries)
<b>Aux Relay Out – Tamper (Slide Gates Only)</b>	Attach alert signal (audible or visual alert system) to indicate if gate is manually tampered with by being pushed off of close limit	Attach alert signal (audible or visual alert system) to indicate if gate is manually tampered with by being pushed off of close limit	Attach alert signal (audible or visual alert system) to indicate if gate is manually tampered with by being pushed off of close limit	Attach alert signal (audible or visual alert system) to indicate if gate is manually tampered with by being pushed off of close limit
<b>Cycle Quantity Feedback</b>	Use during servicing only to determine operator cycles	Use during servicing only to determine operator cycles	Use during servicing only to determine operator cycles	Use during servicing only to determine operator cycles
<b>Fire Dept Open input</b>	Typically not required.	Connect emergency access system (Knox box switch, SOS system, etc.)	Typically not required.	Typically not required.
<b>Heater Option</b>	Suggested use if outside temperature remain below 0°F (-20°C).	Suggested use if outside temperature remain below 0°F (-20°C).	Suggested use if outside temperature remain below 0°F (-20°C).	Suggested use if outside temperature remain below 0°F (-20°C).

# ADDITIONAL FEATURES

## LIFTMASTER INTERNET GATEWAY

To program the operator to the LiftMaster Internet Gateway:

### USING THE LEARN BUTTON ON THE OPERATOR'S CONTROL BOARD

- 1 Connect the ethernet cable to the LiftMaster Internet Gateway and the router.
- 2 Connect power to the LiftMaster Internet Gateway.
- 3 Create an online account by visiting [www.myliftmaster.com](http://www.myliftmaster.com).
- 4 Register the LiftMaster Internet Gateway.
- 5 Use an internet enabled computer or smartphone to add devices. The LiftMaster Internet Gateway will stay in learn mode for three minutes.
- 6 Press the Learn button twice on the primary operator (the operator will beep as it enters learn mode). The LiftMaster Internet Gateway will pair to the operator if it is within range and the operator will beep if programming is successful.

### OR USING THE RESET SWITCH ON THE OPERATOR

- 1 Connect the ethernet cable to the LiftMaster Internet Gateway and the router.
- 2 Connect power to the LiftMaster Internet Gateway.
- 3 Create an online account by visiting [www.myliftmaster.com](http://www.myliftmaster.com).
- 4 Register the LiftMaster Internet Gateway.
- 5 Use an internet enabled computer or smartphone to add devices. The LiftMaster Internet Gateway will stay in learn mode for three minutes.
- 6 Ensure gate is closed.
- 7 Give the operator an OPEN command.
- 8 Within 30 seconds, when the gate is at the open limit toggle the reset switch 3 times (on primary gate) to put primary operator into High Band Learn Mode (the operator will beep as it enters learn mode). The LiftMaster Internet Gateway will pair to the operator if it is within range and the operator will beep if programming is successful.

The status as shown by the LiftMaster Internet Gateway app will be either "open" or "closed". The gate operator can then be controlled through the LiftMaster Internet Gateway app.

# MAINTENANCE

## MAINTENANCE CHART + BATTERIES + DRIVE CHAIN

### MAINTENANCE CHART

**Disconnect all power (AC, solar, battery) to the operator before servicing.** The operator's AC Power switch ONLY turns off AC power to the control board and DOES NOT turn off battery power. ALWAYS disconnect the batteries to service the operator.

DESCRIPTION	TASK	CHECK AT LEAST ONCE EVERY		
		MONTH	6 MONTHS	3 YEARS
Entrapment Protection Devices	Check and test for proper operation	X		
Warning Signs	Make sure they are present	X		
Manual Disconnect	Check and test for proper operation		X	
Drive Chain and Sprockets	Check for excessive slack and lubricate	X		
Belt and Pulley	Check for excessive slack, wear or damage		X	
Gate	Inspect for wear or damage	X		
Accessories	Check all for proper operation		X	
Electrical	Inspect all wire connections		X	
Chassis Mounting Bolts	Check for tightness		X	
Operator	Inspect for wear or damage		X	
Batteries	Replace			X

#### NOTES:

- Severe or high cycle usage will require more frequent maintenance checks.
- Limits may have to be reset after any major drive chain adjustments.
- If lubricating chain, use only lithium spray. Never use grease or silicone spray.

- It is suggested that while at the site voltage readings be taken at the operator. Using a digital voltmeter, verify that the incoming voltage to the operator it is within ten percent of the operator's rating.

### BATTERIES

Batteries will degrade over time depending on temperature and usage. For best performance, the batteries should be replaced every 3 years. Use only LiftMaster part 29-NP712 for replacement batteries. The operator comes with two 7AH batteries. Two 33AH (A12330SGLPK) may be used in place of the 7AH batteries. The batteries contain lead and need to be disposed of properly. Batteries do not perform well in extremely cold temperatures.

The operator alarm will beep 3 times with a command if the battery is low.

### DRIVE CHAIN

Over time, the drive chain on the operator will stretch and need to be tightened. To tighten the drive chain adjust either of the two chain eye bolts.

**NOTE:** The chain should have no more than 1 inch of sag for every 10 feet of chain length.

# TROUBLESHOOTING

## CONTROL BOARD LEDS

The control board is equipped with many LEDs that have a variety of functions. The control board LEDs indicate the status of the operator, assist with programming, and diagnose potential problems with the operator.

**NOTE:** When cycling or disconnecting power (ac/dc) to the control board, it is recommended that you unplug the J15 plug.

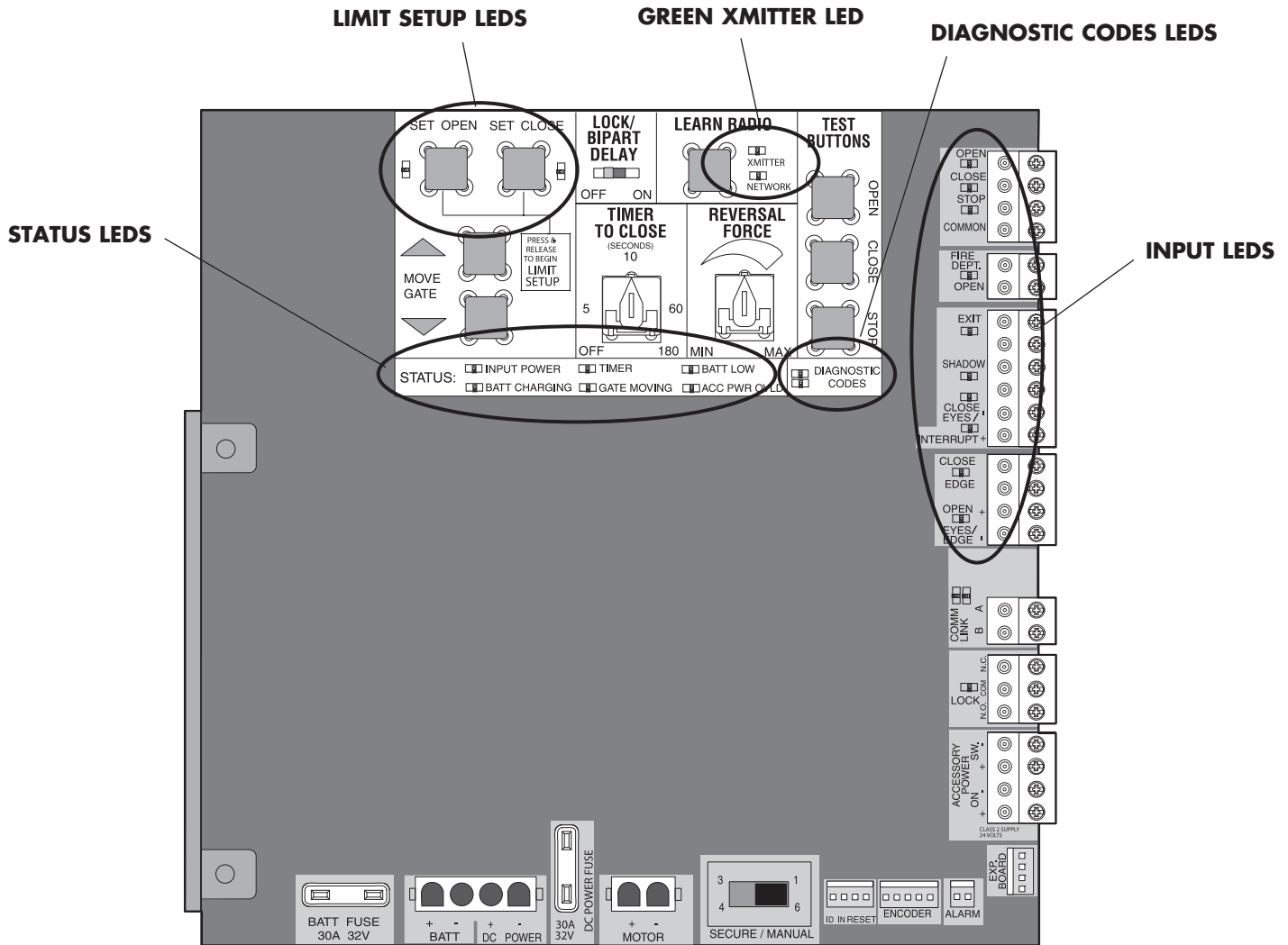

LIMIT SETUP LEDS			
SET OPEN LED	SET CLOSE LED	OPERATOR MODE	EXPLANATION
BLINKING	BLINKING	NORMAL MODE	Limits are not set.
OFF	OFF	NORMAL MODE	Limits are set.
BLINKING	BLINKING	LIMIT SETTING MODE	Limits are not set.
BLINKING	ON	LIMIT SETTING MODE	Open limit is not set.
ON	BLINKING	LIMIT SETTING MODE	Close limit is not set.
ON	ON	LIMIT SETTING MODE	Limits are set.

GREEN XMITTER LED	
XMITTER LED	EXPLANATION
OFF	No remote control activity, normal operation.
ON	Programming mode active.
FAST	Recognized remote control signal.
FASTER	Unrecognized remote control signal.
FASTEST	Remote controls are being erased.



### CONTROL BOARD LEDS

DIAGNOSTIC CODES LEDS					
YELLOW DIAGNOSTIC LED			RED DIAGNOSTIC LED		
# BLINKS	MEANING	CORRECTION	# BLINKS	MEANING	CORRECTION
1 BLINK	Low Power Mode	(not an error)	2 BLINKS	Current Sense	Motor control circuit fault, replace control board
2 BLINKS	ID resistor failure	Check ID resistor wiring, clear limit settings and reset limits	3 BLINKS	FET Failure	Motor control circuit fault, replace control board
3 BLINKS	Exceeded Maximum Run Timer	Check gate travel, if necessary adjust force setting	4 BLINKS	RAM Failure	Memory failure, replace control board
5 BLINKS	RPM (obstruction)	Check for obstruction, if necessary adjust force setting	5 BLINKS	Flash Memory Failure	Memory failure, replace control board
6 BLINKS	Current (obstruction)	Check for obstruction, if necessary adjust force setting	6 BLINKS	EEPROM Failure	Memory failure, replace control board
7 BLINKS	Position failure	Check gate travel, clear limit settings and reset limits	7 BLINKS	Watchdog Failure	Controller failure, replace control board
12 BLINKS	Loop Error	One of the loops is in error. Refer to the loop detector to determine the error.	8 BLINKS	Brownout	Check power harness or line voltage
			9 BLINKS	Fail	Control Board failure
			10-14 BLINKS	Software Failure	Cycle power to the control board. If continues replace control board.

STATUS LEDS		
INPUT POWER	OFF	OFF state
	ON	AC charger or Solar power available
BATT CHARGING	OFF	Not charging
	ON	Trickle charge
	FAST BLINK	High current charge
	FASTER BLINK	Over voltage error
TIMER	OFF	The timer is disabled
	ON	The timer is enabled
	MEDIUM BLINK	The timer is running
	FAST BLINK	The timer is paused
	FASTER BLINK	The timer is cancelled
GATE MOVING	OFF	The gate is stopped
	ON	The gate is opening or closing
	FASTEST BLINK	The operator is in E2
BATT LOW	OFF	No battery error
	ON	Battery low error
	MEDIUM BLINK	Battery critically low error
	FAST BLINK	Battery disconnected error
	FASTEST BLINK	Charging, extreme temperature, or over voltage error
ACC PWR OVLD	OFF	OFF state
	ON	Accessory overload protector opened

INPUT LEDS		
OPEN INPUT	OFF	Input inactive
	ON	Input active
	BLINK	Input active on other operator
CLOSE INPUT	OFF	Input inactive
	ON	Input active
	BLINK	Input active on other operator
STOP INPUT	OFF	Input inactive
	ON	Input active
	BLINK	Input active on other operator
FIRE DEPT INPUT	OFF	Input inactive
	ON	Input active
	BLINK	Input active on other operator
OPEN SAFETY INPUT	OFF	Input inactive
	ON	Input active
	BLINK	Input active on other operator
CLOSE SAFETY INPUT	OFF	Input inactive
	ON	Input active
	BLINK	Input active on other operator

FAULT	POSSIBLE CAUSES	CORRECTIONS
<b>Operator does not run and diagnostic LED not on.</b>	<ul style="list-style-type: none"> <li>a) No power to control board</li> <li>b) Open fuse</li> <li>c) If on battery power only, low or dead batteries</li> <li>d) Defective control board</li> </ul>	<ul style="list-style-type: none"> <li>a) Check AC and battery power</li> <li>b) Check fuses</li> <li>c) Charge batteries by AC or solar power or replace batteries</li> <li>d) Replace defective control board</li> </ul>
<b>Control board powers up, but motor does not run.</b>	<ul style="list-style-type: none"> <li>a) Check DIAGNOSTIC LEDs</li> <li>b) Reset switch set to RESET</li> <li>c) Stop button active</li> <li>d) If on battery power only, low or dead batteries</li> <li>e) Open or Close input active</li> <li>f) Entrapment Protection Device active</li> <li>g) Vehicle loop detector or probe active</li> <li>h) Defective control board</li> </ul>	<ul style="list-style-type: none"> <li>a) Use Diagnostic code to identify issue</li> <li>b) Check Reset switch</li> <li>c) Check Stop button is not "stuck on"</li> <li>d) Charges batteries by AC or solar power or replace batteries</li> <li>e) Check all Open and Close inputs for a "stuck on" input</li> <li>f) Check all Entrapment Protection Device inputs for a "stuck on" sensor</li> <li>g) Check all vehicle detector inputs for a "stuck on" detector</li> <li>h) Replace defective control board</li> </ul>
<b>Relay clicks with command, but motor does not turn on.</b>	<ul style="list-style-type: none"> <li>a) Chain jammed</li> <li>b) Defective motor or motor wires</li> <li>c) Defective control board</li> </ul>	<ul style="list-style-type: none"> <li>a) Check chain. Use manual disconnect, manually move gate, and ensure gate moves easily limit to limit. Repair gate as needed.</li> <li>b) Inspect motor and motor wires for open wire, shorted wires, damage, etc. Else, replace motor.</li> <li>c) Replace defective control board.</li> </ul>
<b>Gate moves, but cannot set correct limits.</b>	<ul style="list-style-type: none"> <li>a) Gate does not move to a limit position</li> <li>b) Gate is too difficult to move</li> </ul>	<ul style="list-style-type: none"> <li>a) Use manual disconnect, manually move gate, and ensure gate moves easily limit to limit. Repair gate as needed.</li> <li>b) Gate must move easily and freely through its entire range, limit-to-limit. Repair gate as needed.</li> </ul>
<b>Gate does not fully open or fully close when setting limits.</b>	<ul style="list-style-type: none"> <li>a) Gate does not move to a limit position</li> <li>b) Gate is too difficult to move</li> </ul>	<ul style="list-style-type: none"> <li>a) Use manual disconnect, manually move gate, and ensure gate moves easily limit to limit. Repair gate as needed.</li> <li>b) Gate must move easily and freely through its entire range, limit-to-limit. Repair gate as needed.</li> </ul>
<b>Operator does not respond to a wired control/command (example: Open, Close, SBC, etc.)</b>	<ul style="list-style-type: none"> <li>a) Check DIAGNOSTIC LEDs</li> <li>b) Check Open and Close command input LEDs</li> <li>c) Stop button is active</li> <li>d) Reset switch is set to RESET</li> <li>e) If on battery power only, low or dead batteries</li> <li>f) Entrapment Protection Device active</li> <li>g) Vehicle loop detector or vehicle probe active</li> <li>h) Defective control board</li> </ul>	<ul style="list-style-type: none"> <li>a) Use Diagnostic code to identify issue</li> <li>b) Check all Open and Close inputs for a "stuck on" input</li> <li>c) Check Stop button is not "stuck on"</li> <li>d) Check Reset switch</li> <li>e) Charges batteries by AC or solar power or replace batteries</li> <li>f) Check all Entrapment Protection Device inputs for a "stuck on" sensor</li> <li>g) Check all vehicle detector inputs for a "stuck on" detector</li> <li>h) Replace defective control board</li> </ul>
<b>Operator does not respond to a wireless control or transmitter</b>	<ul style="list-style-type: none"> <li>a) Check DIAGNOSTIC LEDs</li> <li>b) Check XMITTER LED when wireless control is active</li> <li>c) Stop button is active</li> <li>d) Reset switch is set to RESET</li> <li>e) Poor radio reception</li> <li>f) Defective control board</li> </ul>	<ul style="list-style-type: none"> <li>a) Use Diagnostic code to identify issue</li> <li>b) Activate wireless control and check XMITTER LED is on. Re-learn wireless control/transmitter to control board. Replace wireless control as needed.</li> <li>c) Check Stop button is not "stuck on"</li> <li>d) Check Reset switch</li> <li>e) Check if similar wired control operates correctly. Check if wireless controls works properly when within a few feet of operator. Check operator's antenna and antenna wire. Check other wireless controls or devices.</li> <li>f) Replace defective control board</li> </ul>

FAULT	POSSIBLE CAUSES	CORRECTIONS
<b>Gate stops during travel and reverses immediately.</b>	<ul style="list-style-type: none"> <li>a) Check DIAGNOSTIC LEDs</li> <li>b) Inherent force obstruction detection</li> <li>c) External Entrapment Protection Device activation</li> <li>d) Control (Open, Close) becoming active</li> <li>e) Vehicle loop detector active</li> <li>f) Low battery voltage</li> </ul>	<ul style="list-style-type: none"> <li>a) Use Diagnostic code to identify issue</li> <li>b) Check for obstruction in gate's path or travel. Use manual disconnect, manually move gate, and ensure gate moves easily and freely through its entire range, limit-to-limit. Remove obstruction or repair gate as needed.</li> <li>c) Check all Entrapment Protection Device inputs for an active sensor</li> <li>d) Check all Open and Close inputs for an active input</li> <li>e) Check all vehicle detector inputs for an active detector</li> <li>f) Battery voltage must be 22.0 Vdc or higher. Charge batteries by AC or solar power or replace batteries</li> </ul>
<b>Gate opens, but will not close.</b>	<ul style="list-style-type: none"> <li>a) Check DIAGNOSTIC LEDs</li> <li>b) Open control active</li> <li>c) Close Entrapment Protection Device active</li> <li>d) Loss of AC power with AC FAIL set to OPEN</li> <li>e) Low battery with LOW BATT set to OPEN</li> <li>f) Fire Dept input active</li> </ul>	<ul style="list-style-type: none"> <li>a) Use Diagnostic code to identify issue</li> <li>b) Check all Open inputs for an active input</li> <li>c) Check all Entrapment Protection Device inputs for an active sensor</li> <li>d) Check AC power and AC Fail option setting</li> <li>e) Battery voltage must be 22.0 Vdc or higher. Charge batteries by AC or solar power or replace batteries</li> <li>f) Check Fire Dept input</li> </ul>
<b>Gate closes, but will not open.</b>	<ul style="list-style-type: none"> <li>a) Check DIAGNOSTIC LEDs</li> <li>b) Open Entrapment Protection Device active</li> <li>c) Vehicle loop detector active</li> <li>d) Low battery with LOW BATT option set to CLOSE</li> </ul>	<ul style="list-style-type: none"> <li>a) Use Diagnostic code to identify issue</li> <li>b) Check all Entrapment Protection Device inputs for an active sensor</li> <li>c) Check all vehicle detector inputs for an active detector</li> <li>d) Check if AC power is available. If no AC power, then running on batteries and battery voltage must be 22.0 Vdc or higher. Charge batteries by AC or solar power or replace batteries</li> </ul>
<b>Gate does not close from Timer-to-Close.</b>	<ul style="list-style-type: none"> <li>a) Timer-to-Close not set</li> <li>b) Open control active</li> <li>c) Close Entrapment Protection Device active</li> <li>d) Vehicle loop detector active</li> <li>e) Loss of AC power with AC FAIL set to OPEN</li> <li>f) Low battery with LOW BATT option set to OPEN</li> <li>g) Fire Dept input active</li> </ul>	<ul style="list-style-type: none"> <li>a) Check Timer-to-Close (TTC) setting</li> <li>b) Check all Open inputs for an active input</li> <li>c) Check all Entrapment Protection Device inputs for an active sensor</li> <li>d) Check all vehicle detector inputs for an active detector</li> <li>e) Check AC power and AC Fail option setting</li> <li>f) Check if AC power is available. If no AC power, then running on batteries and battery voltage must be 22.0 Vdc or higher. Charge batteries by AC or solar power or replace batteries</li> <li>g) Check Fire Dept input</li> </ul>
<b>Vehicle Exit loop activation does not cause gate to open.</b>	<ul style="list-style-type: none"> <li>a) Check DIAGNOSTIC LEDs</li> <li>b) Exit vehicle detector setup incorrectly</li> <li>c) Defective Exit loop detector or loop wire</li> <li>d) Low battery with LOW BATT option set to CLOSE</li> </ul>	<ul style="list-style-type: none"> <li>a) Use Diagnostic code to identify issue</li> <li>b) Review Exit loop detector settings. Adjust settings as needed.</li> <li>c) Check Exit loop wire. Replace defective Exit loop detector.</li> <li>d) Check if AC power is available. If no AC power, then running on batteries and battery voltage must be 22.0 Vdc or higher. Charge batteries by AC or solar power or replace batteries</li> </ul>
<b>CLOSE EYES/Interrupt loop does not cause gate to stop and reverse.</b>	<ul style="list-style-type: none"> <li>a) Check DIAGNOSTIC LEDs</li> <li>b) Vehicle detector setup incorrectly</li> <li>c) Defective vehicle loop detector or loop wire</li> </ul>	<ul style="list-style-type: none"> <li>a) Use Diagnostic code to identify issue. Check Anti-Tail gate switch.</li> <li>b) Review Interrupt loop detector settings. Adjust settings as needed</li> <li>c) Check Interrupt loop wire. Replace defective Interrupt loop detector</li> </ul>
<b>Vehicle Shadow loop does not keep gate at open limit.</b>	<ul style="list-style-type: none"> <li>a) Check DIAGNOSTIC LEDs</li> <li>b) Vehicle detector setup incorrectly</li> <li>c) Defective vehicle loop detector or loop wire</li> </ul>	<ul style="list-style-type: none"> <li>a) Use Diagnostic code to identify issue</li> <li>b) Review Shadow loop detector settings. Adjust settings as needed</li> <li>c) Check Shadow loop wire. Replace defective Shadow loop detector</li> </ul>
<b>Obstruction in gates path does not cause gate to stop and reverse</b>	<ul style="list-style-type: none"> <li>a) Force setting too high</li> </ul>	<ul style="list-style-type: none"> <li>a) Adjust force setting. Retest that obstruction in gate's path causes gate to stop and reverse direction.</li> </ul>

FAULT	POSSIBLE CAUSES	CORRECTIONS
<b>Photoelectric sensor does not stop or reverse gate.</b>	<ul style="list-style-type: none"> <li>a) Incorrect photoelectric sensor wiring</li> <li>b) Defective photoelectric sensor</li> </ul>	<ul style="list-style-type: none"> <li>a) Check photoelectric sensor wiring. Retest that obstructing photoelectric sensor causes moving gate to stop, and may reverse direction. Check Anti-Tail gate switch.</li> <li>b) Replace defective photoelectric sensor. Retest that obstructing photoelectric sensor causes moving gate to stop, and may reverse direction.</li> </ul>
<b>Edge sensor does not stop or reverse gate.</b>	<ul style="list-style-type: none"> <li>a) Incorrect edge sensor wiring</li> <li>b) Defective edge sensor</li> </ul>	<ul style="list-style-type: none"> <li>a) Check edge sensor wiring. Retest that activating edge sensor causes moving gate to stop and reverse direction.</li> <li>b) Replace defective edge sensor. Retest that activating edge sensor causes moving gate to stop and reverse direction.</li> </ul>
<b>Alarm sounds for 5 minutes or alarm sounds with a command.</b>	<ul style="list-style-type: none"> <li>a) Double entrapment occurred</li> </ul>	<ul style="list-style-type: none"> <li>a) Check for cause of entrapment (obstruction) detection and correct. Toggle the reset switch to shut off alarm and reset the operator.</li> </ul>
<b>Alarm beeps three times with a command.</b>	<ul style="list-style-type: none"> <li>a) Low battery with loss of AC/solar power</li> </ul>	<ul style="list-style-type: none"> <li>a) Check if AC power is available. If no AC power, then running on batteries and battery voltage must be 22.0 Vdc or higher. Charge batteries by AC or solar power or replace batteries</li> </ul>
<b>On dual-gate system, one gate is not commanding the other.</b>	<ul style="list-style-type: none"> <li>a) Defective or incorrect operator-to-operator wiring</li> <li>b) Incorrect operator-to-operator wireless learning</li> </ul>	<ul style="list-style-type: none"> <li>a) Check operator-to-operator wiring.</li> <li>b) Relearn the wireless network of one operator to the other operator.</li> </ul>
<b>On dual-gate system, incorrect gate opens first or closes first.</b>	<ul style="list-style-type: none"> <li>a) Incorrect Bipart switch setting</li> </ul>	<ul style="list-style-type: none"> <li>a) Change setting of both operator's Bipart switch settings. One operator should have Bipart switch ON (operator that opens first) and the other operator should have Bipart switch OFF (operator that opens second)</li> </ul>
<b>Expansion board function not controlling gate.</b>	<ul style="list-style-type: none"> <li>a) Defective main board to expansion board wiring</li> <li>b) Incorrect input wiring to expansion board</li> <li>c) Defective expansion board or defective main board</li> </ul>	<ul style="list-style-type: none"> <li>a) Check main board to expansion board wiring. If required, replace wire cable.</li> <li>b) Check wiring to all inputs on expansion board.</li> <li>c) Replace defective expansion board or defective main board</li> </ul>
<b>Maglock not working correctly.</b>	<ul style="list-style-type: none"> <li>a) Maglock wired incorrectly</li> </ul>	<ul style="list-style-type: none"> <li>a) Check that Maglock is wired to N.O. and COM terminals. Check that Maglock has power (do not power maglock from control board accessory power terminals). If shorting lock's NO and COM wires does not activate Maglock, then replace Maglock or Maglock wiring</li> </ul>
<b>Solenoid lock not working correctly.</b>	<ul style="list-style-type: none"> <li>a) Solenoid wired incorrectly</li> </ul>	<ul style="list-style-type: none"> <li>a) Check that Solenoid is wired to N.C. and COM terminals. Check that Solenoid has power (do not power solenoid from control board accessory power terminals). If shorting lock's NC and COM wires does not activate Solenoid, then replace Solenoid lock or Solenoid wiring</li> </ul>
<b>Switched (SW) Accessory power remaining on.</b>	<ul style="list-style-type: none"> <li>a) Main control board is not going to low power mode.</li> </ul>	<ul style="list-style-type: none"> <li>a) Photoelectric sensor inputs may be active.</li> </ul>
<b>Accessories connected to Switch (SW) Accessory power not working correctly, turning off, or resetting.</b>	<ul style="list-style-type: none"> <li>a) Main control board is going to low power mode.</li> </ul>	<ul style="list-style-type: none"> <li>a) With expansion board disconnected and running on batteries (no AC power or solar power available), main board will go into low power mode. Move accessory power to Accy Power ON terminals (+, -). Connect expansion board to prevent low power mode.</li> </ul>
<b>Accessories connected to Accessory power not working correctly, turning off, or resetting.</b>	<ul style="list-style-type: none"> <li>a) Accessory power protector active</li> <li>b) Defective control board</li> </ul>	<ul style="list-style-type: none"> <li>a) Disconnect all accessory powered devices and measure accessory power voltage (should be 23 – 30 Vdc). If voltage is correct, connect accessories one at a time, measuring accessory voltage after every new connection.</li> <li>b) Replace defective control board</li> </ul>

FAULT	POSSIBLE CAUSES	CORRECTIONS
<b>Quick Close not working correctly.</b>	<ul style="list-style-type: none"> <li>a) Quick Close setting incorrect</li> <li>b) CLOSE EYES/Interrupt loop detector or loop wire defective</li> <li>c) Defective Expansion board</li> </ul>	<ul style="list-style-type: none"> <li>a) Check that Quick Close setting is ON</li> <li>b) Check operation of CLOSE EYES/Interrupt Loop detector</li> <li>c) Replace defective Expansion board</li> </ul>
<b>Anti-Tailgating not working correctly.</b>	<ul style="list-style-type: none"> <li>a) Anti-Tail setting incorrect</li> <li>b) CLOSE EYES/Interrupt loop detector or loop wire defective</li> <li>c) Defective Expansion board</li> </ul>	<ul style="list-style-type: none"> <li>a) Check that Anti-Tail setting is ON</li> <li>b) Check operation of CLOSE EYES/Interrupt Loop detector</li> <li>c) Replace defective Expansion board</li> </ul>
<b>AUX Relay not working correctly.</b>	<ul style="list-style-type: none"> <li>a) AUX Relay setting incorrect</li> <li>b) AUX Relay wiring incorrect</li> <li>c) Defective Expansion board</li> </ul>	<ul style="list-style-type: none"> <li>a) Check AUX Relay switches settings</li> <li>b) Check that wiring is connected to either N.O. and COM or to N.C. and COM.</li> <li>c) Set AUX Relay to another setting and test. Replace defective expansion board.</li> </ul>

# REPAIR PARTS

## INDIVIDUAL PARTS

ITEM	PART NUMBER	DESCRIPTION	NOT SHOWN	
1	K73-34718-2	Chassis	K94-36250	Battery Harness (for 7AH batteries)
2	K77-36480	Operator Cover with labels, keys, and lock assembly	K94-36531	Wiring Harness with ID Resistor 30 Amp Fuses
3	K76-34697	APS Encoder, 24V	1941240D	#41 Chain (10 feet)
4	K16-GT2-7	Timing Belt, 3M	1950307	#41 Master Link
5	K17-36530	Gear Reducer Pulley and Motor Pulley	77-50382	Hardware: Chain Eye-bolts with Nuts, Chain Bracket (2), Crank Handle
6	K15-41B17LKGH	Output Sprocket		
7	K32-34669-1	Gear Reducer	Q003	Chain Bolt
8	K204C0211	Toroid Transformer	Q004	Chain Bracket
9	K1A6408	APE Assembly with plastic tray, RPM board with mounting hardware	K80-36544	Vent Plug
10	K52C0481	Bridge Rectifier	K74-30762	Two 7AH batteries
11	K1D6597-1CC	Main Board with heat sink	K94-36596	Battery Harness (for 33AH batteries)
12	K1D6686CC	Expansion Board	K75-34986-2	7AH Heater/Battery Bracket
13	K76-34728	EMI Board with 120V receptacles and AC power switch		
14	K77-36541	Antenna		
15	K76-36398	Motor, 1/2 HP, 24 Vdc		
16	K77-36542	Electrical Box with junction box		
17	K180A0357	Reset Switch		
18	K94-35152	Alarm with harness		
19	K75-36260	Lock and Keys		
20	Q118	Keys		
21	K13-34729	Dust Guard		
22	Q013	Idler Pulley with hardware		
23	29-NP712	Battery, 7AH, 12 Vdc		
24	K10-34758-2	Battery Tray		

# REPAIR PARTS

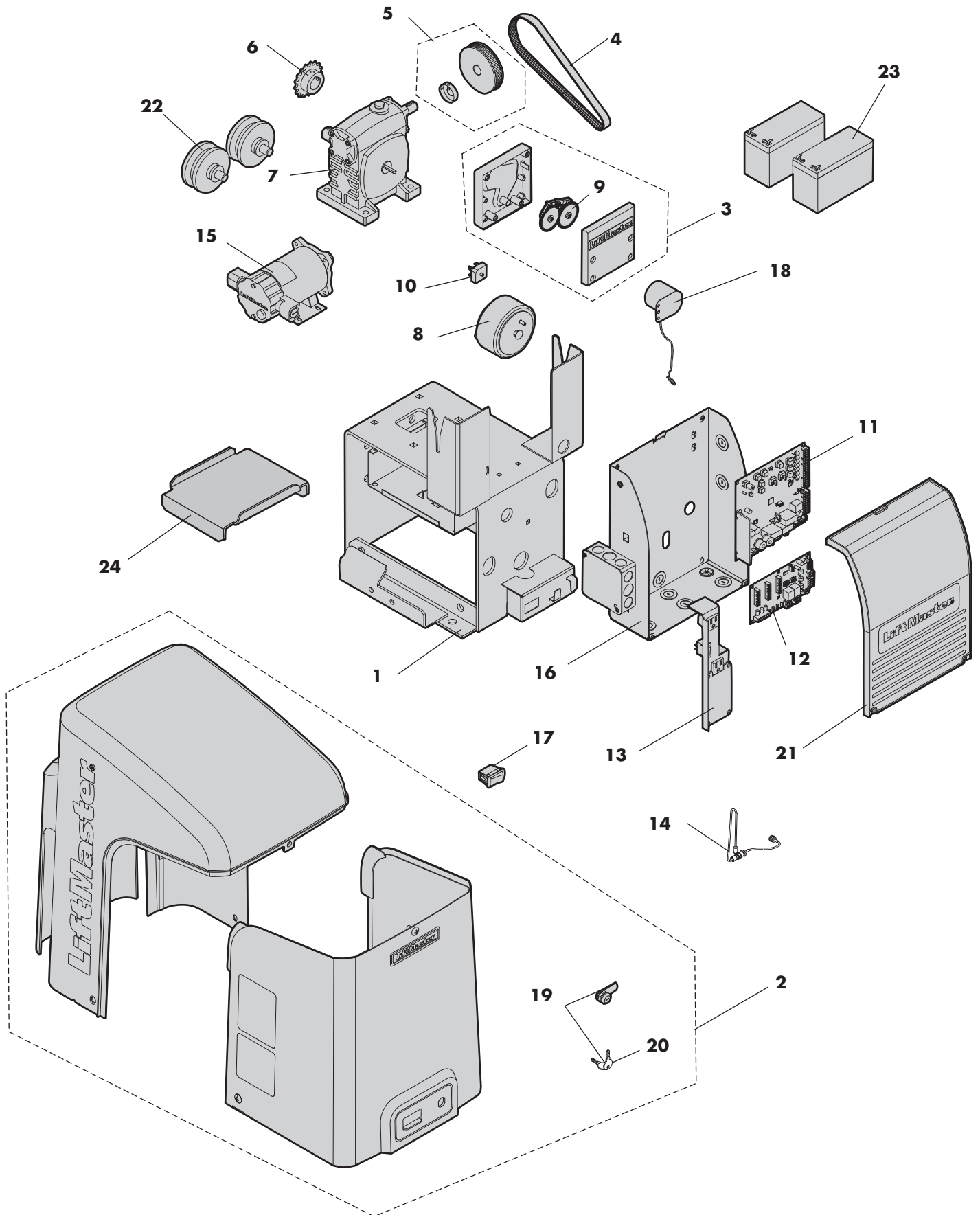



# ACCESSORIES

## ENTRAPMENT PROTECTION DEVICES

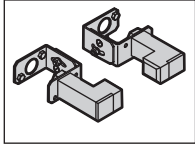

### PHOTOELECTRIC SENSORS (NON-CONTACT)

The photoelectric sensors are designed to detect an obstacle in the path of the electronic beam and stop the operator. Includes mounting brackets.  
Models AOMRON E3K-R10K4-NR (retro-reflective), RETROAB 60-2728 (retro-reflective), CPS-UN4 (through beam)

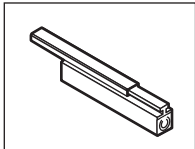

### SENSING EDGE (2-WIRE, NON-MONITORED, CONTACT)

Sensing edges can detect an obstacle upon contact and stop the operator.  
Models G65MG0204, G65MG0205, G65MGR205, and G65MGS205

### SENSING EDGE CHANNEL

Mounting channel for all MG020 type edges.  
Model G65ME120C5

## REMOTE CONTROLS

Chamberlain offers a variety of LiftMaster remote controls to satisfy your application needs. Single-button to 4-button, visor or key chain. The following remote controls are compatible with operators manufactured by Chamberlain after 1993. Contact your authorized LiftMaster dealer for additional details and options.

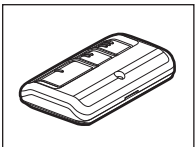

### 3-BUTTON REMOTE CONTROL

The 3-button remote control can be programmed to control the operator. Includes visor clip.  
Model 893MAX

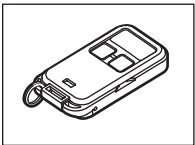

### 3-BUTTON MINI-REMOTE CONTROL

The 3-button remote control can be programmed to control the operator. Includes key ring and fastening strip.  
Model 890MAX

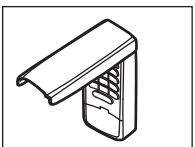

### KEYLESS ENTRY

Enables homeowner to operate gate operator from outside by entering a 4-digit code on a specially designed keypad.  
Model 877MAX

## MISCELLANEOUS

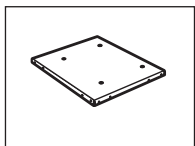

### POST-MOUNTING PLATE

For post-mounting model CSL24V commercial slide operator (also SL3000 commercial slide operator). Posts not included.  
Model MPEL



### REMOTE ANTENNA EXTENSION KIT

The remote antenna extension kit allows the antenna to be remotely installed.  
Model 86LM

# ACCESSORIES

## MISCELLANEOUS



### WIRELESS ACCESS CONTROL RECEIVER

Access control receiver for up to 450 remote controls.  
Model STAR450-315

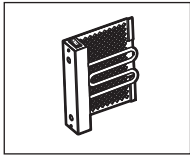

### HEATER

Keeps operator gearbox and batteries at suitable temperature when outside temperature is below 0°F for extended periods of time.  
Models GHTRKITCSL (includes heater and bracket for optimal 7AH battery location) and G6518SL (replacement heater only)

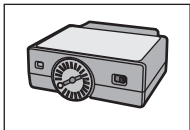

### PLUG-IN LOOP DETECTOR

Conveniently plugs into existing control board.  
Model LOOPDETLM

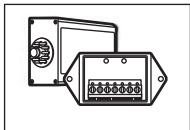

### LOOP DETECTOR

Low power loop detectors.  
Model LD7LP

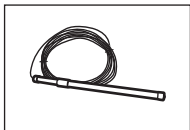

### VEHICLE SENSING PROBE

The vehicle sensing probe is buried in the ground and can detect a car as it approaches and will then open the gate.  
Model CP3

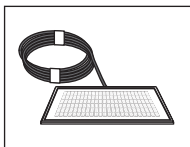

### SOLAR PANEL KIT - 10 WATT

This kit is to replace or add a solar panel to the operator application. Up to three solar panels can be connected to the operator.  
Model SOLPNL10W12V (requires 2 minimum)

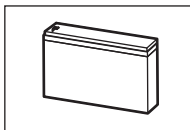

### BATTERY FOR GATE ACCESS SYSTEMS

Gate access system batteries replace or upgrade the gate operator batteries.

Model 29-NP712 (standard 7 AMP-Hour Battery or two 7 AMP-Hour battery service kit K74-30762, 12 Vdc, to replace original batteries provided with operator, reuse existing harnesses)

Model A12330SGLPK (upgrade 33 AMP-Hour Battery, 12 Vdc, 33AH wire harness is required (model K94-36596). Ideal for solar applications and extended battery backup. Two required.)

Two identical 12 Vdc batteries are required for each gate operator. Do not mix 7AH and 33AH batteries within a gate operator.

Model K75-34986-2 (battery tray for use with 33AH batteries)

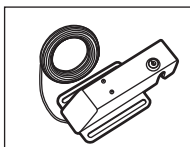

### SOLENOID GATE LOCK

The automatic gate lock is a solenoid-driven lock that automatically unlocks when the gate is open and locks when the gate is closed. Can be mounted onto a gate or post. Can be released in case of emergency.

Models GC824 (115 Vac) and GC824-12 (12/24 Vac/dc)



### MAGNETIC GATE LOCK

Outdoor magnetic lock, transformer, junction box, mounting plate and hardware. Not for use with Solar Applications. Must be powered separately.

Model MG1300

# WIRING DIAGRAM

## ⚡ WARNING

To protect against fire and electrocution:

- DISCONNECT power and battery BEFORE installing or servicing operator.

For continued protection against fire:

- Replace ONLY with fuse of same type and rating.

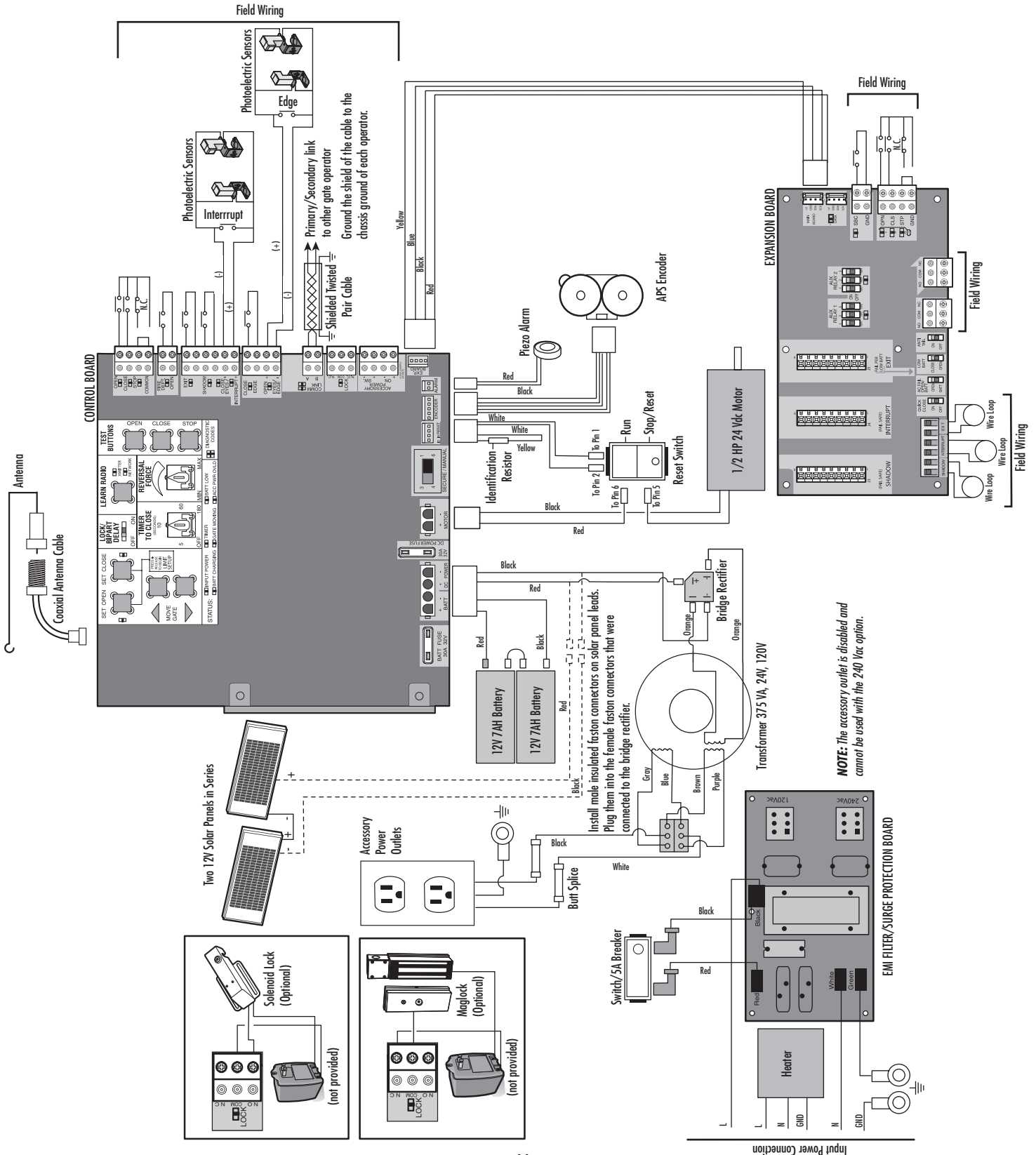

# WARRANTY

## 7 YEAR RESIDENTIAL / 5 YEAR COMMERCIAL CSL24V™ AND CSL24VH™ LIMITED WARRANTY

The Chamberlain Group, Inc. ("Seller") warrants to the first purchaser of this product, for the structure in which this product is originally installed, that it is free from defect in materials and/or workmanship for a period of 7 year residential/ 5 year commercial from the date of purchase [and that the CSL24V™ and CSL24VH™ are free from defect in materials and/or workmanship for a period of 7 year residential/ 5 year commercial from the date of purchase]. The proper operation of this product is dependent on your compliance with the instructions regarding installation, operation, maintenance and testing. Failure to comply strictly with those instructions will void this limited warranty in its entirety.

If, during the limited warranty period, this product appears to contain a defect covered by this limited warranty, call **1-800-528-2806**, toll free, before dismantling this product. Then send this product, pre-paid and insured, to our service center for warranty repair. You will be advised of shipping instructions when you call. Please include a brief description of the problem and a dated proof-of-purchase receipt with any product returned for warranty repair. Products returned to Seller for warranty repair, which upon receipt by Seller are confirmed to be defective and covered by this limited warranty, will be repaired or replaced (at Seller's sole option) at no cost to you and returned pre-paid. Defective parts will be repaired or replaced with new or factory-rebuilt parts at Seller's sole option.

**ALL IMPLIED WARRANTIES FOR THE PRODUCT, INCLUDING BUT NOT LIMITED TO ANY IMPLIED WARRANTIES OF MERCHANTABILITY AND FITNESS FOR A PARTICULAR PURPOSE, ARE LIMITED IN DURATION TO THE 7 YEAR RESIDENTIAL/ 5 YEAR COMMERCIAL LIMITED WARRANTY PERIOD SET FORTH ABOVE [EXCEPT THE IMPLIED WARRANTIES WITH RESPECT TO THE CSL24V™ AND CSL24VH™, WHICH ARE LIMITED IN DURATION TO THE 7 YEAR RESIDENTIAL/ 5 YEAR COMMERCIAL LIMITED WARRANTY PERIOD FOR THE CSL24V™ AND CSL24VH™], AND NO IMPLIED WARRANTIES WILL EXIST OR APPLY AFTER SUCH PERIOD. Some states do not allow limitations on how long an implied warranty lasts, so the above limitation may not apply to you. THIS LIMITED WARRANTY DOES NOT COVER NON-DEFECT DAMAGE, DAMAGE CAUSED BY IMPROPER INSTALLATION, OPERATION OR CARE (INCLUDING, BUT NOT LIMITED TO ABUSE, MISUSE, FAILURE TO PROVIDE REASONABLE AND NECESSARY MAINTENANCE, UNAUTHORIZED REPAIRS OR ANY ALTERATIONS TO THIS PRODUCT), LABOR CHARGES FOR REINSTALLING A REPAIRED OR REPLACED UNIT, OR REPLACEMENT OF BATTERIES.**

**THIS LIMITED WARRANTY DOES NOT COVER ANY PROBLEMS WITH, OR RELATING TO, THE GATE OR GATE HARDWARE, INCLUDING BUT NOT LIMITED TO THE GATE SPRINGS, GATE ROLLERS, GATE ALIGNMENT OR HINGES. THIS LIMITED WARRANTY ALSO DOES NOT COVER ANY PROBLEMS CAUSED BY INTERFERENCE. ANY SERVICE CALL THAT DETERMINES THE PROBLEM HAS BEEN CAUSED BY ANY OF THESE ITEMS COULD RESULT IN A FEE TO YOU.**

**UNDER NO CIRCUMSTANCES SHALL SELLER BE LIABLE FOR CONSEQUENTIAL, INCIDENTAL OR SPECIAL DAMAGES ARISING IN CONNECTION WITH USE, OR INABILITY TO USE, THIS PRODUCT. IN NO EVENT SHALL SELLER'S LIABILITY FOR BREACH OF WARRANTY, BREACH OF CONTRACT, NEGLIGENCE OR STRICT LIABILITY EXCEED THE COST OF THE PRODUCT COVERED HEREBY. NO PERSON IS AUTHORIZED TO ASSUME FOR US ANY OTHER LIABILITY IN CONNECTION WITH THE SALE OF THIS PRODUCT.**

Some states do not allow the exclusion or limitation of consequential, incidental or special damages, so the above limitation or exclusion may not apply to you. This limited warranty gives you specific legal rights, and you may also have other rights which vary from state to state.

**845 Larch Avenue  
Elmhurst, Illinois 60126-1196**