



Model "T" Drawbar Operator

PowerMaster Model "T" operators are designed for use on Standard Lift Sectional Doors.

STANDARD 2 YEAR WARRANTY.



Architectural Specifications:



**Access Alliance
Photo Beams**

Economical
Protect Openings Up to 18' Wide
Auto-Detected & Monitored by
PowerMaster Solid State Circuit



**PowerMaster
Modular Receiver**

Easy Installation –
Plugs into Control Board
Standard Three Channel - Open/Close/Stop
Single Button Control Available
FC Antenna

Complete Selection of Commercial Transmitters Available



**OSE
OPTICAL SENSING EDGE**

Auto-Detected & Monitored by PowerMaster Solid State Circuit Functions when astragal is bent or has slight damage
Sized to Door in the field
Quick Installation
Infrared Technology

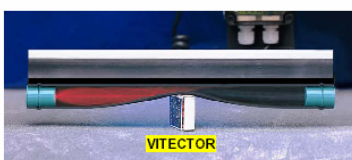

VITECTOR



All types of Access Controls available. Call for pricing.

Supply PowerMaster Model "T" Drawbar Operator(s) RATED ___ HP, ___ VOLTS, ___ PHASE, for use on Standard Lift Sectional Doors. Primary reduction shall be by heavy duty V-Belt Drive. Secondary reduction shall be a chain and sprocket arrangement. Motor shall be continuous duty industrial type protected from overload by a current sensing or thermal type overload device.

Motor shall be of the high starting torque, continuous duty industrial type, protected from overload by a current sensing or thermal type overload device. Motor controller shall be a heavy duty, full voltage, across the line, magnetic reversing contactor that is mechanically and electrically interlocked. Electrical components shall be installed in a NEMA 1 enclosure integral to the operator. A transformer shall be provided to reduce control voltage to 24 VAC. Separate terminal strips shall be provided for connection of power supply line and all control devices. Operator shall be wired for an open/close/stop control station. Control circuit shall provide instant reverse motor wiring on 1Ø operators. Positive chain driven, rotary type limit switches shall be provided to limit full open and close travel of door. Limit switch adjustment shall not be affected by removal of motor or by manual operation of door.

An adjustable torque limiting clutch shall be provided to prevent overloading of the operator. A spring set solenoid released brake shall be supplied on ¾ & 1HP units. A disconnect arm for manual operation of the door shall be provided in case of power failure. The final reduction and drive shall be heavy duty roller chain and sprockets. The drive shaft shall be supported by oilite bearings and be a minimum of ¾ In diameter

**PowerMaster Garage Door Openers
Proudly Assembled in the USA**

Electrical Specifications:

- High Starting Torque Motor with Full Overload Protection
- Solid State Circuitry with Power and Program Feedback LED's
- On Board Open/Close/Stop buttons for service and adjustments
- Terminals labeled and grouped by function
- Auto-Detect monitored photo beam for simplified installation
- Selectable Operating modes B2, C2, D1, E2, T, TS
- Field adjustable built in functions including: timer to close, mid-stop, delay on reverse, lock bar sensing, maximum run time, etc.

Mechanical Specifications:

- For Use on Sectional Doors
- Heavy Duty V-Belt and Chain Reduction, Mechanically Self Locking
- Heavy Duty #65 Roller Chain Included
- Adjustable Torque Limiting Clutch
- Positive Chain Driven Rotary Limit Switches
- Drawbar Disconnect (For Manual Operation in case of power failure)
- Baked on Grey Powder Coat finish

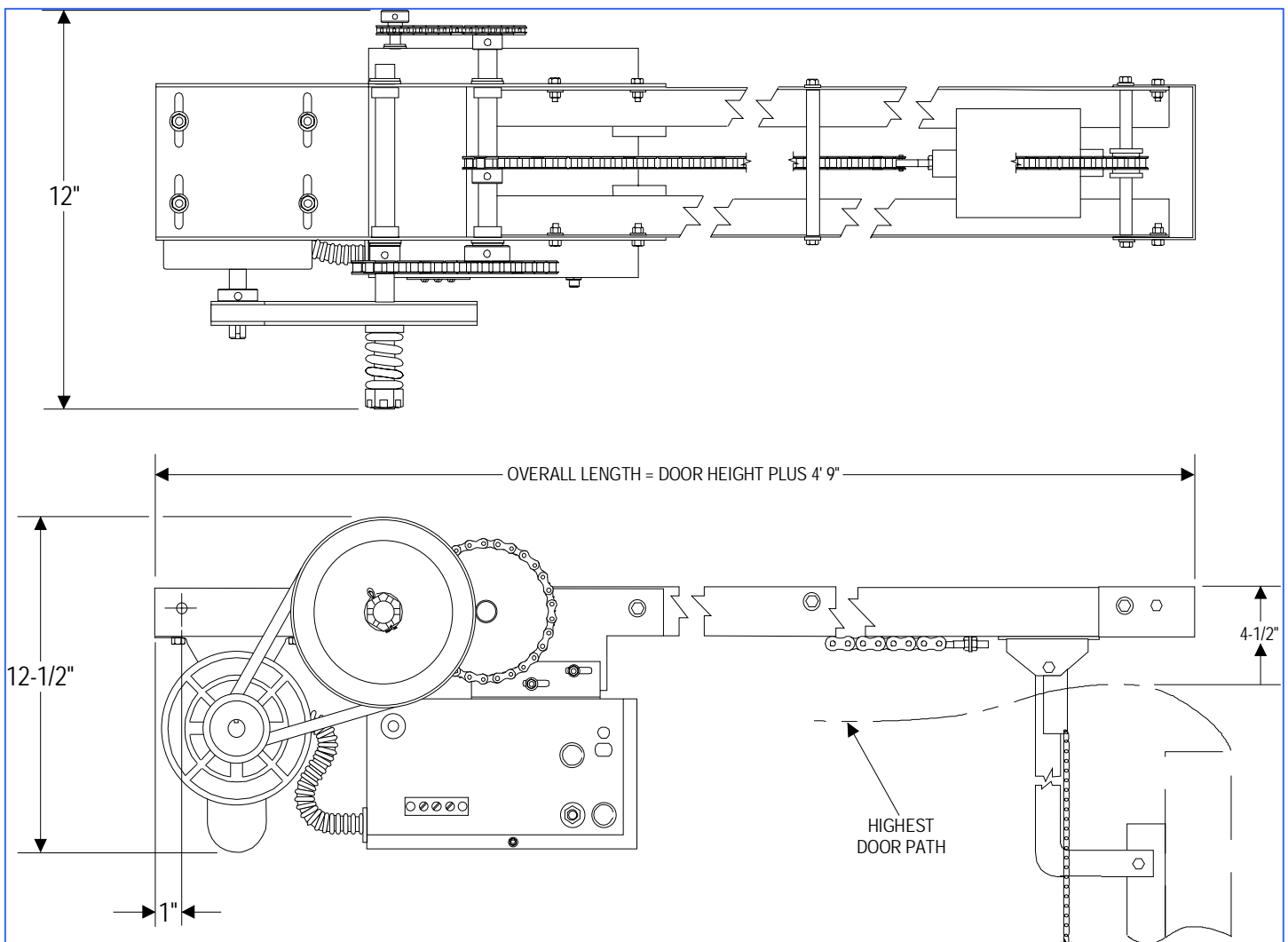

AUTHORIZED DISTRIBUTOR: